

SIEMENS

SINAMICS/SIMOTICS

SINAMICS V90, SIMOTICS S-1FL6

Operating Instructions

PROFINET (PN) interface

Preface

Fundamental safety instructions

1

General information

2

Mounting

3

Connecting

4

Commissioning

5

Basic operator panel (BOP)

6

Control functions

7

PROFINET communication

8

Safety integrated function

9

Tuning

10

Parameters

11

Diagnostics

12



Appendix

A

Legal information

Warning notice system

This manual contains notices you have to observe in order to ensure your personal safety, as well as to prevent damage to property. The notices referring to your personal safety are highlighted in the manual by a safety alert symbol, notices referring only to property damage have no safety alert symbol. These notices shown below are graded according to the degree of danger.

 DANGER
indicates that death or severe personal injury will result if proper precautions are not taken.
 WARNING
indicates that death or severe personal injury may result if proper precautions are not taken.
 CAUTION
indicates that minor personal injury can result if proper precautions are not taken.
NOTICE
indicates that property damage can result if proper precautions are not taken.

If more than one degree of danger is present, the warning notice representing the highest degree of danger will be used. A notice warning of injury to persons with a safety alert symbol may also include a warning relating to property damage.

Qualified Personnel

The product/system described in this documentation may be operated only by **personnel qualified** for the specific task in accordance with the relevant documentation, in particular its warning notices and safety instructions. Qualified personnel are those who, based on their training and experience, are capable of identifying risks and avoiding potential hazards when working with these products/systems.

Proper use of Siemens products

Note the following:

 WARNING
Siemens products may only be used for the applications described in the catalog and in the relevant technical documentation. If products and components from other manufacturers are used, these must be recommended or approved by Siemens. Proper transport, storage, installation, assembly, commissioning, operation and maintenance are required to ensure that the products operate safely and without any problems. The permissible ambient conditions must be complied with. The information in the relevant documentation must be observed.

Trademarks

All names identified by ® are registered trademarks of Siemens AG. The remaining trademarks in this publication may be trademarks whose use by third parties for their own purposes could violate the rights of the owner.

Disclaimer of Liability

We have reviewed the contents of this publication to ensure consistency with the hardware and software described. Since variance cannot be precluded entirely, we cannot guarantee full consistency. However, the information in this publication is reviewed regularly and any necessary corrections are included in subsequent editions.

Preface

Documentation components

Document	Content
Operating Instructions	(this manual)
Getting Started	Describes how to install, connect, operate, and perform basic commissioning of the SINAMICS V90 PN servo system.
SIMOTICS S-1FL6 Servo Motors Installation Guide	Describes how to install the SMOTICS S-1FL6 servo motor and relevant safety notices.
SINAMICS V90 Servo Drives Information Guide	Introduces the basic information of the documents and describes how to find all the SINAMICS V90 documents from the website.
SINAMICS V90 V-ASSISTANT Online Help	Describes how to perform fast commissioning and diagnostics for the SINAMICS V90 drives via the SINAMICS V-ASSISTANT engineering tool.

Target group

This manual provides information about the SINAMICS V90 PN servo system for planners, operators, mechanical engineers, electrical engineers, commissioning engineers, and service engineers.

Technical support

Country	Hotline
China	+86 400 810 4288
Germany	+49 911 895 7222
Italy	+39 (02) 24362000
India	+91 22 2760 0150
Turkey	+90 (216) 4440747
Further service contact information: Support contacts (https://support.industry.siemens.com/cs/ww/en/)	

Product maintenance

The components are subject to continuous further development within the scope of product maintenance (improvements to robustness, discontinuations of components, etc).

These further developments are "spare parts-compatible" and do not change the article number.

In the scope of such spare parts-compatible further developments, connector positions are sometimes changed slightly. This does not cause any problems with proper use of the

components. Please take this fact into consideration in special installation situations (e.g. allow sufficient clearance for the cable length).

Use of third-party products

This document contains recommendations relating to third-party products. Siemens accepts the fundamental suitability of these third-party products.

You can use equivalent products from other manufacturers.

Siemens does not accept any warranty for the properties of third-party products.

Environmental protection



Waste electrical products cannot be disposed of with household waste. Please recycle where facilities exist. Check with your local authority or retailer for recycling advice.

Table of contents

	Preface	3
1	Fundamental safety instructions	11
1.1	General safety instructions	11
1.2	Equipment damage due to electric fields or electrostatic discharge	18
1.3	Warranty and liability for application examples	18
1.4	Industrial security	19
1.5	Residual risks of power drive systems.....	20
2	General information	23
2.1	Deliverables	23
2.1.1	Drive components	23
2.1.2	Motor components	28
2.2	Device combination.....	32
2.3	Product overview	35
2.4	Accessories.....	39
2.4.1	MOTION-CONNECT 300 cables and connectors	39
2.4.2	PROFINET cable and connector	41
2.4.3	Connectors used on the drive front panel.....	41
2.4.4	External 24 VDC power supply	43
2.4.5	Fuse/Type-E combination motor controller.....	43
2.4.6	Braking resistor	45
2.4.7	Filter	46
2.4.8	Micro SD card/SD card	52
2.4.9	Replacement fans	52
2.5	Function list.....	53
2.6	Technical data.....	54
2.6.1	Technical data - servo drives.....	54
2.6.1.1	SINAMICS V90 PN 200 V variant.....	54
2.6.1.2	SINAMICS V90 PN 400 V variant.....	57
2.6.2	Technical data - servo motors	60
2.6.2.1	1FL6 servo motor - low inertia	60
2.6.2.2	1FL6 servo motor - high inertia	64
2.6.2.3	Power derating.....	68
2.6.3	Technical data - cables	68
2.6.4	Address of CE-authorized manufacturer	70
3	Mounting.....	71
3.1	Mounting the drive	71
3.1.1	Mounting orientation and clearance.....	72
3.1.2	Drill patterns and outline dimensions.....	73
3.1.3	Mounting the drive	77

3.2	Mounting the motor	78
3.2.1	Mounting orientation and dimensions	78
3.2.2	Mounting the motor	87
3.2.3	Motor heating conditions	89
4	Connecting	91
4.1	System connection.....	91
4.2	Main circuit wiring.....	97
4.2.1	Line supply - L1, L2, L3.....	97
4.2.2	Motor power - U, V, W	99
4.3	Control/status interface - X8	102
4.3.1	Digital inputs/outputs (DIs/Dos)	102
4.3.1.1	DIs	103
4.3.1.2	DOs	104
4.3.2	Standard application wiring (factory setting)	106
4.3.3	Connection example with PLCs	108
4.3.3.1	SIMATIC S7-1200	108
4.3.3.2	SIMATIC S7-1500	109
4.4	24 V power supply/STO	110
4.5	Encoder interface - X9	112
4.6	External braking resistor - DCP, R1.....	116
4.7	Motor holding brake	116
4.8	PROFINET interface - X150	123
5	Commissioning	125
5.1	General commissioning information.....	125
5.2	Commissioning in JOG mode	127
5.3	Commissioning in basic positioner control mode (EPOS)	129
5.4	Commissioning in speed control mode (S)	130
6	Basic operator panel (BOP)	131
6.1	BOP overview	131
6.1.1	LED status indicators	132
6.1.2	BOP display	133
6.1.3	Control buttons.....	136
6.2	Parameter structure	137
6.3	Actual status display	138
6.4	Basic operations.....	139
6.4.1	Editing parameters.....	140
6.4.2	Viewing parameters	142
6.4.3	Searching parameters in "P ALL" menu	142
6.5	Auxiliary functions	143
6.5.1	JOG.....	144
6.5.2	Saving parameters (RAM to ROM)	145
6.5.3	Setting parameters to default.....	146

6.5.4	Transferring data (drive to SD)	146
6.5.5	Transferring data (SD to drive)	147
6.5.6	Updating firmware	148
6.5.7	Adjusting an absolute encoder	149
7	Control functions	151
7.1	General functions	151
7.1.1	Motor direction of rotation	151
7.1.2	Stopping method at servo OFF	152
7.1.3	Travel to fixed stop	153
7.1.4	Position tracking	158
7.2	Basic positioner (EPOS)	162
7.2.1	Setting the mechanical system	162
7.2.2	Configuring the linear/modular axis	163
7.2.3	Backlash compensation	164
7.2.4	Over-travel	165
7.2.5	Software position limit	166
7.2.6	Speed limit	167
7.2.7	Torque limit	167
7.2.8	Referencing	167
7.2.9	Traversing blocks	172
7.2.10	Direct setpoint input (MDI)	178
7.2.11	EJOG	181
7.3	Speed control (S)	183
7.3.1	Speed limit	183
7.3.2	Torque limit	184
7.3.3	Ramp-function generator	186
8	PROFINET communication	189
8.1	Supported telegrams	189
8.2	I/O data signals	191
8.3	Control word definition	193
8.3.1	STW1 control word (for telegrams 1, 2, 3, 5)	193
8.3.2	STW2 control word (for telegrams 2, 3, 5)	194
8.3.3	STW1 control word (for telegrams 102, 105)	195
8.3.4	STW2 control word (for telegrams 102, 105)	196
8.3.5	STW1 control word (for telegrams 7, 9, 110, 111)	196
8.3.6	STW2 control word (for telegrams 9, 110, 111)	197
8.3.7	G1_STW encoder 1 control word	198
8.3.8	SATZANW control word	198
8.3.9	MDI_MOD control word	199
8.3.10	POS_STW control word	200
8.3.11	POS_STW1 positioning control word	200
8.3.12	POS_STW2 positioning control word	201
8.4	Status word definition	202
8.4.1	ZSW1 status word (for telegrams 1, 2, 3, 5)	202
8.4.2	ZSW2 status word (for telegrams 2, 3, 5)	202
8.4.3	ZSW1 status word (for telegrams 102, 105)	203
8.4.4	ZSW2 status word (for telegrams 102, 105)	203
8.4.5	ZSW1 status word (for telegrams 7, 9, 110, 111)	204

8.4.6	ZSW2 status word (for telegrams 9, 110, 111)	204
8.4.7	G1_ZSW encoder 1 status word	205
8.4.8	MELDW status word	206
8.4.9	POS_ZSW1 positioning status word	206
8.4.10	POS_ZSW2 positioning status word	207
9	Safety integrated function.....	209
9.1	Standards and regulations	209
9.1.1	General information	209
9.1.1.1	Aims	209
9.1.1.2	Functional safety	210
9.1.2	Safety of machinery in Europe	210
9.1.2.1	Machinery Directive	210
9.1.2.2	Harmonized European Standards.....	211
9.1.2.3	Standards for implementing safety-related controllers	212
9.1.2.4	DIN EN ISO 13849-1	213
9.1.2.5	EN 62061	214
9.1.2.6	Series of standards EN 61508 (VDE 0803)	216
9.1.2.7	Risk analysis/assessment.....	216
9.1.2.8	Risk reduction	218
9.1.2.9	Residual risk.....	218
9.1.3	Machine safety in the USA.....	218
9.1.3.1	Minimum requirements of the OSHA	218
9.1.3.2	NRTL listing.....	219
9.1.3.3	NFPA 79.....	219
9.1.3.4	ANSI B11	220
9.1.4	Machine safety in Japan	221
9.1.5	Equipment regulations	221
9.2	General information about SINAMICS Safety Integrated	222
9.3	System features	222
9.3.1	STO functional safety data.....	222
9.3.2	Certification	222
9.3.3	Safety instructions.....	223
9.3.4	Probability of failure of the safety function	224
9.3.5	Response time	225
9.3.6	Residual risk.....	225
9.4	Safety Integrated basic function.....	225
9.4.1	Safe Torque Off (STO).....	225
9.4.2	Forced dormant error detection	228
10	Tuning	229
10.1	Controller overview	229
10.2	Tuning mode	231
10.3	One-button auto tuning	232
10.4	Real-time auto tuning.....	237
10.5	Manual tuning.....	240
10.6	Resonance suppression	241
10.7	Low frequency vibration suppression.....	244

11	Parameters	245
11.1	Overview	245
11.2	Parameter list.....	247
12	Diagnostics	283
12.1	Overview	283
12.2	List of faults and alarms	287
A	Appendix	313
A.1	Assembly of cable terminals on the drive side	313
A.2	Assembly of cable connectors on the motor side	316
A.3	Motor selection.....	323
A.3.1	Selection procedure	323
A.3.2	Parameter description.....	324
A.3.3	Selection examples.....	327
A.4	Replacing fans	328
	Index	329

Fundamental safety instructions

1.1 General safety instructions



! WARNING

Electric shock and danger to life due to other energy sources

Touching live components can result in death or severe injury.

- Only work on electrical devices when you are qualified for this job.
- Always observe the country-specific safety rules.

Generally, the following six steps apply when establishing safety:

1. Prepare for disconnection. Notify all those who will be affected by the procedure.
2. Isolate the drive system from the power supply and take measures to prevent it being switched back on again.
3. Wait until the discharge time specified on the warning labels has elapsed.
4. Check that there is no voltage between any of the power connections, and between any of the power connections and the protective conductor connection.
5. Check whether the existing auxiliary supply circuits are de-energized.
6. Ensure that the motors cannot move.
7. Identify all other dangerous energy sources, e.g. compressed air, hydraulic systems, or water. Switch the energy sources to a safe state.
8. Check that the correct drive system is completely locked.

After you have completed the work, restore the operational readiness in the inverse sequence.



! WARNING

Risk of electric shock and fire from supply networks with an excessively high impedance

Excessively low short-circuit currents can lead to the protective devices not tripping or tripping too late, and thus causing electric shock or a fire.

- In the case of a conductor-conductor or conductor-ground short-circuit, ensure that the short-circuit current at the point where the inverter is connected to the line supply at least meets the minimum requirements for the response of the protective device used.
- You must use an additional residual-current device (RCD) if a conductor-ground short circuit does not reach the short-circuit current required for the protective device to respond. The required short-circuit current can be too low, especially for TT supply systems.



! WARNING

Risk of electric shock and fire from supply networks with an excessively low impedance

Excessively high short-circuit currents can lead to the protective devices not being able to interrupt these short-circuit currents and being destroyed, and thus causing electric shock or a fire.

- Ensure that the prospective short-circuit current at the line terminal of the inverter does not exceed the breaking capacity (SCCR or I_{cc}) of the protective device used.



! WARNING

Electric shock if there is no ground connection

For missing or incorrectly implemented protective conductor connection for devices with protection class I, high voltages can be present at open, exposed parts, which when touched, can result in death or severe injury.

- Ground the device in compliance with the applicable regulations.



! WARNING

Electric shock due to connection to an unsuitable power supply

When equipment is connected to an unsuitable power supply, exposed components may carry a hazardous voltage that might result in serious injury or death.

- Only use power supplies that provide SELV (Safety Extra Low Voltage) or PELV- (Protective Extra Low Voltage) output voltages for all connections and terminals of the electronics modules.



! WARNING

Electric shock due to damaged motors or devices

Improper handling of motors or devices can damage them.

Hazardous voltages can be present at the enclosure or at exposed components on damaged motors or devices.

- Ensure compliance with the limit values specified in the technical data during transport, storage and operation.
- Do not use any damaged motors or devices.



! WARNING

Electric shock due to unconnected cable shields

Hazardous touch voltages can occur through capacitive cross-coupling due to unconnected cable shields.

- As a minimum, connect cable shields and the cores of cables that are not used at one end at the grounded housing potential.



! WARNING

Arcing when a plug connection is opened during operation

Opening a plug connection when a system is operation can result in arcing that may cause serious injury or death.

- Only open plug connections when the equipment is in a voltage-free state, unless it has been explicitly stated that they can be opened in operation.



! WARNING

Electric shock due to residual charges in power components

Because of the capacitors, a hazardous voltage is present for up to 5 minutes after the power supply has been switched off. Contact with live parts can result in death or serious injury.

- Wait for 5 minutes before you check that the unit really is in a no-voltage condition and start work.

NOTICE

Property damage due to loose power connections

Insufficient tightening torques or vibration can result in loose power connections. This can result in damage due to fire, device defects or malfunctions.

- Tighten all power connections to the prescribed torque.
- Check all power connections at regular intervals, particularly after equipment has been transported.

 **WARNING**

Spread of fire from built-in devices

In the event of fire outbreak, the enclosures of built-in devices cannot prevent the escape of fire and smoke. This can result in serious personal injury or property damage.

- Install built-in units in a suitable metal cabinet in such a way that personnel are protected against fire and smoke, or take other appropriate measures to protect personnel.
- Ensure that smoke can only escape via controlled and monitored paths.

 **WARNING**

Active implant malfunctions due to electromagnetic fields

Inverters generate electromagnetic fields (EMF) in operation. People with active implants in the immediate vicinity of this equipment are at particular risk.

- As the operator of an EMF-emitting installation, assess the individual risks of persons with active implants. The following clearances are usually adequate:
 - No clearance to closed control cabinets and shielded MOTION-CONNECT supply cables
 - Forearm length (approx. 35 cm clearance) to distributed drive systems and open control cabinets

 **WARNING**

Active implant malfunctions due to permanent-magnet fields

Even when switched off, electric motors with permanent magnets represent a potential risk for persons with heart pacemakers or implants if they are close to converters/motors.

- If you have a heart pacemaker or implant, maintain a minimum distance of 2 m.
- When transporting or storing permanent-magnet motors always use the original packing materials with the warning labels attached.
- Clearly mark the storage locations with the appropriate warning labels.
- IATA regulations must be observed when transported by air.

 **WARNING**

Unexpected movement of machines caused by radio devices or mobile phones

When radio devices or mobile phones with a transmission power > 1 W are used in the immediate vicinity of components, they may cause the equipment to malfunction. Malfunctions may impair the functional safety of machines and can therefore put people in danger or lead to property damage.

- If you come closer than around 2 m to such components, switch off any radios or mobile phones.
- Use the "SIEMENS Industry Online Support app" only on equipment that has already been switched off.

NOTICE**Damage to motor insulation due to excessive voltages**

When operated on systems with grounded line conductor or in the event of a ground fault in the IT system, the motor insulation can be damaged by the higher voltage to ground. If you use motors that have insulation that is not designed for operation with grounded line conductors, you must perform the following measures:

- IT system: Use a ground fault monitor and eliminate the fault as quickly as possible.
- TN or TT systems with grounded line conductor: Use an isolating transformer on the line side.

 **WARNING****Fire due to inadequate ventilation clearances**

Inadequate ventilation clearances can cause overheating of components with subsequent fire and smoke. This can cause severe injury or even death. This can also result in increased downtime and reduced service lives for devices/systems.

- Ensure compliance with the specified minimum clearance as ventilation clearance for the respective component.

 **WARNING****Unrecognized dangers due to missing or illegible warning labels**

Dangers might not be recognized if warning labels are missing or illegible. Unrecognized dangers may cause accidents resulting in serious injury or death.

- Check that the warning labels are complete based on the documentation.
- Attach any missing warning labels to the components, where necessary in the national language.
- Replace illegible warning labels.

NOTICE**Device damage caused by incorrect voltage/insulation tests**

Incorrect voltage/insulation tests can damage the device.

- Before carrying out a voltage/insulation check of the system/machine, disconnect the devices as all converters and motors have been subject to a high voltage test by the manufacturer, and therefore it is not necessary to perform an additional test within the system/machine.

 **WARNING**

Unexpected movement of machines caused by inactive safety functions

Inactive or non-adapted safety functions can trigger unexpected machine movements that may result in serious injury or death.

- Observe the information in the appropriate product documentation before commissioning.
- Carry out a safety inspection for functions relevant to safety on the entire system, including all safety-related components.
- Ensure that the safety functions used in your drives and automation tasks are adjusted and activated through appropriate parameterizing.
- Perform a function test.
- Only put your plant into live operation once you have guaranteed that the functions relevant to safety are running correctly.

Note

Important safety notices for Safety Integrated functions

If you want to use Safety Integrated functions, you must observe the safety notices in the Safety Integrated manuals.

 **WARNING**

Malfunctions of the machine as a result of incorrect or changed parameter settings

As a result of incorrect or changed parameterization, machines can malfunction, which in turn can lead to injuries or death.

- Protect the parameterization (parameter assignments) against unauthorized access.
- Handle possible malfunctions by taking suitable measures, e.g. emergency stop or emergency off.

 **WARNING**

Injury caused by moving or ejected parts

Contact with moving motor parts or drive output elements and the ejection of loose motor parts (e.g. feather keys) out of the motor enclosure can result in severe injury or death.

- Remove any loose parts or secure them so that they cannot be flung out.
- Do not touch any moving parts.
- Safeguard all moving parts using the appropriate safety guards.

 **WARNING****Fire due to inadequate cooling**

Inadequate cooling can cause the motor to overheat, resulting in death or severe injury as a result of smoke and fire. This can also result in increased failures and reduced service lives of motors.

- Comply with the specified cooling requirements for the motor.

 **WARNING****Fire due to incorrect operation of the motor**

When incorrectly operated and in the case of a fault, the motor can overheat resulting in fire and smoke. This can result in severe injury or death. Further, excessively high temperatures destroy motor components and result in increased failures as well as shorter service lives of motors.

- Operate the motor according to the relevant specifications.
- Only operate the motors in conjunction with effective temperature monitoring.
- Immediately switch off the motor if excessively high temperatures occur.

 **CAUTION****Burn injuries caused by hot surfaces**

In operation, the motor can reach high temperatures, which can cause burns if touched.

- Mount the motor so that it is not accessible in operation.

Measures when maintenance is required:

- Allow the motor to cool down before starting any work.
- Use the appropriate personnel protection equipment, e.g. gloves.

1.2 Equipment damage due to electric fields or electrostatic discharge

Electrostatic sensitive devices (ESD) are individual components, integrated circuits, modules or devices that may be damaged by either electric fields or electrostatic discharge.



NOTICE

Equipment damage due to electric fields or electrostatic discharge

Electric fields or electrostatic discharge can cause malfunctions through damaged individual components, integrated circuits, modules or devices.

- Only pack, store, transport and send electronic components, modules or devices in their original packaging or in other suitable materials, e.g. conductive foam rubber or aluminum foil.
- Only touch components, modules and devices when you are grounded by one of the following methods:
 - Wearing an ESD wrist strap
 - Wearing ESD shoes or ESD grounding straps in ESD areas with conductive flooring
- Only place electronic components, modules or devices on conductive surfaces (table with ESD surface, conductive ESD foam, ESD packaging, ESD transport container).

1.3 Warranty and liability for application examples

Application examples are not binding and do not claim to be complete regarding configuration, equipment or any eventuality which may arise. Application examples do not represent specific customer solutions, but are only intended to provide support for typical tasks.

As the user you yourself are responsible for ensuring that the products described are operated correctly. Application examples do not relieve you of your responsibility for safe handling when using, installing, operating and maintaining the equipment.

1.4 Industrial security

Note

Industrial security

Siemens provides products and solutions with industrial security functions that support the secure operation of plants, systems, machines and networks.

In order to protect plants, systems, machines and networks against cyber threats, it is necessary to implement – and continuously maintain – a holistic, state-of-the-art industrial security concept. Siemens' products and solutions constitute one element of such a concept.

Customers are responsible for preventing unauthorized access to their plants, systems, machines and networks. Such systems, machines and components should only be connected to an enterprise network or the Internet if and to the extent such a connection is necessary and only when appropriate security measures (e.g. firewalls and/or network segmentation) are in place.

For additional information on industrial security measures that may be implemented, please visit:

Industrial security (<http://www.siemens.com/industrialsecurity>)

Siemens' products and solutions undergo continuous development to make them more secure. Siemens strongly recommends that product updates are applied as soon as they are available and that the latest product versions are used. Use of product versions that are no longer supported, and failure to apply the latest updates may increase customer's exposure to cyber threats.

To stay informed about product updates, subscribe to the Siemens Industrial Security RSS Feed at:

Industrial security (<http://www.siemens.com/industrialsecurity>)

Further information is provided on the Internet:

Industrial Security Configuration Manual
(<https://support.industry.siemens.com/cs/ww/en/view/108862708>)

 **WARNING**

Unsafe operating states resulting from software manipulation

Software manipulations (e.g. viruses, trojans, malware or worms) can cause unsafe operating states in your system that may lead to death, serious injury, and property damage.

- Keep the software up to date.
- Incorporate the automation and drive components into a holistic, state-of-the-art industrial security concept for the installation or machine.
- Make sure that you include all installed products into the holistic industrial security concept.
- Protect files stored on exchangeable storage media from malicious software by with suitable protection measures, e.g. virus scanners.
- Protect the drive against unauthorized changes by activating the "know-how protection" drive function.

1.5 Residual risks of power drive systems

When assessing the machine- or system-related risk in accordance with the respective local regulations (e.g., EC Machinery Directive), the machine manufacturer or system installer must take into account the following residual risks emanating from the control and drive components of a drive system:

1. Unintentional movements of driven machine or system components during commissioning, operation, maintenance, and repairs caused by, for example,
 - Hardware and/or software errors in the sensors, control system, actuators, and cables and connections
 - Response times of the control system and of the drive
 - Operation and/or environmental conditions outside the specification
 - Condensation/conductive contamination
 - Parameterization, programming, cabling, and installation errors
 - Use of wireless devices/mobile phones in the immediate vicinity of electronic components
 - External influences/damage
 - X-ray, ionizing radiation and cosmic radiation
2. Unusually high temperatures, including open flames, as well as emissions of light, noise, particles, gases, etc., can occur inside and outside the components under fault conditions caused by, for example:
 - Component failure
 - Software errors

- Operation and/or environmental conditions outside the specification
 - External influences/damage
3. Hazardous shock voltages caused by, for example:
- Component failure
 - Influence during electrostatic charging
 - Induction of voltages in moving motors
 - Operation and/or environmental conditions outside the specification
 - Condensation/conductive contamination
 - External influences/damage
4. Electrical, magnetic and electromagnetic fields generated in operation that can pose a risk to people with a pacemaker, implants or metal replacement joints, etc., if they are too close
5. Release of environmental pollutants or emissions as a result of improper operation of the system and/or failure to dispose of components safely and correctly
6. Influence of network-connected communication systems, e.g. ripple-control transmitters or data communication via the network

For more information about the residual risks of the drive system components, see the relevant sections in the technical user documentation.

General information

The SINAMICS V90 drives with the PROFINET interface (referred to as SINAMICS V90 PN) are available in two variants, 400 V variant and 200 V variant.





The 200 V variant is available in four frame sizes: FSA, FSB, FSC, and FSD. Frame sizes A, B, and C are used on the single phase or three phase power network while frame size D is used on the three phase power network only.

The 400 V variant is available in four frame sizes: FSAA, FSA, FSB, and FSC. All the frame sizes are used on three phase power network only.



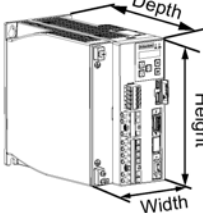



2.1 Deliverables

2.1.1 Drive components

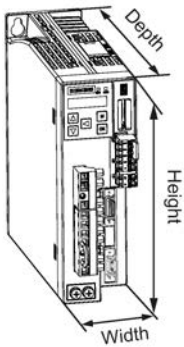
Components in the SINAMICS V90 PN 200 V variant drive package

Component	Illustration	Rated power (kW)	Outline dimension (Width x Height x Depth, mm)	Frame size	Article number
SINAMICS V90 PN, single/three-phase, 200 V		0.1/0.2	45 x 170 x 170	FSA	6SL3210-5FB10-1UF1
		0.4	55 x 170 x 170	FSB	6SL3210-5FB10-4UF1
		0.75	80 x 170 x 195	FSC	6SL3210-5FB10-8UF0
SINAMICS V90 PN, three-phase, 200 V		1.0/1.5/2.0	95 x 170 x 195	FSD	6SL3210-5FB11-0UF1
					6SL3210-5FB11-5UF0
					6SL3210-5FB12-0UF0
Connectors		For FSA and FSB			
		For FSC and FSD			
Shielding plate		For FSA and FSB			
		For FSC and FSD			
User documentation	Information Guide	English-Chinese bilingual version			

Components in the SINAMICS V90 PN 400 V variant drive package

Component	Illustration	Rated power (kW)	Outline dimension (Width x Height x Depth, mm)	Frame size	Article number
SINAMICS V90 PN, three-phase, 400 V		0.4	60 x 180 x 200	FSAA	6SL3210-5FE10-4UF0
		0.75/1.0	80 x 180 x 200	FSA	6SL3210-5FE10-8UF0 6SL3210-5FE11-0UF0
		1.5/2.0	100 x 180 x 220	FSB	6SL3210-5FE11-5UF0 6SL3210-5FE12-0UF0
		3.5/5.0/7.0	140 x 260 x 240	FSC	6SL3210-5FE13-5UF0
					6SL3210-5FE15-0UF0
					6SL3210-5FE17-0UF0
Connectors		For FSAA			
		For FSA			
		For FSB and FSC			
Shielding plate		For FSAA and FSA			
		For FSB and FSC			
User documentation	Information Guide	English-Chinese bilingual version			

Drive rating plate (example)

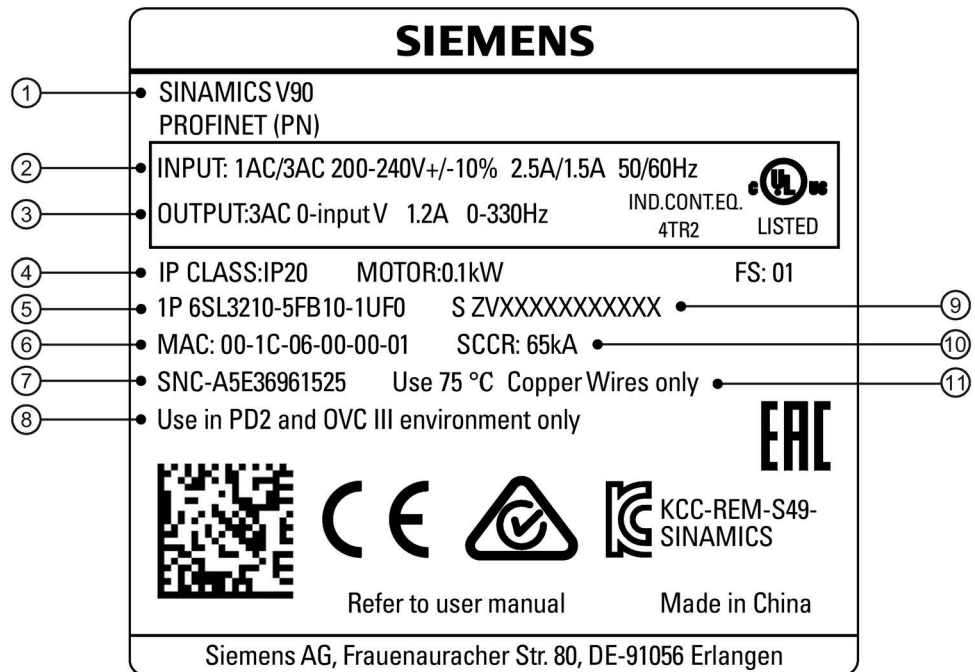

- | | |
|---------------------|---|
| ① Drive name | ⑦ Part number |
| ② Power input | ⑧ Pollution degree and overvoltage criteria |
| ③ Power output | ⑨ Product serial number |
| ④ Rated motor power | ⑩ Rated short-circuit current |
| ⑤ Article number | ⑪ Copper wire |
| ⑥ MAC address | |

Article number explanation (example)

6 S L 3 2 1 0 - 5 F B 1 0 - 1 U F 0

Supply voltage

Symbol	Supply voltage
B	1/3 phase 200~240 VAC
E	3 phase 380~480 VAC

Drive version

Symbol	Drive version
A	V90 Pulse train (PTI) version
F	V90 PROFINET (PN) version

Supported max motor power

Symbol	Supported max motor power	Supply voltage
10-1	0.1 kW	200 V
10-2	0.2 kW	200 V
10-4	0.4 kW	200 V
	0.4 kW	400 V
10-8	0.75 kW	200 V
	0.75 kW	400 V
11-0	1.0 kW	200 V
	1.0 kW	400 V
11-5	1.5 kW	200 V
	1.75 kW	400 V
12-0	2.0 kW	200 V
	2.5 kW	400 V
13-5	3.5 kW	400 V
15-0	5.0 kW	400 V
17-0	7.0 kW	400 V

Serial number explanation (example)

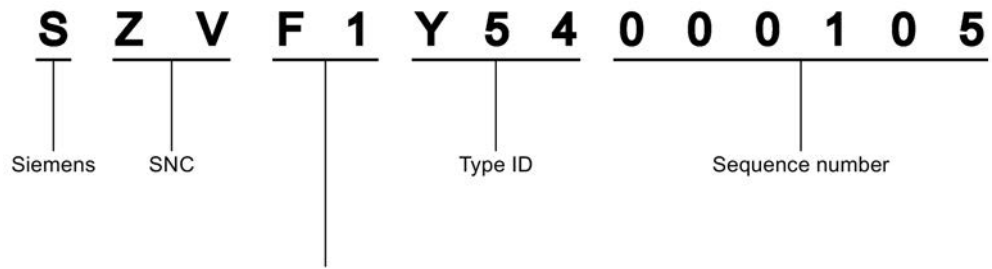

Production data (year/month)

Code *	Calendar year	Code *	Month
A	1990, 2010	1	January
B	1991, 2011	2	February
C	1992, 2012	3	March
D	1993, 2013	4	April
E	1994, 2014	5	May
F	1995, 2015	6	June
H	1996, 2016	7	July
J	1997, 2017	8	August
K	1998, 2018	9	September
L	1999, 2019	0	October
M	2000, 2020	N	November
N	2001, 2021	D	December
P	2002, 2022	* In accordance with DIN EN 60062	
R	2003, 2023		
S	2004, 2024		
T	2005, 2025		
U	2006, 2026		
V	2007, 2027		
W	2008, 2028		
X	2009, 2029		

2.1.2 Motor components

Components in the SIMOTICS S-1FL6 low inertia motor package

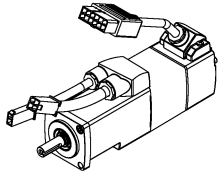
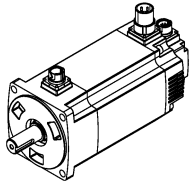
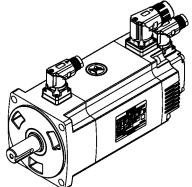
Component	Illustration	Rated power (kW)	Shaft height (mm)	Article number	
SIMOTICS S-1FL6, low inertia		0.05/0.1	20	1FL6022-2AF21-1□□1 1FL6024-2AF21-1□□1	
		0.2/0.4	30	1FL6032-2AF21-1□□1 1FL6034-2AF21-1□□1	
		0.75/1.0	40	1FL6042-2AF21-1□□1 1FL6044-2AF21-1□□1	
			1.5/2.0	50	1FL6052-2AF21-0□□1 1FL6054-2AF21-0□□1
				1.5/2.0	50
		User documentation		SIMOTICS S-1FL6 Servo Motors Installation Guide	

Components in the SIMOTICS S-1FL6 high inertia motor package

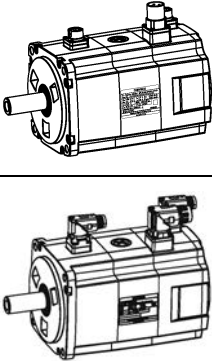
Component	Illustration	Rated power (kW)	Shaft height (mm)	Article number				
SIMOTICS S-1FL6, high inertia		0.4/0.75	45	1FL6042-1AF61-	<input type="checkbox"/>	□□1		
				1FL6044-1AF61-	<input type="checkbox"/>	□□1		
		0.75/1.0/1.5/1.7 5/2.0	65	1FL6061-1AC61-	<input type="checkbox"/>	□□1		
				1FL6062-1AC61-	<input type="checkbox"/>	□□1		
				1FL6064-1AC61-	<input type="checkbox"/>	□□1		
				1FL6066-1AC61-	<input type="checkbox"/>	□□1		
				1FL6067-1AC61-	<input type="checkbox"/>	□□1		
		2.5/3.5/5.0/7.0	90	1FL6090-1AC61-	<input type="checkbox"/>	□□1		
				1FL6092-1AC61-	<input type="checkbox"/>	□□1		
				1FL6094-1AC61-	<input type="checkbox"/>	□□1		
				1FL6096-1AC61-	<input type="checkbox"/>	□□1		
				Straight connectors with a fixed outlet direction			0	
				Angular connectors with a flexible outlet direction			2	
		User documentation	SIMOTICS S-1FL6 Servo Motors Installation Guide					

Motor rating plate (example)

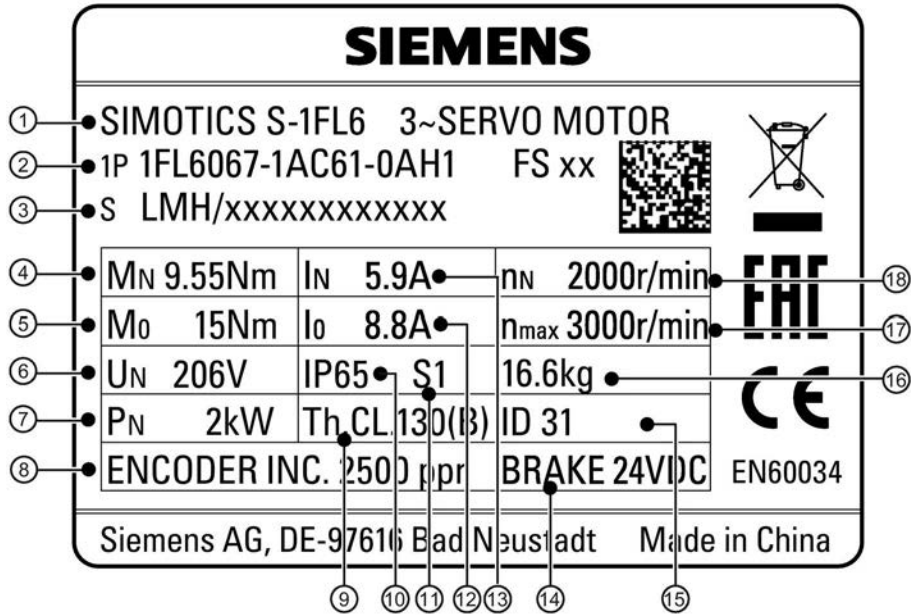

- | | |
|-------------------------------|------------------------|
| ① Motor type | ⑩ Degree of protection |
| ② Article number | ⑪ Motor operating mode |
| ③ Serial number | ⑫ Stall current |
| ④ Rated torque | ⑬ Rated current |
| ⑤ Stall torque | ⑭ Holding brake |
| ⑥ Rated voltage | ⑮ Motor ID |
| ⑦ Rated power | ⑯ Weight |
| ⑧ Encoder type and resolution | ⑰ Maximum speed |
| ⑨ Thermal class | ⑱ Rated speed |

Article number explanation

1 F L 6 0 6 7 - 1 A C 6 1 - 0 A H 1

Shaft height (SH)

Symbol	SH	Inertia type
02	20 mm	Low
03	30 mm	Low
04	40 mm	Low
	45 mm	High
05	50 mm	Low
06	65 mm	High
09	90 mm	High

Inertia type

Symbol	Type
1	High
2	Low

Supply voltage

Symbol	Voltage
2	200 V
6	400 V

Rated speed

Symbol	Rated speed
C	2000 rpm
F	3000 rpm

Rated torque

Symbol	Rated torque, SH
0	11.9 Nm, SH90
1	3.58 Nm, SH65
2	0.16 Nm, SH20
	0.64 Nm, SH30
	1.27 Nm, SH45
	2.39 Nm, SH40
	4.78 Nm, SH50
	4.78 Nm, SH65
	16.7 Nm, SH90
4	0.32 Nm, SH20
	1.27 Nm, SH30
	2.39 Nm, SH45
	3.18 Nm, SH40
	6.37 Nm, SH50
	7.16 Nm, SH65
	23.9 Nm, SH90
6	8.36 Nm, SH65
	33.4 Nm, SH90
7	9.55 Nm, SH65

Connection type

Symbol	Connection type
0	Straight connectors with a fixed outlet direction
1	Cable outlet
2	Angular connectors with a flexible outlet direction

Encoder type

Symbol	Encoder type
A	Incremental encoder TTL 2500 ppr
M	Absolute encoder single-turn 21-bit
L	Absolute encoder 20-bit + 12-bit multi-turn

Mechanics

Symbol	Mechanics
G	Plain shaft, without brake
H	Plain shaft, with brake
A	Shaft with key (half-key balancing), without brake
B	Shaft with key (half-key balancing), with brake

Protection degree

Symbol	Protection degree
1	IP65, with shaft oil seal

2.2 Device combination

V90 PN 200 V servo system

SIMOTICS S-1FL6 low inertia servo motors					SINAMICS V90 PN 200 V servo drives		MOTION-CONNECT 300 pre-assembled cables					
Rated torque (Nm)	Rated power (kW)	Rated speed (rpm)	Shaft height (mm)	Article No. 1FL60		Article No. 6SL321 0-5	Frame size	Power cable	Brake cable	Encoder cable		
								Article No. 6FX3002-5	Article No. 6FX3002-5	Article No. 6FX3002-2		
0.16	0.05	3000	20	22-2AF21-1	<input type="checkbox"/>	<input type="checkbox"/>	FB10-1UF1	FSA	CK01-1AD0 (3 m)	BK02-1AD0 (3 m)	<input type="checkbox"/>	20-1AD0 (3 m)
0.32	0.1	3000		24-2AF21-1	<input type="checkbox"/>	<input type="checkbox"/>						
0.64	0.2	3000	30	32-2AF21-1	<input type="checkbox"/>	<input type="checkbox"/>	FB10-4UF1	FSC	CK01-1BA0 (10 m)	BK02-1BA0 (10 m)	20-1BA0 (10 m)	
1.27	0.4	3000		34-2AF21-1	<input type="checkbox"/>	<input type="checkbox"/>						FB11-0UF1
2.39	0.75	3000	40	42-2AF21-1	<input type="checkbox"/>	<input type="checkbox"/>	FB11-5UF0	FSD	CK31-1AD0 (3 m)	BL02-1AD0 (3 m)	<input type="checkbox"/>	
3.18	1	3000		44-2AF21-1	<input type="checkbox"/>	<input type="checkbox"/>						FB12-0UF0
4.78	1.5	3000	50	52-2AF21-0 ¹⁾	<input type="checkbox"/>	<input type="checkbox"/>	FB12-0UF0	FSD	CK31-1BA0 (10 m)	BL02-1BA0 (10 m)	10-1BA0 (10 m)	
6.37	2	3000		54-2AF21-0 ¹⁾	<input type="checkbox"/>	<input type="checkbox"/>						FB11-5UF0
4.78	1.5	3000	50	52-2AF21-2 ²⁾	<input type="checkbox"/>	<input type="checkbox"/>	FB11-5UF0	FSD	CK32-1AD0 (3 m)	BL03-1AD0 (3 m)	<input type="checkbox"/>	
6.37	2	3000		54-2AF21-2 ²⁾	<input type="checkbox"/>	<input type="checkbox"/>						FB12-0UF0
Incremental encoder TTL 2500 ppr					A				Incremental encoder TTL 2500 ppr	CT		
Absolute encoder single-turn 21-bit					M				Absolute encoder single-turn 21-bit	DB		

- 1) Low inertia motor with straight connectors
- 2) Low inertia motor with angular connectors

V90 PN 400 V servo system

SIMOTICS S-1FL6 high inertia servo motors with straight connectors					SINAMICS V90 PN 400 V servo drives			MOTION-CONNECT 300 pre-assembled cables					
Rated torque (Nm)	Rated power (kW)	Rated speed (rpm)	Shaft height (mm)	Article No. 1FL60		Article No. 6SL321 0-5	Frame size	Power cable	Brake cable	Encoder cable			
								Article No. 6FX3002-5	Article No. 6FX3002-5	Article No. 6FX3002-2			
1.27	0.4	3000	45	42-1AF61-0	<input type="checkbox"/>	<input type="checkbox"/>	FE10-4UF0	FSA	CL01-1AD0 (3 m)	BL02-1AD0 (3 m)	<input type="checkbox"/>	10-1AD0 (3 m)	
2.39	0.75	3000		44-1AF61-0	<input type="checkbox"/>	<input type="checkbox"/>	FE10-8UF0	FSA	CL01-1AF0 (5 m)	BL02-1AF0 (5 m)			10-1AF0 (5 m)
3.58	0.75	2000	65	61-1AC61-0	<input type="checkbox"/>	<input type="checkbox"/>	FE11-0UF0	FSB	CL01-1AH0 (7 m)	BL02-1AH0 (7 m)	<input type="checkbox"/>	10-1AH0 (7 m)	
4.78	1.0	2000		62-1AC61-0	<input type="checkbox"/>	<input type="checkbox"/>			CL01-1BA0 (10 m)	BL02-1BA0 (10 m)		10-1BA0 (10 m)	
									CL01-1BF0 (15 m)	BL02-1BF0 (15 m)		10-1BF0 (15 m)	
									CL01-1CA0 (20 m)	BL02-1CA0 (20 m)		10-1CA0 (20 m)	
7.16	1.5	2000		64-1AC61-0	<input type="checkbox"/>	<input type="checkbox"/>	FE11-5UF0	FSC	CL11-1AD0 (3 m)				
8.36	1.75	2000		66-1AC61-0	<input type="checkbox"/>	<input type="checkbox"/>			CL11-1AF0 (5 m)				
9.55	2.0	2000	67-1AC61-0	<input type="checkbox"/>	<input type="checkbox"/>	FE12-0UF0	CL11-1AH0 (7 m)						
11.9	2.5	2000	90	90-1AC61-0	<input type="checkbox"/>	<input type="checkbox"/>		CL11-1BA0 (10 m)					
16.7	3.5	2000		92-1AC61-0	<input type="checkbox"/>	<input type="checkbox"/>	FE13-5UF0	CL11-1BF0 (15 m)					
23.9	5.0	2000		94-1AC61-0	<input type="checkbox"/>	<input type="checkbox"/>	FE15-0UF0	CL11-1CA0 (20 m)					
33.4	7.0	2000		96-1AC61-0	<input type="checkbox"/>	<input type="checkbox"/>	FE17-0UF0						
Incremental encoder TTL 2500 ppr					A				Incremental encoder TTL 2500 ppr		CT		
Absolute encoder 20-bit + 12-bit multi-turn					L				Absolute encoder 20-bit + 12-bit multi-turn		DB		

SIMOTICS S-1FL6 high inertia servo motors with angular connectors					SINAMICS V90 PN 400 V servo drives			MOTION-CONNECT 300 pre-assembled cables				
Rated torque (Nm)	Rated power (kW)	Rated speed (rpm)	Shaft height (mm)	Article No. 1FL60		Article No. 6SL321 0-5	Frame size	Article No. 6FX3002-5	Article No. 6FX3002-5	Article No. 6FX3002-2		
1.27	0.4	3000	45	42-1AF61-2	<input type="checkbox"/>	<input type="checkbox"/>	FE10-4UF0	FSA	CL02-1AD0 (3 m)	BL03-1AD0 (3 m)	<input type="checkbox"/> <input type="checkbox"/> <input type="checkbox"/>	-1AD0 (3 m)
2.39	0.75	3000		44-1AF61-2	<input type="checkbox"/>	<input type="checkbox"/>	FE10-8UF0	FSA	CL02-1AF0 (5 m)	BL03-1AF0 (5 m)	<input type="checkbox"/>	-1AF0 (5 m)
3.58	0.75	2000	65	61-1AC61-2	<input type="checkbox"/>	<input type="checkbox"/>	FE11-0UF0	FSB	CL02-1AH0 (7 m)	BL03-1AH0 (7 m)	<input type="checkbox"/>	-1AH0 (7 m)
4.78	1.0	2000		62-1AC61-2	<input type="checkbox"/>	<input type="checkbox"/>			CL02-1BA0 (10 m)	BL03-1BA0 (10 m)		-1BA0 (10 m)
7.16	1.5	2000		64-1AC61-2	<input type="checkbox"/>	<input type="checkbox"/>	FE11-5UF0		CL12-1AD0 (3 m)	BL03-1BF0 (15 m)		-1BF0 (15 m)
8.36	1.75	2000		66-1AC61-2	<input type="checkbox"/>	<input type="checkbox"/>	FE12-0UF0		CL12-1AF0 (5 m)	BL03-1CA0 (20 m)		-1CA0 (20 m)
9.55	2.0	2000		67-1AC61-2	<input type="checkbox"/>	<input type="checkbox"/>			CL12-1AH0 (7 m)			
11.9	2.5	2000		90	90-1AC61-2	<input type="checkbox"/>	<input type="checkbox"/>		FSC	CL12-1BA0 (10 m)		
16.7	3.5	2000	92-1AC61-2		<input type="checkbox"/>	<input type="checkbox"/>	FE13-5UF0	CL12-1BF0 (15 m)				
23.9	5.0	2000	94-1AC61-2		<input type="checkbox"/>	<input type="checkbox"/>	FE15-0UF0	CL12-1CA0 (20 m)				
33.4	7.0	2000	96-1AC61-2		<input type="checkbox"/>	<input type="checkbox"/>	FE17-0UF0					
Incremental encoder TTL 2500 ppr					A				Incremental encoder TTL 2500 ppr	CT12		
Absolute encoder 20-bit + 12-bit multi-turn					L				Absolute encoder 20-bit + 12-bit multi-turn	DB10		

Note

You can select a SINAMICS V90 PN servo drive for all the SIMOTICS S-1FL6 servo motors whose rated power values are equal to or smaller than that specified as matching with this servo drive in the table above.

2.3 Product overview

SINAMICS V90 PN servo drives

- SINAMICS V90 PN 200V variant
FSA and FSB

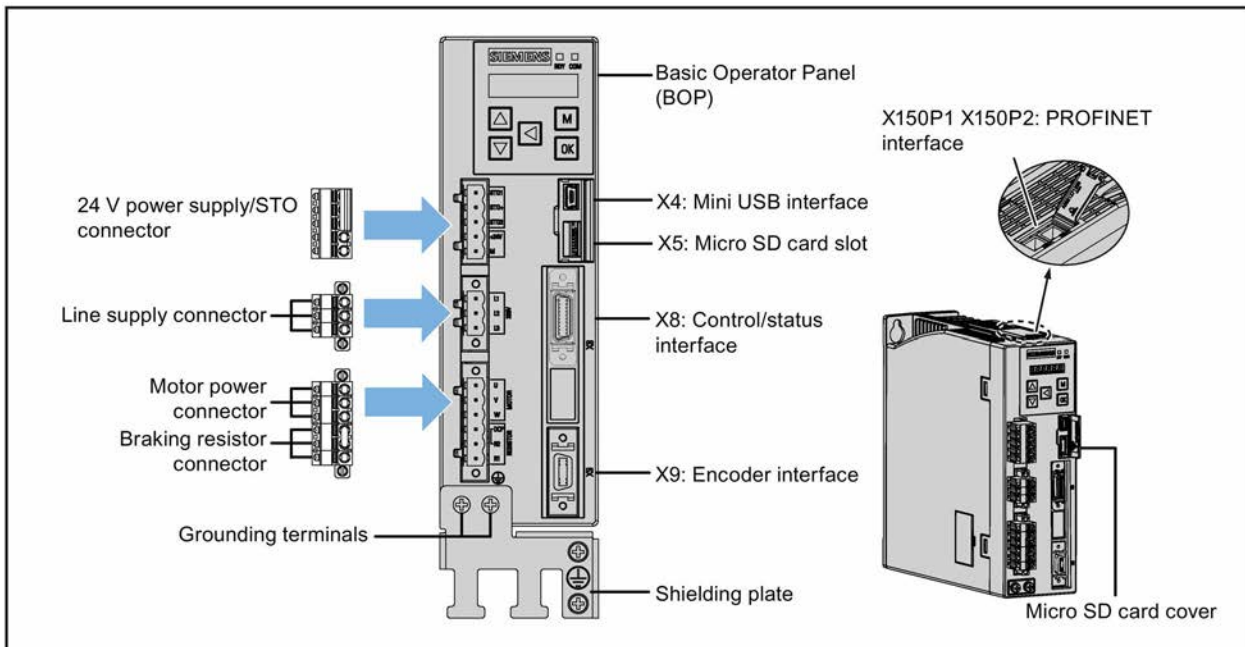

FSC and FSD

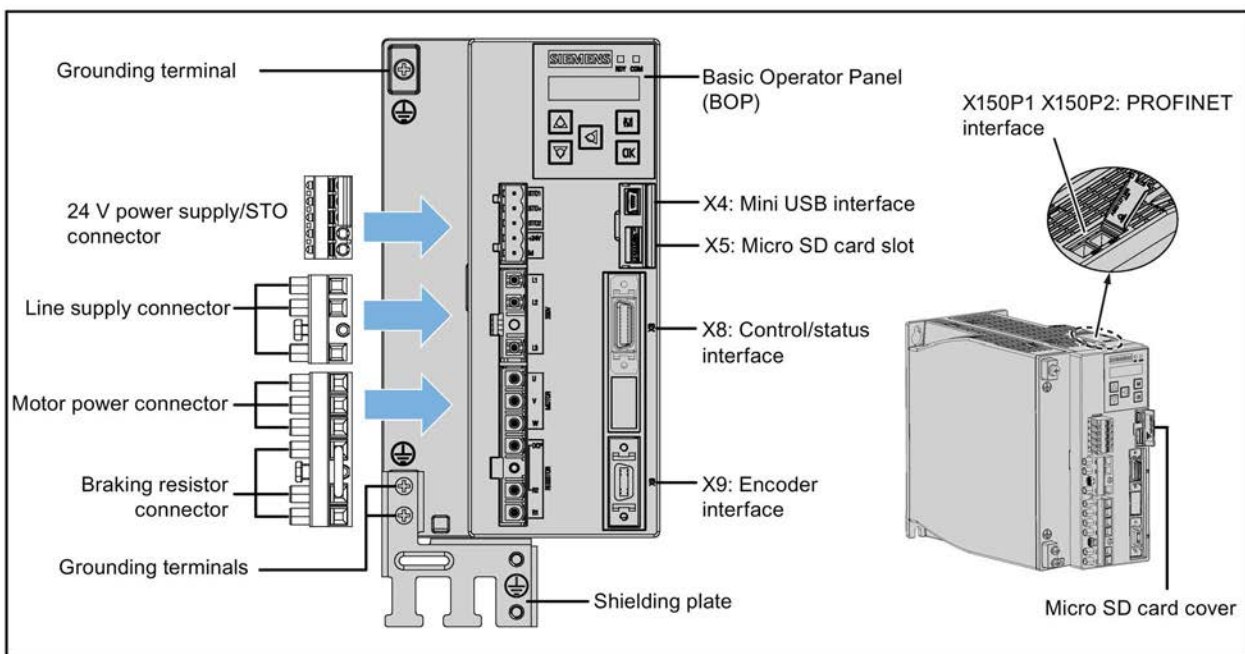

- SINAMICS V90 PN 400V variant
FSA and FSA

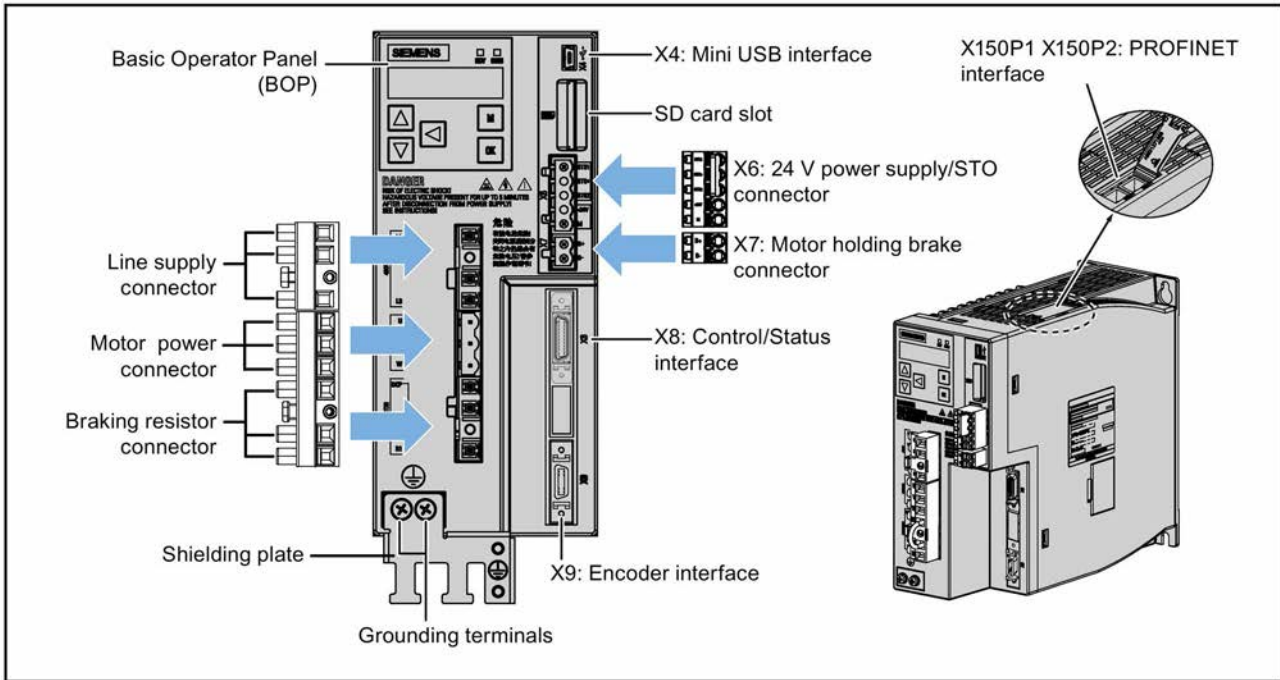

FSB and FSC

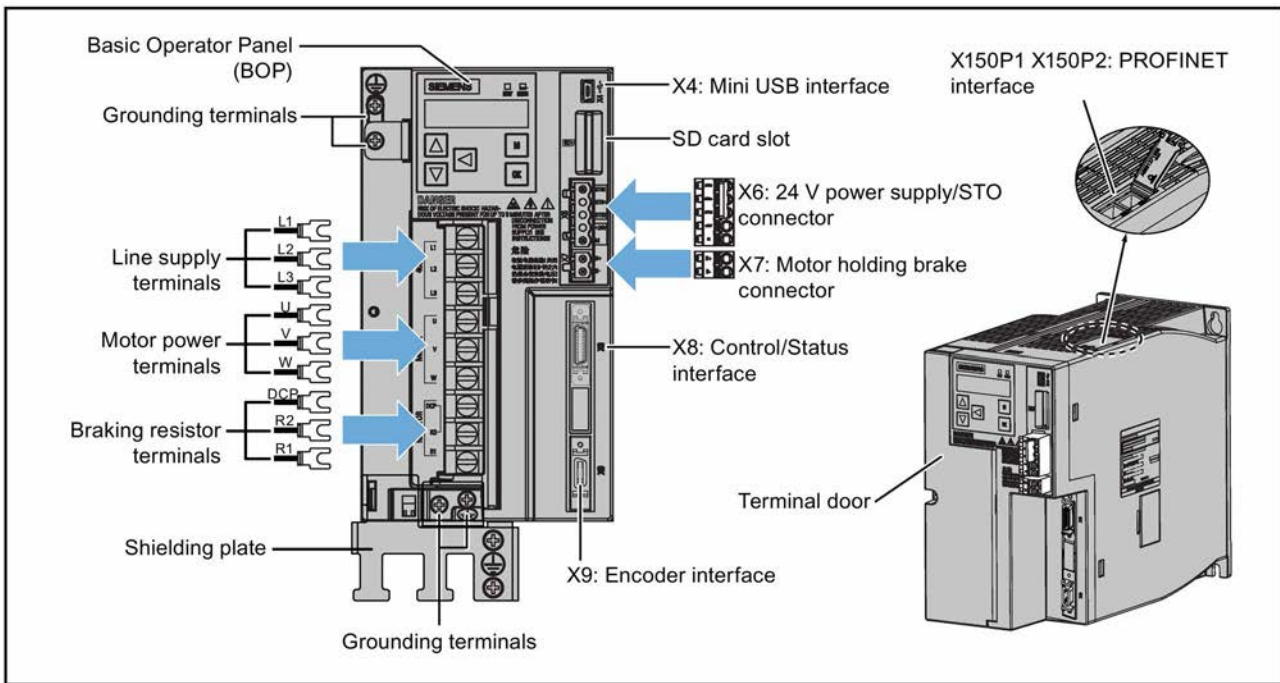

SIMOTICS S-1FL6 servo motors

- Low inertia motors

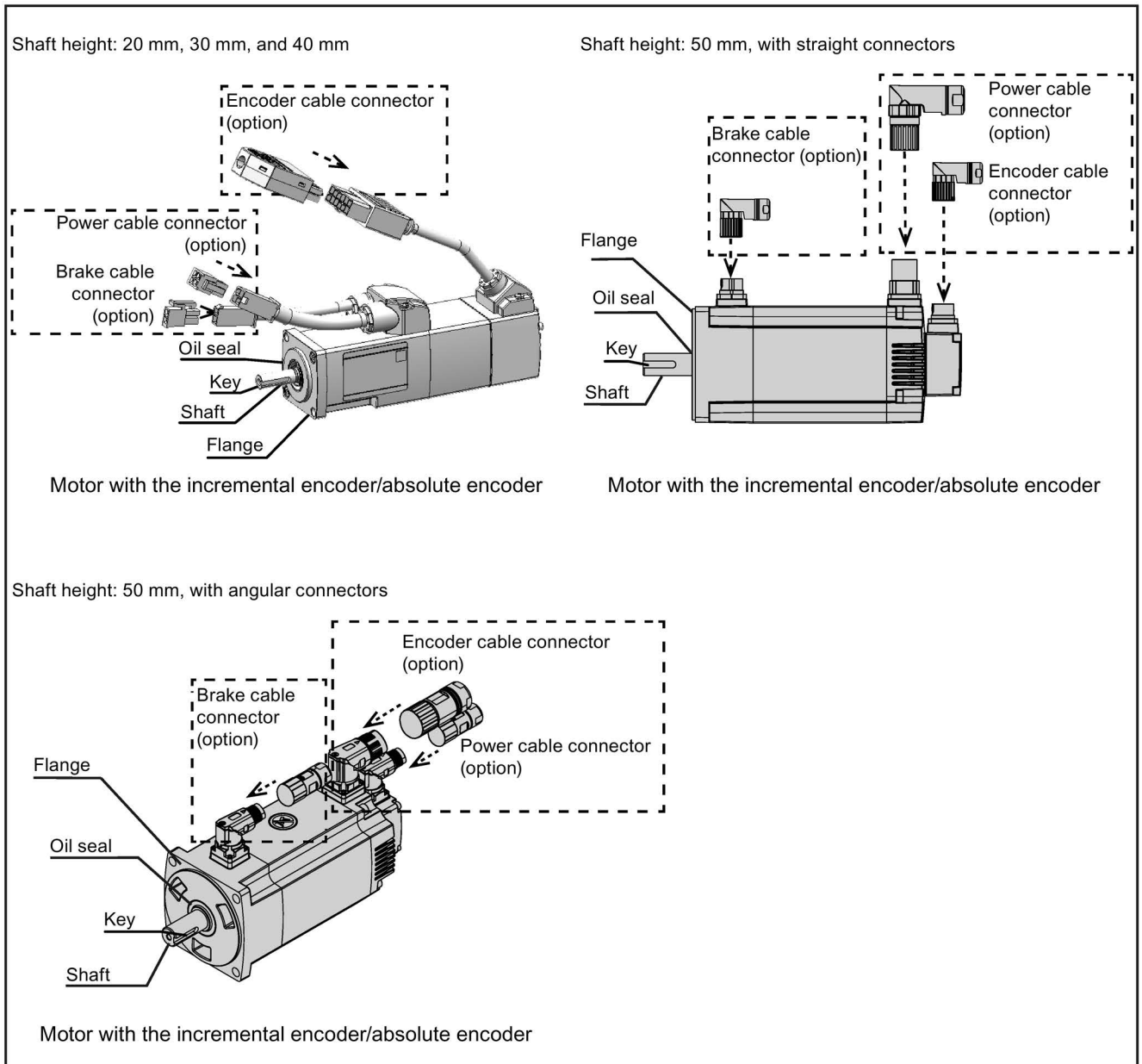

- High inertia motors with straight connectors

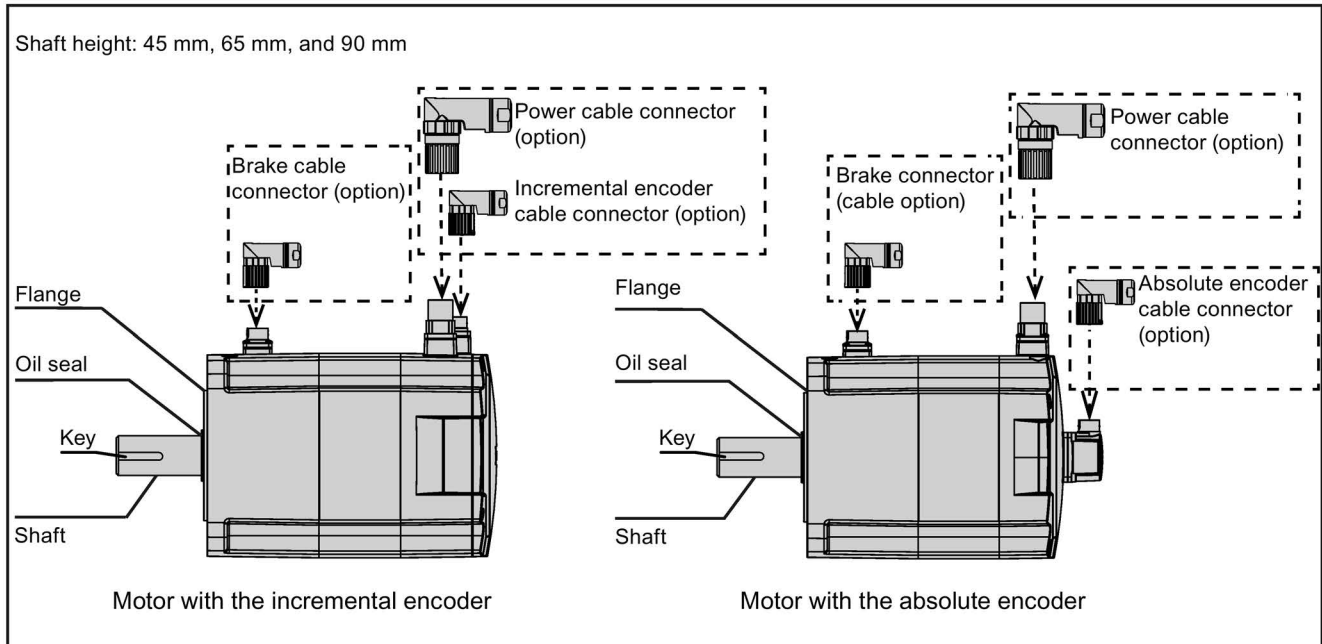



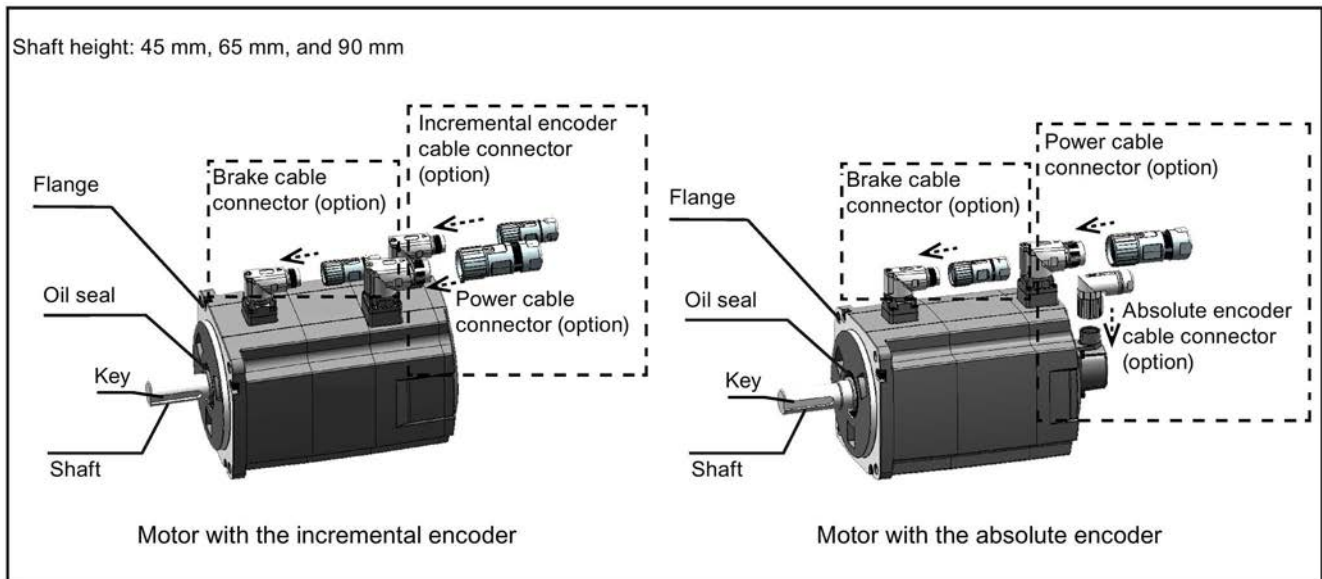







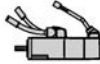

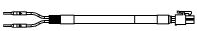

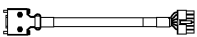

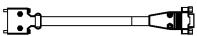

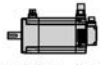
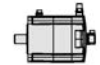

- High inertia motors with angular connectors



2.4 Accessories

2.4.1 MOTION-CONNECT 300 cables and connectors

Cable connectors (drive side)		MOTION-CONNECT 300 cables					Cable connectors (motor side)		
Type	Article No. 6FX2003 -	Type	Article No. 6FX3002-		Illustration (left: drive side; right: motor side)	Used for (SIMOTICS S-1FL6)	Type	Article No. 6FX2003 -	
-	-	Power cable	5CK01-1		0		Low inertia:  0.05 kW to 1 kW	Power connector	0LL12
-	-	Brake cable	5BK02-1		0			Brake connector	0LL52
Encoder connector	0SB14	Incremental encoder cable	2CT20-1		0			Incremental encoder connector	0SL12
		Absolute encoder cable	2DB20-1		0			Absolute encoder connector	0DB12
-	-	Power cable	5CK31-1		0	For low inertia motors of 1.5 kW to 2 kW: 	Low inertia (with straight connectors):  1.5 kW to 2 kW High inertia (with straight connectors):  0.4 kW to 7 kW	Power connector	0LL11
			5CL01-1		0	For high inertia motors of 0.4 kW to 1 kW: 			
			5CL11-1		0	For high inertia motors of 1.5 kW to 7 kW: 			
-	-	Brake cable	5BL02-1		0			Brake connector	0LL51
Encoder connector	0SB14	Incremental encoder cable	2CT10-1		0			Incremental encoder connector	0SL11
		Absolute encoder cable	2DB10-1		0			Absolute encoder connector	0DB11

Cable connectors (drive side)		MOTION-CONNECT 300 cables					Cable connectors (motor side)		
Type	Article No. 6FX2003	Type	Article No. 6FX3002-		Illustration (left: drive side; right: motor side)	Used for (SIMOTICS S-1FL6)	Type	Article No. 6FX2003	
-	-	Power cable	5CK32-1		0	For low inertia motors of 1.5 kW to 2 kW: 	Low inertia (with straight connectors): 1.5 kW to 2 kW High inertia (with angular connectors): 0.4 kW to 7 kW	Power connector	0LL13
			5CL02-1		0	For high inertia motors of 0.4 kW to 1 kW: 			
			5CL12-1		0	For high inertia motors of 1.5 kW to 7 kW: 			
-	-	Brake cable	5BL03-1		0			Brake connector	0LL53
Encoder connector	0SB14	Incremental encoder cable	2CT12-1		0			Incremental encoder connector	0SL13
		Absolute encoder cable	2DB12-1		0	For low inertia motors of 1.5 kW to 2 kW 		Absolute encoder connector	0DB13
			2DB10-1		0	For high inertia motors of 0.4 kW to 7 kW 		Absolute encoder connector	0DB11
Length ¹⁾									
3 m			AD	¹⁾ Cables with a maximum length of 20 m are provided at delivery. You can also make your own cables with a maximum length of 30 m, which are not tested by Siemens. ²⁾ Cables with lengths of 7 m and 15 m are only supplied for high inertia motors.					
5 m			AF						
7 m ²⁾			AH						
10 m			BA						
15 m ²⁾			BF						
20 m			CA						

For more information about how to assemble cable connectors on both the drive and motor sides, see Sections "Assembly of cable terminals on the drive side (Page 313)" and "Assembly of cable connectors on the motor side (Page 316)".

2.4.2 PROFINET cable and connector



The cable is used to connect the drive to a controller.

Name	Article number	Length (m)
SINAMICS V90 PROFINET I/O connector (20 pins)	6SL3260-2MA00-0VA0	-
SINAMICS V90 PROFINET I/O cable (20 pins)	6SL3260-4MA00-1VB0	1
RJ45 data plug-in connector, with 180° (straight) cable outlet	6GK1901-1BB10-2AA0	-
Standard bus cable (4-core), sold by meter, not assembled	6XV1840-2AH10	-
Preassembled PROFINET cable, with two RJ45 plug-180 connectors	6XV1871-5BH10	1

2.4.3 Connectors used on the drive front panel

If you need a new connector that used on the drive front panel, you can order a connector kit from Siemens.

Connector kits

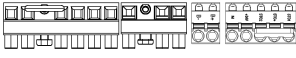
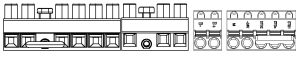
Illustration	Used for (SINAMICS servo drive)	Article number
200 V variant		
	FSA, FSB	6SL3200-0WT02-0AA0
	FSC, FSD	6SL3200-0WT03-0AA0
400 V variant		
	FSAA	6SL3200-0WT00-0AA0
	FSA	6SL3200-0WT01-0AA0

- 1) You can obtain the connectors for SINAMICS V90 400V servo drives of FSB and FSC from the connector kits for SINAMICS V90 400V servo drives of FSAA or FSA.

2.4.4 External 24 VDC power supply

A 24 VDC power supply is needed to supply the V90 PN servo drive. Refer to the table below to select the power supply:

Parameter	Description
Without a holding brake	
Rated voltage (V)	24 (-15% to +20%)
Maximum current (A)	1.5
With a holding brake	
Rated voltage (V)	24 (-15% to +20%) ¹⁾
Maximum current (A)	1.5 + motor holding brake rated current (See Section "Technical data - servo motors (Page 60)")

- ¹⁾ The minimum voltage of 24 VDC -10% must be available at the connector on the motor side in order to guarantee that the brake reliably opens. If the maximum voltage of 24 VDC +10% is exceeded, then the brake could re-close. The voltage drop along the brake feeder cable must be taken into consideration. The voltage drop ΔU for copper cables can be approximately calculated as follows:

$$\Delta U [V] = 0.042 \Omega \cdot \text{mm}^2/\text{m} \cdot (l/q) \cdot I_{\text{Brake}}$$

Where: l = Cable length [m], q = Brake cable cross section [mm^2], I_{Brake} = DC current of brake [A]

2.4.5 Fuse/Type-E combination motor controller

A fuse/type-E combination motor controller/circuit breaker can be used to protect the system. Integral solid state short circuit protection does not provide branch circuit protection. Branch circuit protection must be provided in accordance with the National Electrical Code and any additional local codes. Refer to the table below for the selection of fuses, type-E combination motor controllers, and circuit breakers:

SINAMICS V90 PN 200 V variant

SINAMICS V90 PN		Recommended fuse		Type-E combination motor controller ¹⁾			
Frame size	Rated power (kW)	CE-compliant	UL/cUL-compliant listed (JDDZ) fuse	Rated current (A)	Rated voltage (VAC)	Rated power (hp)	Article number
1-phase, 200 VAC to 240 VAC							
FSA	0.1	3NA3 801 (6 A)	6 A	2.8 to 4	230/240	1/3	3RV 2011-1EA10
	0.2	3NA3 801 (6 A)	6 A	2.8 to 4	230/240	1/3	3RV 2011-1EA10
FSB	0.4	3NA3 803 (10 A)	10 A	5.5 to 8	230/240	1	3RV 2011-1HA10
FSC	0.75	3NA3 805 (16 A)	20 A	9 to 12.5	230/240	2	3RV 2011-1KA10

2.4 Accessories

SINAMICS V90 PN		Recommended fuse		Type-E combination motor controller ¹⁾			
Frame size	Rated power (kW)	CE-compliant	UL/cUL-compliant listed (JDDZ) fuse	Rated current (A)	Rated voltage (VAC)	Rated power (hp)	Article number
3-phase, 200 VAC to 240 VAC							
FSA	0.1	3NA3 801 (6 A)	6 A	2.8 to 4	230/240	3/4	3RV 2011-1EA10
	0.2	3NA3 801 (6 A)	6 A	2.8 to 4	230/240	3/4	3RV 2011-1EA10
FSB	0.4	3NA3 803 (10 A)	10 A	2.8 to 4	230/240	3/4	3RV 2011-1EA10
FSC	0.75	3NA3 805 (16 A)	20 A	5.5 to 8	230/240	2	3RV 2011-1HA10
FSD	1.0	3NA3 805 (16 A)	20 A	7 to 10	230/240	3	3RV 2011-1JA10
	1.5	3NA3 810 (25 A)	25 A	10 to 16	230/240	5	3RV 2011-4AA10
	2.0	3NA3 810 (25 A)	25 A	10 to 16	230/240	5	3RV 2011-4AA10

¹⁾ The above types for type-E combination motor controllers are listed in compliance with both CE and UL/cUL standards.

SINAMICS V90 PN 400 V variant

SINAMICS V90 PN		Recommended fuse type		Type-E combination motor controller ¹⁾			
Frame size	Rated power (kW)	CE-compliant	UL/cUL-compliant listed (JDDZ) fuse	Rated current (A)	Rated voltage (VAC)	Rated power (hp)	Article number
3-phase, 380 VAC to 480 VAC							
FSAA	0.4	3NA3 801 (6 A)	10 A	2.2 to 3.2	380/480	0.5	3RV 2021-1DA10
FSA	0.75	3NA3 801 (6 A)	10 A	2.8 to 4	380/480	1	3RV 2021-1EA10
	1.0	3NA3 803 (10 A)	10 A	3.5 to 5	380/480	1.34	3RV 2021-1FA10
FSB	1.5	3NA3 803 (10 A)	15 A	5.5 to 8	380/480	2	3RV 2021-1HA10
	2.0	3NA3 805 (16 A)	15 A	11 to 16	380/480	2.68	3RV 2021-4AA10
FSC	3.5	3NA3 807 (20 A)	25 A	14 to 20	380/480	4.7	3RV 2021-4BA10
	5.0	3NA3 807 (20 A)	25 A	14 to 20	380/480	6.7	3RV 2021-4BA10
	7.0	3NA3 810 (25 A)	25 A	20 to 25	380/480	9.4	3RV 2021-4DA10

¹⁾ The above types for Type-E combination motor controllers are listed in compliance with both CE and UL/cUL standards.

 WARNING
Requirements for United States/Canadian installations (UL/cUL)
Suitable for use on a circuit capable of delivering not more than 65000 rms Symmetrical Amperes, 480 VAC maximum for 400 V variants of drives or 240 VAC maximum for 200 V variant drives, when protected by the UL/cUL listed (JDDZ) fuse or type-E combination motor controller. For each frame size AA, A, B, C and D, use 75 °C copper wire only.
This equipment is capable of providing internal motor overload protection according to UL508C.
For Canadian (cUL) installations the drive mains supply must be fitted with any external recommended suppressor with the following features:
<ul style="list-style-type: none"> • Surge-protective devices; device shall be a Listed Surge-protective device (Category code VZCA and VZCA7) • Rated nominal voltage 480/277 VAC, 50/60 Hz, 3-phase; 120/208 VAC, 50/60 Hz, 1/3-phase • Clamping voltage VPR = 2000 V, IN = 3kA min, MCOV = 508 VAC, SCCR = 65 kA • Suitable for Type 2 SPD application • Clamping shall be provided between phases and also between phase and ground

2.4.6 Braking resistor

The SINAMICS V90 PN has a built-in braking resistor. The table below shows the information of the built-in resistor:

SINAMICS V90 PN	Resistance (Ω)	Max. power (kW)	Rated power (W)	Max. energy (kJ)
1/3-phase, 200 VAC to 240 VAC				
FSA (0.2 kW)	150	1.09	13.5	0.55
FSB	100	1.64	20.5	0.82
FSC	50	3.28	41	1.64
3-phase, 200 VAC to 240 VAC				
FSD (1 kW)	50	3.28	41	1.64
FSD (1.5 kW to 2 kW)	25	6.56	82	3.28
3-phase, 380 VAC to 480 VAC				
FSAA	533	1.2	17	1.8
FSA	160	4	57	6
FSB	70	9.1	131	13.7
FSC	27	23.7	339	35.6

Note

The 200 V variant servo drive with rated power of 0.1 kW does not have a built-in resistor.

When the motor works in a fast round-trip process, the voltage of the line supply increases. The braking resistor starts to work if the voltage reaches the set threshold. The temperature of the heat sink increases (>100 °C) when the braking resistor is working. If alarms A52901 and A5000 appear at the same time, you need to switch the built-in braking resistor to the external braking resistor. You can select a standard braking resistor according to the table below:

SINAMICS V90 PN	Minimum resistance (Ω)	Max. power (kW)	Rated power (W)	Max. energy (kJ)
1/3-phase, 200 VAC to 240 VAC				
FSA	150	1.09	20	0.8
FSB	100	1.64	21	1.23
FSC	50	3.28	62	2.46
3-phase, 200VAC to 240 VAC				
FSD (1 kW)	50	3.28	62	2.46
FSD (1.5 kW to 2 kW)	25	6.56	123	4.92
3-phase, 380 VAC to 480 VAC				
FSA	533	1.2	30	2.4
FSA	160	4	100	8
FSB	70	9.1	229	18.3
FSC	27	23.7	1185	189.6

Note

When selecting a braking resistor, you must take into account the factors such as braking inertia, deceleration time, speed variation, and braking period according to your specific application and technology. The resistance of the selected braking resistor must not be lower than the minimum resistance listed above.

2.4.7 Filter

Siemens recommends you to use a line filter to protect the system from high frequency noise. The line filter restricts the conductive interference emitted from the SINAMICS V90 PN to the permissible values. The SINAMICS V90 PN drives with these external line filters have been tested in accordance with the emission requirements of the Category C2 environment. The conductive emissions and radiated emissions are in compliance with the Class A requirements of the EN 55011 standard.

Recommended line filters

SINAMICS V90 PN	Rated current (A)	Article number	Degree of protection
1-phase, 200 VAC to 240 VAC			
FSA	18	6SL3203-0BB21-8VA0	IP20
FSB			
FSC			
3-phase, 200 VAC to 240 VAC			
FSA	5	6SL3203-0BE15-0VA0	IP20
FSB			
FSC			
FSD	12	6SL3203-0BE21-2VA0	
3-phase, 380 VAC to 480 VAC			
FSA	5	6SL3203-0BE15-0VA0	IP20
FSA			
FSB	12	6SL3203-0BE21-2VA0	
FSC	20	6SL3203-0BE22-0VA0	

Outline dimensions (mm)

Filter used on the single phase power network

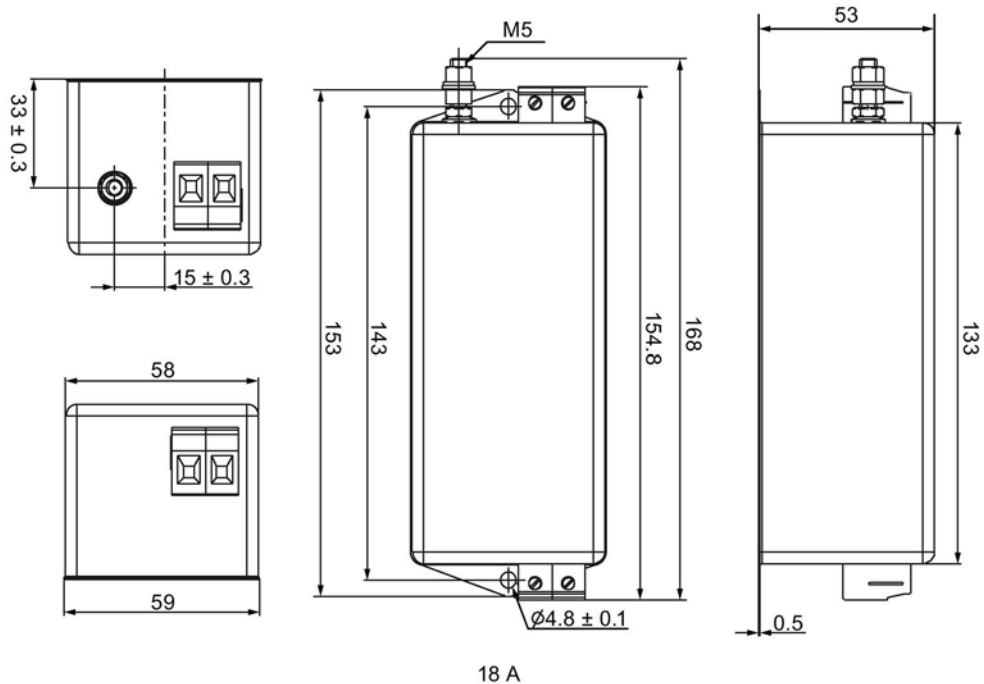

18 A

Filter used on the three phase power network

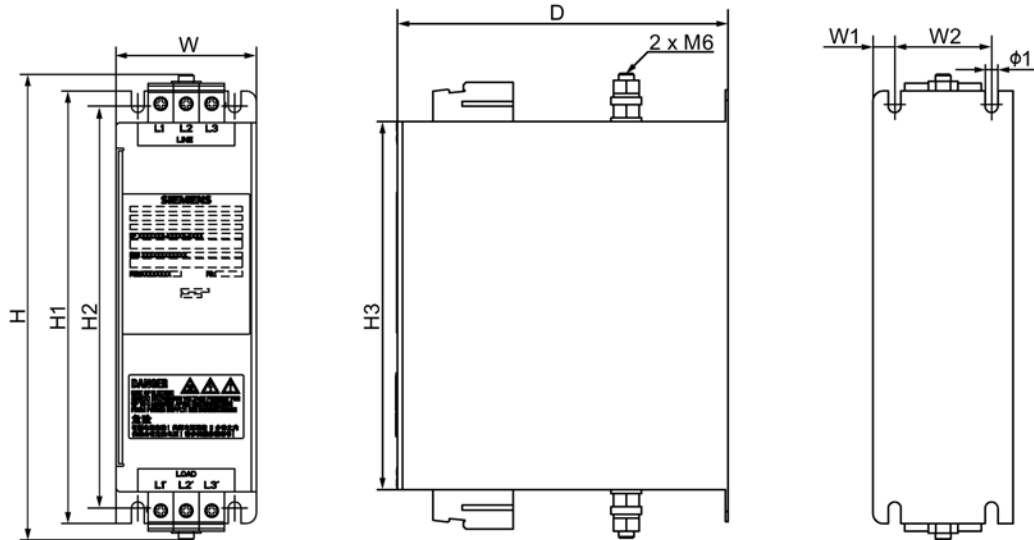

Rated current (A)	W	W1	W2	H	H1	H2	H3	D	ø1
5	55	8.5	38	184	170	158	145	130	5
12	75	8.5	58	184	170	158	145	140	5
20	60	10	40	259	250	240	220	130	5.5

Basic technical data

Parameter	Description
Filter used on the single phase power network	
Rated current	18 A
Rated voltage	Single phase 200 VAC to 240 VAC (-15% to +10%)
Line frequency	50/60 Hz (-10% to +10%)
Product standard	IEC 61800-5-1
Power loss	< 1.2 W
Package size (H × W × D)	230 mm × 95 mm × 90 mm
Filter used on the three phase power network	
Rated current	5 A 12 A 20 A
Rated voltage	Three phase 200 VAC to 480 VAC (-15% to +15%) Three phase 380 VAC to 480 VAC (-15% to +15%)
Line frequency	50/60 Hz (-10% to +10%)
Product standard	IEC 61800-5-1
Power loss	< 1 W < 3 W < 8 W
Package size (H × W × D)	543 mm × 318 mm × 351 mm

Insertion loss

Parameter	Description					
Rated current	5 A					
Noise frequency (MHz)	0.15	0.5	1.0	5.0	10	30
CM (dB)	60	65	55	45	35	20
DM (dB)	50	60	55	50	50	40
Rated current	12 A					
Noise frequency (MHz)	0.15	0.5	1.0	5.0	10	30
CM (dB)	60	70	70	55	45	15
DM (dB)	60	65	60	50	45	30
Rated current	18 A					
Noise frequency (MHz)	0.15	0.5	1.0	5.0	10	30
CM (dB)	32	70	82	88	81	90
DM (dB)	40	67	68	72	69	59
Rated current	20 A					
Noise frequency (MHz)	0.15	0.5	1.0	5.0	10	30
CM (dB)	60	60	60	55	35	15
DM (dB)	40	55	55	50	45	30

Connecting (example)

Filter used on the single phase power network

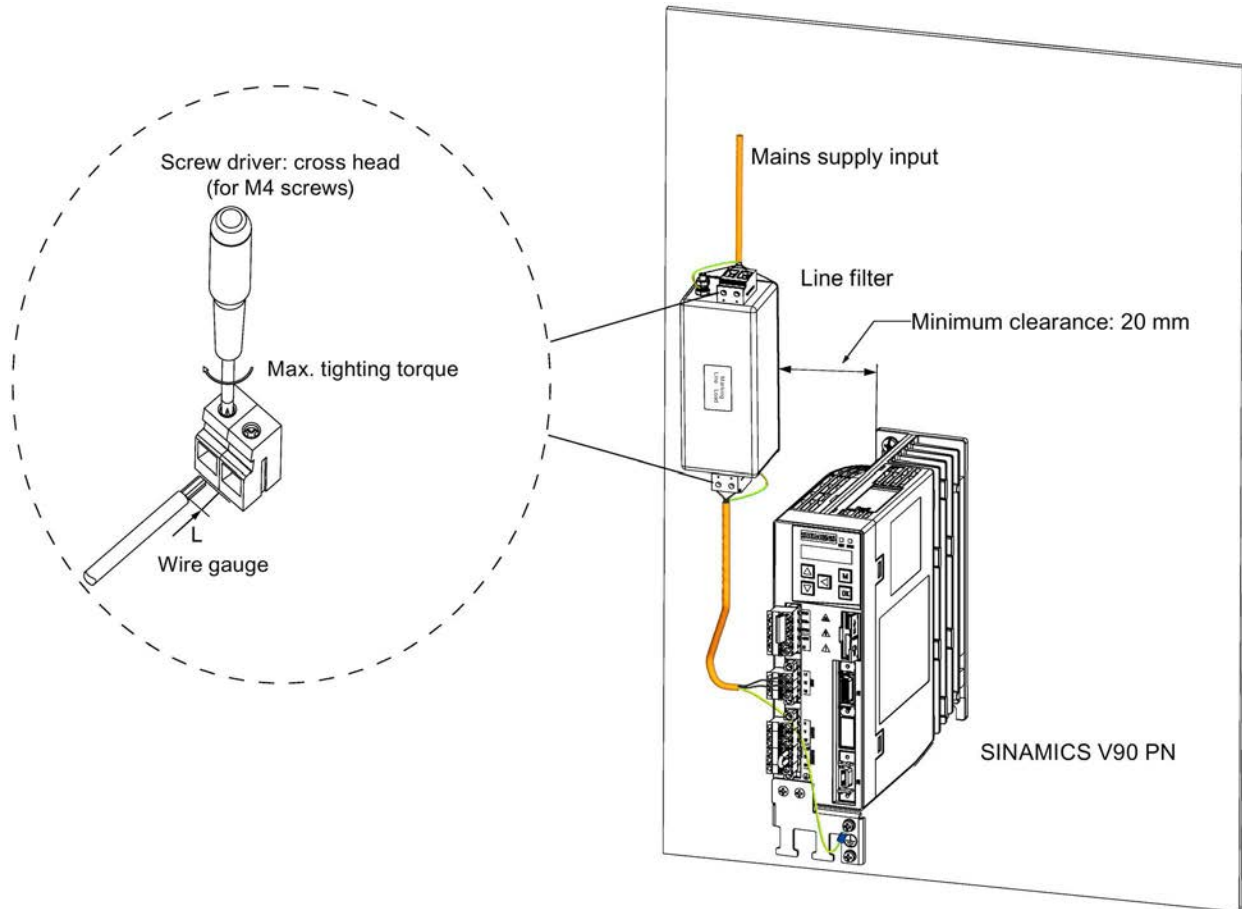

SINAMICS V90 PN 200 V	Rated current (A)	Screw driver	Max. tightening torque (Nm)	Wire gauge (AWG)	Stripping length L (mm)
6SL3210-5FB10-1UF1	18	Cross-tip (M4 screw)	1.5	22 to 20	8
6SL3210-5FB10-2UF1				22 to 20	
6SL3210-5FB10-1UF0					
6SL3210-5FB10-2UF0					
6SL3210-5FB10-4UF1				18 to 16	
6SL3210-5FB10-8UF0				14 to 12	

Filter used on the three phase power network

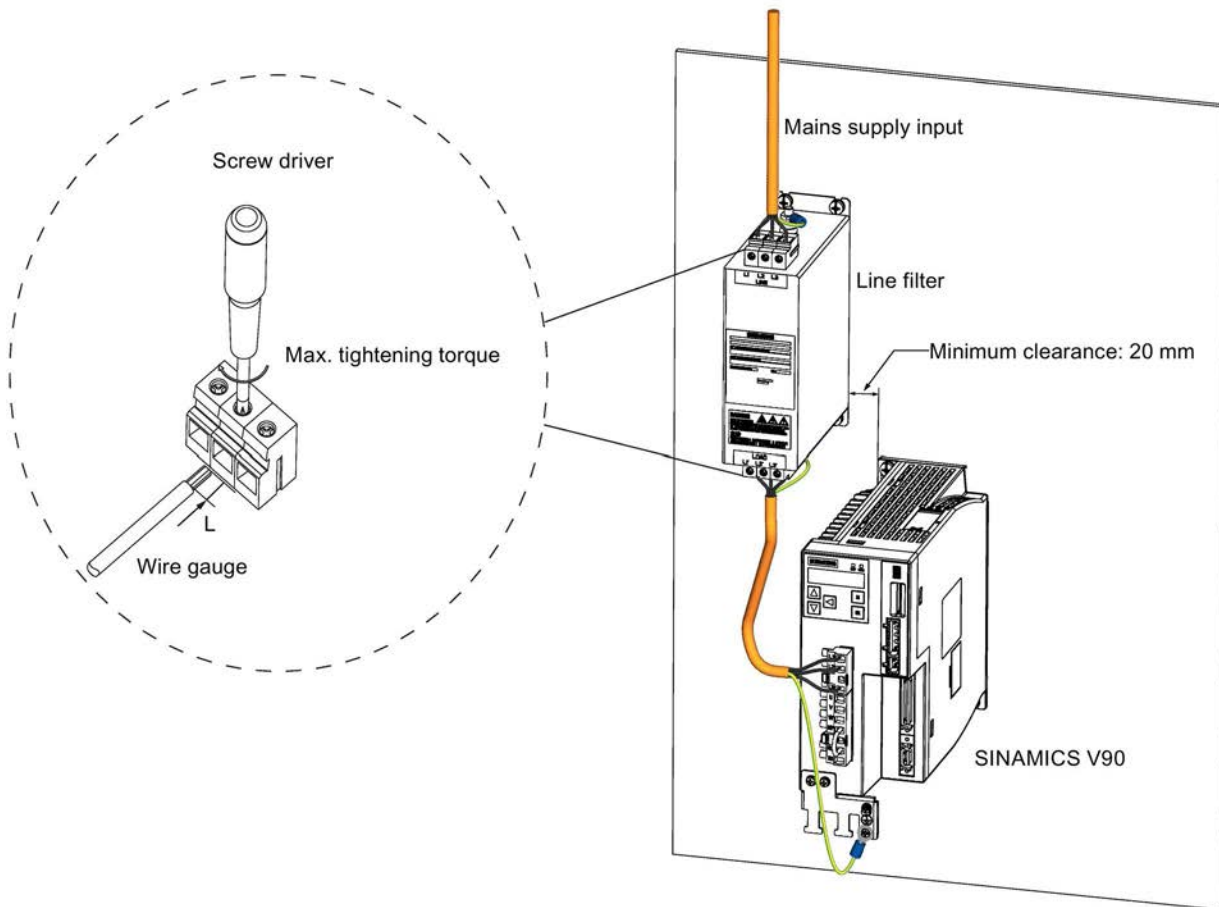

SINAMICS V90 PN	Rated current (A)	Screw driver	Max. tightening torque (Nm)	Wire gauge (AWG)	Stripping length L (mm)
200 V variant					
6SL3210-5FB10-1UF1	5	Cross-tip (M4 screw)	1.5	24 to 22	8
6SL3210-5FB10-2UF1					
6SL3210-5FB10-1UF0					
6SL3210-5FB10-2UF0				24 to 22	
6SL3210-5FB10-4UF1				22 to 20	
6SL3210-5FB10-8UF0				18 to 16	

SINAMICS V90 PN	Rated current (A)	Screw driver	Max. tightening torque (Nm)	Wire gauge (AWG)	Stripping length L (mm)
6SL3210-5FB11-0UF1	12	Cross-tip (M4 screw)	1.5	16 to 14	8
6SL3210-5FB11-5UF0				14 to 12	
6SL3210-5FB12-0UF0				14 to 12	
400 V variant					
6SL3210-5FE10-4UF0	5	Cross-tip (M4 screw)	1.5	21 to 19	8
6SL3210-5FE10-8UF0				18 to 17	
6SL3210-5FE11-0UF0				17 to 16	
6SL3210-5FE11-5UF0	12	Cross-tip (M4 screw)	1.5	15 to 14	8
6SL3210-5FE12-0UF0				13 to 12	
6SL3210-5FE13-5UF0	20	Cross-tip (M4 screw)	1.5	11 to 10	8
6SL3210-5FE15-0UF0				10 to 9	
6SL3210-5FE17-0UF0				10 to 9	

2.4.8 Micro SD card/SD card

Optionally a micro SD card/SD card can be used to copy drive parameters or perform a firmware update. Micro SD card is used for 200 V variant servo drive and SD card is used for 400 V variant servo drive. Siemens recommends you to use the Siemens SD card (article number: 6SL3054-4AG00-2AA0).

You can select high quality micro SD cards/SD cards with a maximum capacity of 32 GB from manufacturers such as Kingston or SanDisk.

2.4.9 Replacement fans

The table below lists the replacement fans for SINAMICS V90 PN servo drives.

SINAMICS V90 PN	Article number
3-phase, 200 VAC to 240 VAC	
FSD	6SL3200-0WF00-0AA0
3-phase, 380 VAC to 480 VAC	
FSB	6SL3200-0WF00-0AA0
FSC	6SL3200-0WF01-0AA0

2.5 Function list

Function	Description	Control mode
Basic positioner (EPOS) (Page 162)	Positions axes in absolute/relative terms with a motor encoder	EPOS
Speed control (S) (Page 183)	Flexibly controls motor speed and direction through PROFINET communication port	S
Safe Torque Off (STO) (Page 225)	Safely disconnects torque-generating motor power supply to prevent an unintentional motor restart	EPOS, S
One-button auto tuning (Page 232)	Estimates the machine characteristic and sets the closed loop control parameters (speed loop gain, speed integral compensation, filter if necessary, etc.) without any user intervention	EPOS, S
Real-time auto tuning (Page 237)	Estimates the machine characteristic and sets the closed loop control parameters (speed loop gain, speed integral compensation, filter if necessary, etc.) continuously in real time without any user intervention	EPOS, S
Resonance suppression (Page 241)	Suppresses the mechanical resonance, such as workpiece vibration and base shake	EPOS, S
Low frequency vibration suppression (Page 244)	Suppresses the low frequency vibration in the machine system	EPOS
Speed limit (Page 183)	Limits motor speed through internal speed limit commands (two groups)	EPOS, S
Torque limit (Page 184)	Limits motor torque through internal torque limit commands (two groups)	EPOS, S
Basic operator panel (BOP) (Page 131)	Displays servo status on a 6-digit 7-segment display	EPOS, S
External braking resistor - DCP, R1 (Page 116)	An external braking resistor can be used when the internal braking resistor is insufficient for regenerative energy	EPOS, S
Digital inputs/outputs (DIs/Dos) (Page 102)	Control signals and status signals can be assigned to four programmable digital inputs and two digital outputs	EPOS, S
PROFINET communication (Page 189)	Supports communication between the SINAMICS V90 PN servo drive and PLC with PROFINET communication protocol	EPOS, S
SINAMICS V-ASSISTANT	You can perform parameter settings, test operation, adjustment and other operations with a PC	EPOS, S

2.6 Technical data

2.6.1 Technical data - servo drives

2.6.1.1 SINAMICS V90 PN 200 V variant

General technical data

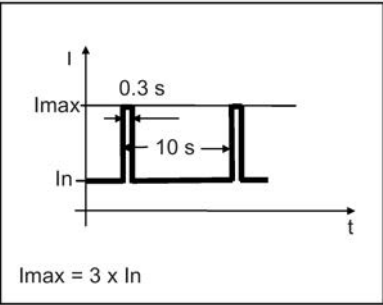
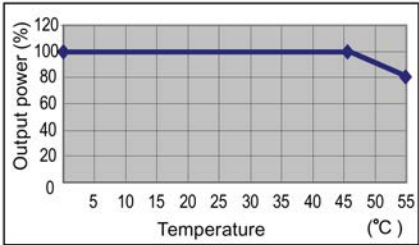
Parameter		Description	
Overload capability		300%	
		 <p style="text-align: center;">$I_{max} = 3 \times I_n$</p>	
Control system		Servo control	
Dynamic brake		Built-in	
Protective functions		Earthing fault protection, output short-circuit protection ¹⁾ , overvoltage/undervoltage protection ²⁾ , I ² t inverter, I ² t motor, IGBT overtemperature protection ³⁾	
Overvoltage criteria		Category III	
Speed control mode	Speed control range	Internal speed command 1:5000	
	Torque limit	Set through a parameter	
Environmental conditions	Surrounding air temperature	Operation	0 °C to 45 °C: without power derating 45 °C to 55 °C: with power derating
			
	Storage	-40 °C to +70 °C	
	Ambient humidity	Operation	< 90% (non-condensing)
Storage		90% (non-condensing)	

Parameter		Description														
	Operating environment	Indoors (without direct sunlight), free from corrosive gas, combustible gas, oil gas, or dust														
	Altitude	≤ 1000 m (without power derating) <div style="text-align: center;"> <table border="1"> <caption>Output power (%) vs Altitude (m)</caption> <thead> <tr> <th>Altitude (m)</th> <th>Output power (%)</th> </tr> </thead> <tbody> <tr> <td>0</td> <td>100</td> </tr> <tr> <td>1000</td> <td>95</td> </tr> <tr> <td>2000</td> <td>85</td> </tr> <tr> <td>3000</td> <td>75</td> </tr> <tr> <td>4000</td> <td>65</td> </tr> <tr> <td>5000</td> <td>60</td> </tr> </tbody> </table> </div>	Altitude (m)	Output power (%)	0	100	1000	95	2000	85	3000	75	4000	65	5000	60
	Altitude (m)	Output power (%)														
	0	100														
1000	95															
2000	85															
3000	75															
4000	65															
5000	60															
Degree of protection	IP 20															
Degree of pollution	Class 2															
Vibration	Operation	Shock	Operational area II Peak acceleration: 5 g, 30 ms and 15 g, 11 ms Quantity of shocks: 3 per direction \times 6 directions Duration of shock: 1 s													
		Vibration	Operational area II 10 Hz to 58 Hz: 0.075 mm deflection 58 Hz to 200 Hz: 1 g vibration													
	Product packaging	Vibration	2 Hz to 9 Hz: 3.5 mm deflection 9 Hz to 200 Hz: 1 g vibration Quantity of cycles: 10 per axis Sweep seed: 1 octave/min													
Certification																

- 1) Integral solid state short circuit protection does not provide branch circuit protection. Branch circuit protection must be provided in accordance with the National Electrical Code and any additional local codes.
- 2) The V90 PN 200 V servo drive has an overvoltage threshold of 410 VDC and an undervoltage threshold of 150 VDC; the V90 PN 400 V servo drive has an overvoltage threshold of 820 VDC and an undervoltage threshold of 320 VDC.
- 3) SINAMICS V90 PN does not support motor overtemperature protection. Motor overtemperature is calculated by I^2t and protected by the output current from the drive.

Specific technical data

Article No.	6SL3210-5FB...	10-1UF1	10-2UF1	10-4UF1	10-8UF0	11-0UF1	11-5UF0	12-0UF0	
Frame size		FSA	FSA	FSB	FSC	FSD	FSD	FSD	
Rated output current (A)		1.2	1.4	2.6	4.7	6.3	10.6	11.6	
Max. output current (A)		3.6	4.2	7.8	14.1	18.9	31.8	34.8	
Max. supported motor power (kW)		0.1	0.2	0.4	0.75	1.0	1.5	2.0	
Power loss ¹⁾	Main circuit (W)	8	15	33	48	65	105	113	
	Regenerative resistor (W)	5	5	7	9	13	25	25	
	Control circuit (W)	16	16	16	16	16	18	18	
	Total (W)	29	36	56	73	94	148	156	
Output frequency (Hz)		0 to 330							
Power supply	Voltage/frequency	FSA, FSB and FSC: single phase/three phase 200 VAC to 240 VAC, 50/60 Hz FSD: three phase 200 VAC to 240 VAC, 50/60 Hz							
	Permissible voltage fluctuation	-15% to +10%							
	Permissible frequency fluctuation	-10% to +10%							
	Permissible supply configuration	TN, TT, IT							
	Rated input current (A)	1-phase	2.5	3.0	5.0	10.4	-	-	-
		3-phase	1.5	1.8	3.0	5.0	7.0	11.0	12.0
	Power supply capacity (kVA)	1-phase	0.5	0.7	1.2	2.0	-	-	-
3-phase		0.5	0.7	1.1	1.9	2.7	4.2	4.6	
Inrush current (A)		8.0							
24 VDC power supply	Voltage (V)	24 (-15% to +20%) ²⁾							
	Maximum current (A)	When using a motor without a brake: 1.6 A When using a motor with a brake: 1.6 A + motor holding brake rated current (See Section "Technical data - servo motors (Page 60)".)							
Cooling method		Self-cooled				Fan-cooled			
Mechanical design	Outline dimensions (W x H x D, mm)	45 x 170 x 170		55 x 170 x 170	80 x 170 x 195	95 x 170 x 195			
		1.1		1.25	1.95	2.3	2.4		

- 1) The values here are calculated at rated load.
- 2) When SINAMICS V90 PN works with a motor with a brake, the voltage tolerance of 24 VDC power supply must be -10% to +10% to meet the voltage requirement of the brake.

2.6.1.2 SINAMICS V90 PN 400 V variant

General technical data

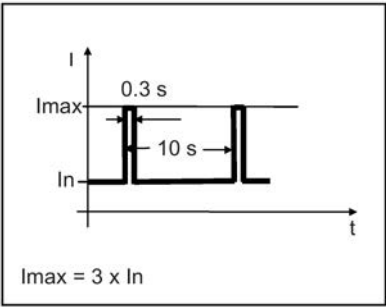
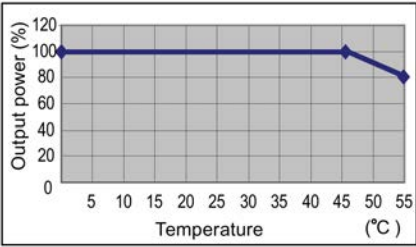
Parameter		Description		
Overload capability		300% 		
Control system		Servo control		
Dynamic brake		Built-in		
Protective functions		Earthing fault protection, output short-circuit protection ¹⁾ , overvoltage/undervoltage protection ²⁾ , I ² t inverter, I ² t motor, IGBT overtemperature protection ³⁾		
Overvoltage criteria		Category III		
Speed control mode	Speed control range	Internal speed command 1:5000		
	Torque limit	Set through a parameter		
Environmental conditions	Surrounding air temperature	Operation	0 °C to 45 °C: without power derating 45 °C to 55 °C: with power derating	
				
	Storage	-40 °C to +70 °C		
	Ambient humidity	Operation	< 90% (non-condensing)	
		Storage	90% (non-condensing)	
Operating environment		Indoors (without direct sunlight), free from corrosive gas, combustible gas, oil gas, or dust		

Parameter		Description															
	Altitude	≤ 1000 m (without power derating) <table border="1"> <caption>Output power (%) vs Altitude (m)</caption> <thead> <tr> <th>Altitude (m)</th> <th>Output power (%)</th> </tr> </thead> <tbody> <tr> <td>0</td> <td>100</td> </tr> <tr> <td>1000</td> <td>95</td> </tr> <tr> <td>2000</td> <td>80</td> </tr> <tr> <td>3000</td> <td>75</td> </tr> <tr> <td>4000</td> <td>65</td> </tr> <tr> <td>5000</td> <td>60</td> </tr> </tbody> </table>		Altitude (m)	Output power (%)	0	100	1000	95	2000	80	3000	75	4000	65	5000	60
	Altitude (m)	Output power (%)															
	0	100															
1000	95																
2000	80																
3000	75																
4000	65																
5000	60																
Degree of protection	IP 20																
Degree of pollution	Class 2																
Vibration	Operation	Shock	Operational area II Peak acceleration: 5 g, 30 ms and 15 g, 11 ms Quantity of shocks: 3 per direction × 6 directions Duration of shock: 1 s														
		Vibration	Operational area II 10 Hz to 58 Hz: 0.075 mm deflection 58 Hz to 200 Hz: 1 g vibration														
	Product packaging	Vibration	2 Hz to 9 Hz: 3.5 mm deflection 9 Hz to 200 Hz: 1 g vibration Quantity of cycles: 10 per axis Sweep seed: 1 octave/min														
Certification																	

- 1) Integral solid state short circuit protection does not provide branch circuit protection. Branch circuit protection must be provided in accordance with the National Electrical Code and any additional local codes.
- 2) The V90 PN 200 V servo drive has an overvoltage threshold of 410 VDC and an undervoltage threshold of 150 VDC; the V90 PN 400 V servo drive has an overvoltage threshold of 820 VDC and an undervoltage threshold of 320 VDC.
- 3) SINAMICS V90 PN does not support motor overtemperature protection. Motor overtemperature is calculated by I^2t and protected by the output current from the drive.

Specific technical data

Article No.	6SL3210-5FE...	10-4UF0	10-8UF0	11-0UF0	11-5UF0	12-0UF0	13-5UF0	15-0UF0	17-0UF0
Frame size		FSAA	FSA	FSA	FSB	FSB	FSC	FSC	FSC
Rated output current (A)		1.2	2.1	3.0	5.3	7.8	11.0	12.6	13.2
Max. output current (A)		3.6	6.3	9.0	13.8	23.4	33.0	37.8	39.6
Max. supported motor power (kW)		0.4	0.75	1.0	1.75	2.5	3.5	5.0	7.0
Power loss ¹⁾	Main circuit (W)	12	29	32	84	96	92	115	138
	Regenerative resistor (W)	17	57	57	131	131	339	339	339
	Control circuit (W)	32	32	35	35	35	36	36	36
	Total (W)	61	118	124	250	262	467	490	513
Output frequency (Hz)		0 to 330							
Power supply	Voltage/frequency	Three phase 380 VAC to 480 VAC, 50/60 Hz							
	Permissible voltage fluctuation	-15% to +10%							
	Permissible frequency fluctuation	-10% to +10%							
	Permissible supply configuration	TN, TT, IT							
	Rated input current (A)	1.5	2.6	3.8	6.6	9.8	13.8	15.8	16.5
	Power supply capacity (kVA)	1.7	3.0	4.3	7.6	11.1	15.7	18.0	18.9
	Inrush current (A)	8.0	8.0	8.0	4.0	4.0	2.5	2.5	2.5
24 VDC power supply	Voltage (V)	24 (-15% to +20%) ²⁾							
	Maximum current (A)	When using a motor without a brake: 1.6 A When using a motor with a brake: 1.6 A + motor holding brake rated current (See Section "Technical data - servo motors (Page 64)".)							
Cooling method		Self-cooled			Fan-cooled				
Mechanical design	Outline dimensions (W x H x D, mm)	60 x 180 x 200	80 x 180 x 200		100 x 180 x 220		140 x 260 x 240		
Weight (kg)		1.5	1.9	1.9	2.5	2.5	5.0	5.5	5.75



1) The values here are calculated at rated load.

2) When SINAMICS V90 PN works with a motor with a brake, the voltage tolerance of 24 VDC power supply must be -10% to +10% to meet the voltage requirement of the brake.

2.6.2 Technical data - servo motors

2.6.2.1 1FL6 servo motor - low inertia

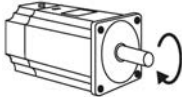
General technical data

Parameter	Description
Type of motor	Permanent-magnet synchronous motor
Cooling	Self-cooled
Relative humidity [RH]	90% (non-condensing at 30°C)
Installation altitude [m]	≤ 1000 (without power derating)
Thermal class	B
Vibration severity grade	A (according to IEC 60034-14)
Shock resistance [m/s ²]	25 (continuous in axial direction); 50 (continuous in radial direction); 250 (in a short time of 6 ms)
Bearing lifetime [h]	> 20000 ¹⁾
Paint finish	Black
Protection degree of shaft	IP 65, with shaft oil seal
Type of construction	IM B5, IM V1, and IM V3
Positive rotation	Clockwise (default setting in servo drives) 
Certification	

¹⁾ This lifetime is only for reference. When a motor keeps running at rated speed under rated load, replace its bearing after 20,000 to 30,000 hours of service time. Even if the time is not reached, the bearing must be replaced when unusual noise, vibration, or faults are found.

Specific technical data

Article No.	1FL60...	22	24	32	34	42	44	52	54
Rated power [kW]		0.05	0.1	0.2	0.4	0.75	1	1.5	2
Rated torque [Nm]		0.16	0.32	0.64	1.27	2.39	3.18	4.78	6.37
Maximum torque [Nm]		0.48	0.96	1.91	3.82	7.2	9.54	14.3	19.1
Rated speed [rpm]		3000							
Maximum speed [rpm]		5000							
Rated frequency [Hz]		200							
Rated current [A]		1.2	1.2	1.4	2.6	4.7	6.3	10.6	11.6
Maximum current [A]		3.6	3.6	4.2	7.8	14.2	18.9	31.8	34.8
Moment of inertia [10 ⁻⁴ kgm ²]		0.031	0.052	0.214	0.351	0.897	1.15	2.04	2.62

Article No.	1FL60...	22	24	32	34	42	44	52	54
Moment of inertia (with brake) [10^{-4} kgm ²]		0.038	0.059	0.245	0.381	1.06	1.31	2.24	2.82
Recommended load to motor inertia ratio		Max. 30x				Max. 20x		Max. 15x	
Operating temperature [°C]		1FL602□, 1FL603□ and 1FL604□: 0 to 40 (without power derating) 1FL605□: 0 to 30 (without power derating) ¹⁾							
Storage temperature [°C]		-20 to +65							
Maximum noise level [dB]		60							
Holding brake	Rated voltage (V)	24 ± 10%							
	Rated current (A)	0.25		0.3		0.35		0.57	
	Holding brake torque [Nm]	0.32		1.27		3.18		6.37	
	Maximum brake opening time [ms]	35		75		105		90	
	Maximum brake closing time [ms]	10		10		15		35	
	Maximum number of emergency stops	2000 ²⁾							
Oil seal lifetime [h]		3000 to 5000							
Encoder lifetime [h]		> 20000 ³⁾							
Protection degree of motor body		IP 65							
Protection degree of cable end connector		IP20						-	
Weight [kg]	With brake	0.7	0.9	1.5	1.9	3.7	4.2	6.8/7.0 ⁴⁾	8.0/8.2 ⁴⁾
	Without brake	0.5	0.6	1.0	1.5	2.8	3.4	5.4/5.5 ⁴⁾	6.6/6.7 ⁴⁾

- 1) When the surrounding temperature is between 30 °C and 40 °C, the 1FL605 motor will have a power derating of 10%.
- 2) Restricted emergency stop operation is permissible. Up to 2000 braking operations for the motors of 0.05 kW to 1 kW, and 200 braking operations for the motors of 1.5 kW to 2 kW can be executed with 300% rotor moment of inertia as external moment of inertia from a speed of 3000 rpm without the brake being subject to an inadmissible amount of wear.
- 3) This lifetime is only for reference. When a motor keeps running at 80% rated value and the surrounding temperature is 30 °C, the encoder lifetime can be ensured.
- 4) The former value indicates the data for low inertia motors with straight connectors; the later value indicates the data for low inertia motors with angular connectors.

Note

The data of rated torque, rated power, maximum torque, and armature resistance in the above table allows a tolerance of 10%.

Torque-Speed characteristics

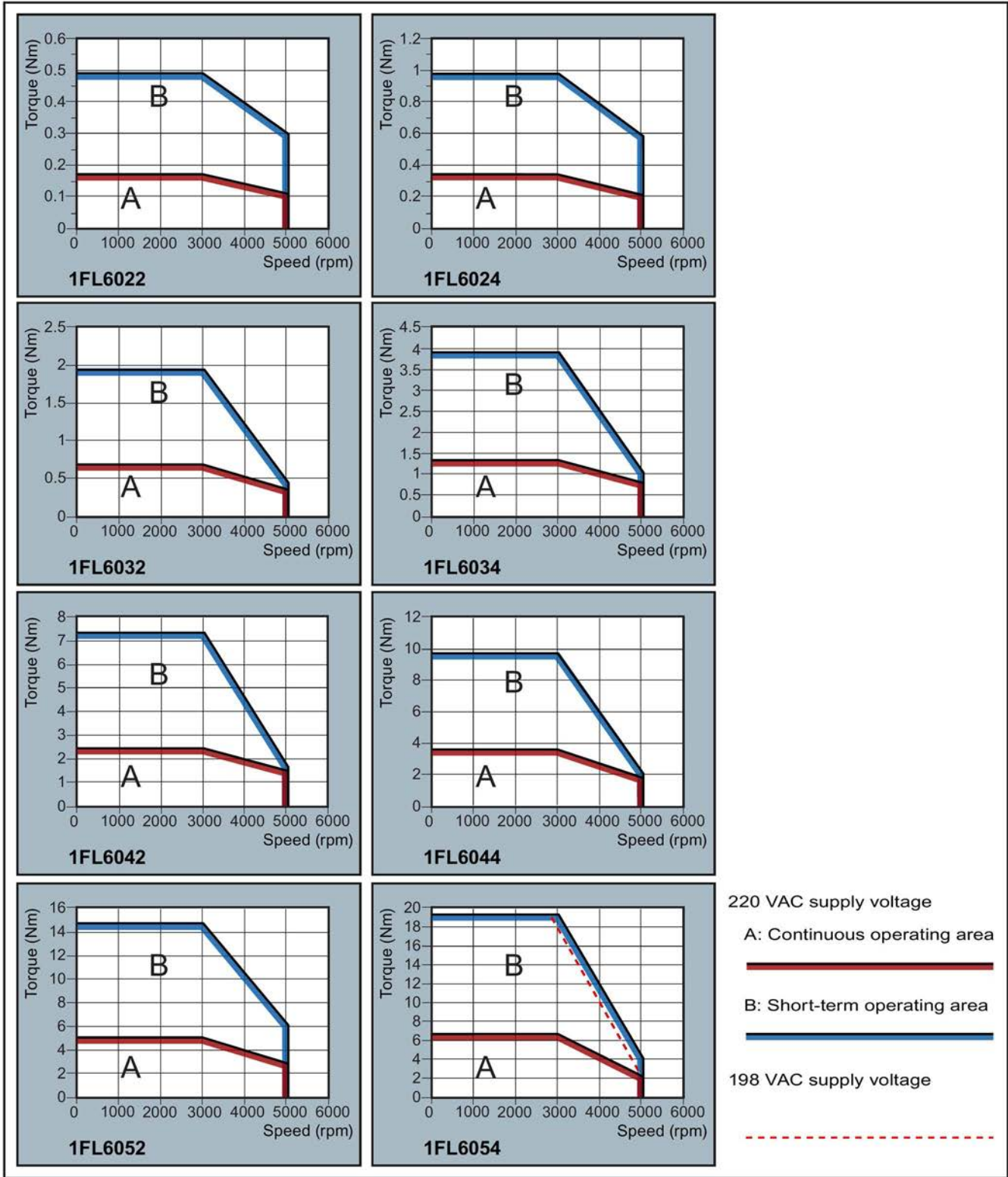

Note

- Continuous operating area is a series of states when a motor can operate continuously and safely. The effective torque must be located in this area.
- Short-term operating area is a series of states when a motor can operate for a short duration if its effective torque is larger than the rated torque.
- For the motors with different rated and maximum speeds, the output torque will decline at a faster rate after the speed exceeds the rated speed.
- The feature in short-term operating area varies with power supply voltages.
- The continuous operating area becomes smaller and the voltage consumptions on the cables grow larger when the cables in the major loop exceed 20 m.

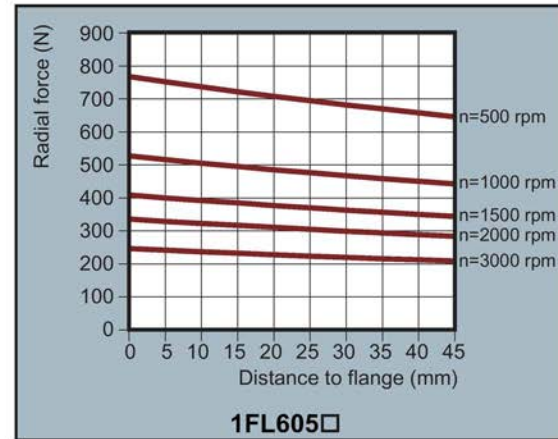
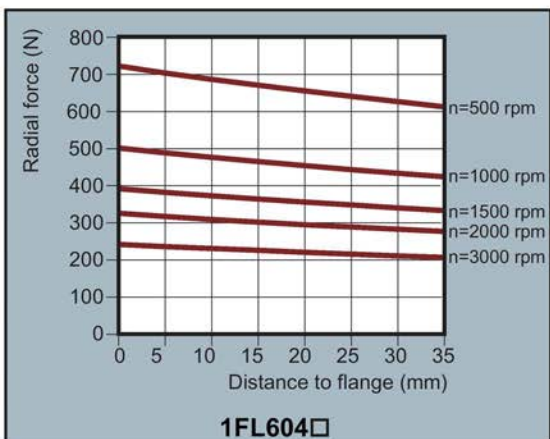
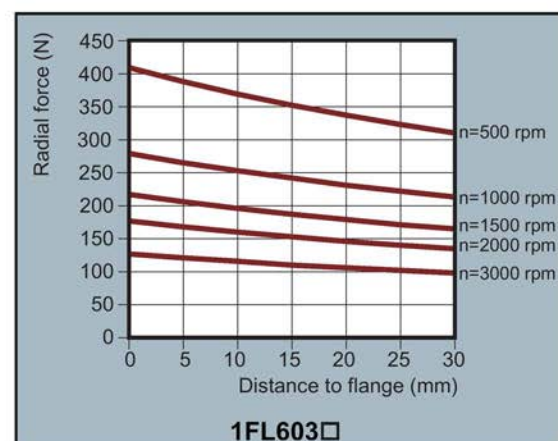
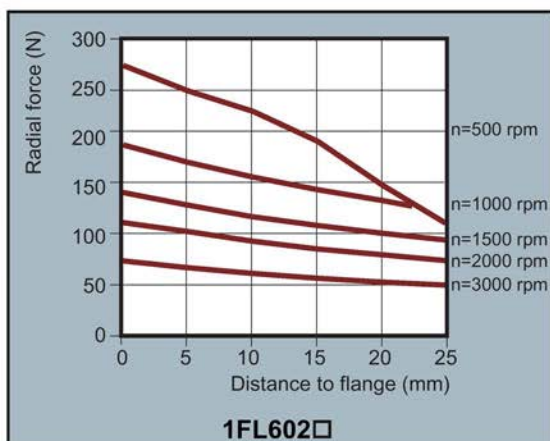
Permissible radial and axial forces**Axial force:**

When using, for example, helical toothed wheels as drive element, in addition to the radial force, there is also an axial force on the motor bearings. For axial forces, the spring-loading of the bearings can be overcome so that the rotor moves corresponding to the axial bearing present (up to 0.2 mm).



The permissible axial force can be approximately calculated using the following formula:

$$F_A = 0.35 \cdot F_Q$$

Where F_A represents axial force and F_Q radial force.

2.6.2.2 1FL6 servo motor - high inertia

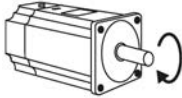
General technical data

Parameter	Description
Type of motor	Permanent-magnet synchronous motor
Cooling	Self-cooled
Relative humidity [RH]	90% (non-condensing at 30°C)
Installation altitude [m]	≤ 1000 (without power derating)
Thermal class	B
Vibration severity grade	A (according to IEC 60034-14)
Shock resistance [m/s ²]	25 (continuous in axial direction); 50 (continuous in radial direction); 250 (in a short time of 6 ms)
Bearing lifetime [h]	> 20000 ¹⁾
Paint finish	Black
Protection degree of shaft	IP 65, with shaft oil seal
Type of construction	IM B5, IM V1, and IM V3
Positive rotation	Clockwise (default setting in servo drives) 
Certification	

¹⁾ This lifetime is only for reference. When a motor keeps running at rated speed under rated load, replace its bearing after 20,000 to 30,000 hours of service time. Even if the time is not reached, the bearing must be replaced when unusual noise, vibration, or faults are found.

Specific technical data

Article No.	1FL60...	42	44	61	62	64	66	67	90	92	94	96
Rated power [kW]		0.40	0.75	0.75	1.00	1.50	1.75	2.00	2.5	3.5	5.0	7.0 ¹⁾
Rated torque [Nm]		1.27	2.39	3.58	4.78	7.16	8.36	9.55	11.9	16.7	23.9	33.4
Maximum torque [Nm]		3.8	7.2	10.7	14.3	21.5	25.1	28.7	35.7	50.0	70.0	90.0
Rated speed [rpm]		3000		2000				2000				
Maximum speed [rpm]		4000		3000				3000		2500	2000	
Rated frequency [Hz]		200		133				133				
Rated current [A]		1.2	2.1	2.5	3.0	4.6	5.3	5.9	7.8	11.0	12.6	13.2
Maximum current [A]		3.6	6.3	7.5	9.0	13.8	15.9	17.7	23.4	33.0	36.9	35.6
Moment of inertia [10 ⁻⁴ kgm ²]		2.7	5.2	8.0	15.3/1.7 ²⁾	15.3	22.6	29.9	47.4	69.1	90.8	134.3
Moment of inertia (with brake) [10 ⁻⁴ kgm ²]		3.2	5.7	9.1	16.4/1.35 ²⁾	16.4	23.7	31.0	56.3	77.9	99.7	143.2

Article No.	1FL60...	42	44	61	62	64	66	67	90	92	94	96
Recommended load to motor inertia ratio		Max. 10×		Max. 5×					Max. 5×			
Operating temperature [°C]		0 to 40 (without power derating)										
Storage temperature [°C]		-20 to +65										
Maximum noise level [dB]		65		70					70			
Holding brake	Rated voltage (V)	24 ± 10%										
	Rated current (A)	0.88		1.44					1.88			
	Holding brake torque [Nm]	3.5		12					30			
	Maximum brake opening time [ms]	60		180					220			
	Maximum brake closing time [ms]	45		60					115			
	Maximum number of emergency stops	2000 ³⁾										
Oil seal lifetime [h]		5000										
Encoder lifetime [h]		> 20000 ⁴⁾										
Degree of protection		IP65, with shaft oil seal										
Weight of incremental encoder motor [kg]	With brake ²⁾	4.6/4.8	6.4/6.6	8.6/8.8	11.3/10.1	11.3/11.5	14.0/14.2	16.6/16.8	21.3/21.5	25.7/25.9	30.3/30.5	39.1/39.3
	Without brake ²⁾	3.3/3.4	5.1/5.2	5.6/5.7	8.3/7.0	8.3/8.4	11.0/11.1	13.6/13.7	15.3/15.4	19.7/19.8	24.3/24.4	33.2/33.3
Weight of absolute encoder motor [kg]	With brake ²⁾	4.4/4.5	6.2/6.3	8.3/8.4	11.0/10.7	11.0/11.1	13.6/13.7	16.3/16.4	20.9/21.0	25.3/25.4	29.9/30.0	38.7/38.8
	Without brake ²⁾	3.1/3.2	4.9/5.0	5.3/5.4	8.0/7.7	8.0/8.1	10.7/10.8	13.3/13.4	14.8/14.9	19.3/19.4	23.9/24.0	32.7/32.8

- 1) When the surrounding temperature is between 30 °C and 40 °C, the 1FL6096 motors with brake will have a power derating of 10%.
- 2) The former value indicates the data for high inertia motors with straight connectors; the latter value indicates the data for high inertia motors with angular connectors.
- 3) Restricted emergency stop operation is permissible. Up to 2000 braking operations can be executed with 300% rotor moment of inertia as external moment of inertia from a speed of 3000 rpm without the brake being subject to an inadmissible amount of wear.
- 4) This lifetime is only for reference. When a motor keeps running at 80% rated value and the surrounding temperature is 30 °C, the encoder lifetime can be ensured.

Note

The data of rated torque, rated power, and maximum torque in the above table allows a tolerance of 10%.

Torque-Speed characteristics

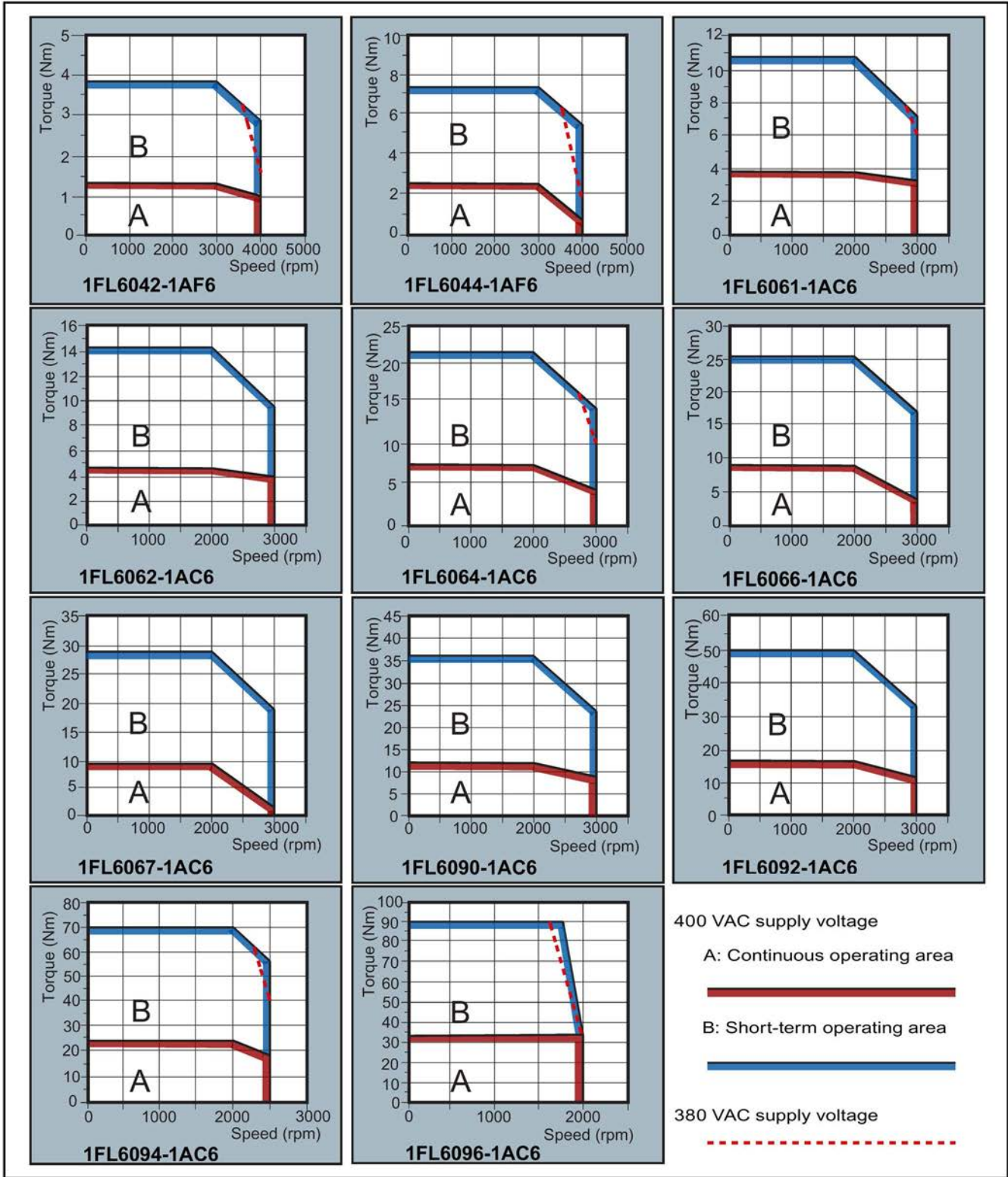

Note

- Continuous operating area is a series of states when a motor can operate continuously and safely. The effective torque must be located in this area.
- Short-term operating area is a series of states when a motor can operate for a short duration if its effective torque is larger than the rated torque.
- For the motors with different rated and maximum speeds, the output torque will decline at a faster rate after the speed exceeds the rated speed.
- The feature in short-term operating area varies with power supply voltages.
- The continuous operating area becomes smaller and the voltage consumptions grows larger when the cables in the major loop exceed 20 meters.
- For 1FL6096 motors, the maximum speed can be ensured when the line supply voltage is higher than 380V.

Permissible radial and axial forces

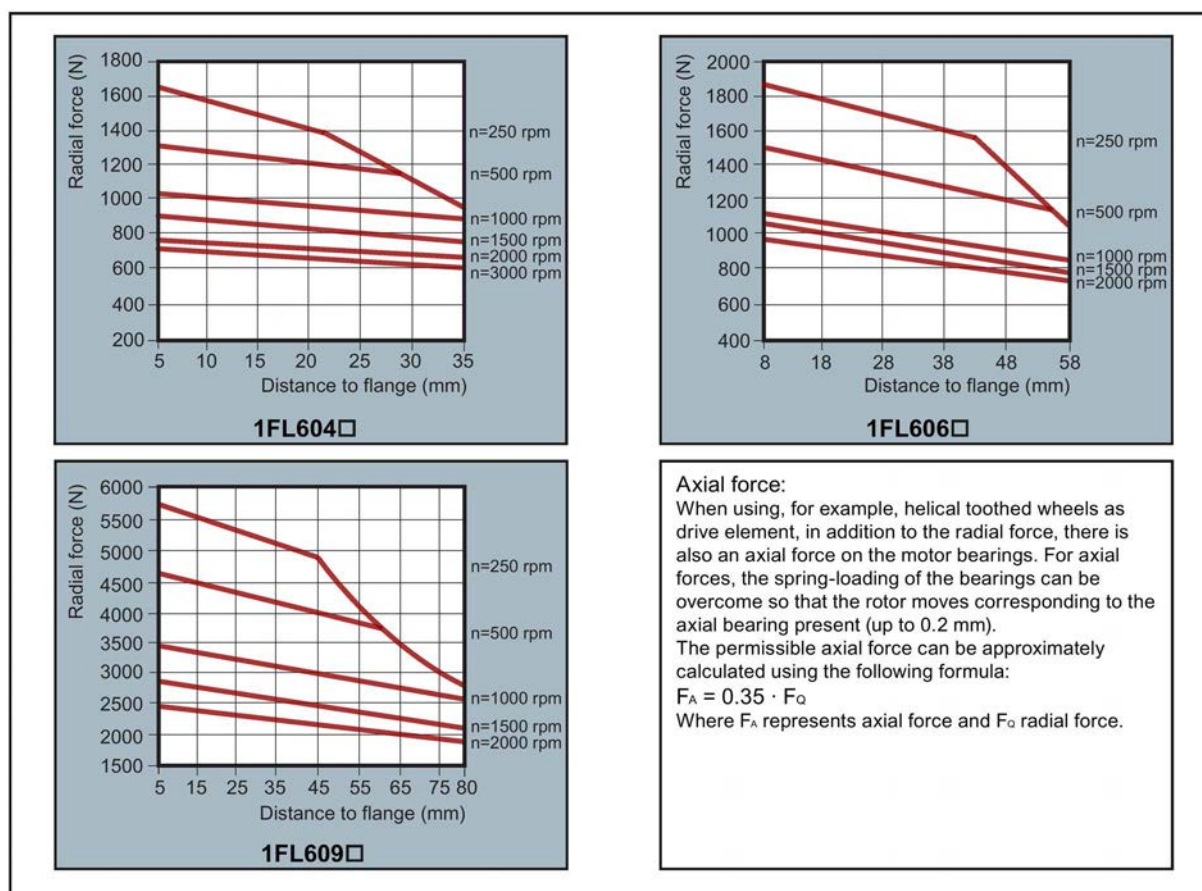

Note

1FL604□ and 1FL609□ have a 5 mm of shaft sheltered in sleeves, and 1FL606□ has an 8 mm of shaft in sleeves. Therefore, the distances to flange in the above three figures begin respectively from 5 mm, 8mm, and 5 mm.

2.6.2.3 Power derating

For deviating conditions (surrounding temperature > 40 °C or installation altitude > 1000 m above sea level) the permissible torque/power must be determined from the following table. Surrounding temperatures and installation altitudes are rounded off to 5 °C and 500 m respectively.

Power derating as a function of the installation altitude and ambient temperature

Installation altitude above sea level (m)	Surrounding temperature in °C				
	< 30	30 to 40	45	50	55
1000	1.07	1.00	0.96	0.92	0.87
1500	1.04	0.97	0.93	0.89	0.84
2000	1.00	0.94	0.90	0.86	0.82
2500	0.96	0.90	0.86	0.83	0.78
3000	0.92	0.86	0.82	0.79	0.75
3500	0.88	0.82	0.79	0.75	0.71
4000	0.82	0.77	0.74	0.71	0.67

2.6.3 Technical data - cables

Parameter	MOTION-CONNECT 300 Power Cable	MOTION-CONNECT 300 Encoder Cable	MOTION-CONNECT 300 Brake Cable
General technical data			
Jacket material	PVC	PVC	PVC
Number of cores	4	10	2
Operation temperature (°C)	-25 to 80		
Shielding	Yes <ul style="list-style-type: none"> • Coverage ≥ 60%: For 200 V variant servo drives + low inertia motors of 0.05 kW to 1 kW • Coverage ≥ 85%: For 200 V variant servo drives + low inertia motors of 1.5 kW to 2 kW, and for 400 V variant servo drives + high inertia motors of 0.4 kW to 7 kW 		
Minimum bending radius, static (mm)	5 x outer diameter		
Minimum bending radius, dynamic (mm)	155		
Oil resistance	EN60811-2-1 fulfilled		
Flame-retardant	EN60332-1-1 to 1-3 fulfilled		
Certification	RoHS, CE	RoHS	RoHS
Specific technical data			
Cable used for 200 V variant servo drive + low inertia motor of 0.05 kW to 1 kW			
Rated voltage (V)	300/500	30	30

Parameter	MOTION-CONNECT 300 Power Cable	MOTION-CONNECT 300 Encoder Cable	MOTION-CONNECT 300 Brake Cable
Cross-section of cores (mm ²)	4 x 0.75	3 x 2 x 0.20 + 4 x 0.25	2 x 0.75
Outer diameter (mm)	∅ (6.7±0.4)	∅ (7.2±0.3)	∅ (6.1±0.3)
Degree of protection (motor-side only)	IP20		
Bending cycles	100000: Maximum acceleration 3 m/s ² , maximum speed 40 m/min		
Cable used for 200 V variant servo drives + low inertia motors of 1.5 kW to 2 kW, and for 400 V variant servo drives + high inertia motors of 0.4 kW to 7 kW			
Cross-section of cores (mm ²)	<ul style="list-style-type: none"> • 4 x 1.5: For high inertia motors of 0.4 kW to 1 kW • 4 x 2.5: For low inertia motors of 1.5 kW to 2 kW and high inertia motors of 1.5 kW to 7 kW 	3 x 2 x 0.22 + 4 x 0.25	2 x 0.75
Rated voltage (V)	600/1000	30	30
Outer diameter (mm)	<ul style="list-style-type: none"> • ∅ (7.8±0.3): For high inertia motors of 0.4 kW to 1 kW • ∅ (9.0±0.4): For low inertia motors of 1.5 kW to 2 kW and high inertia motors of 1.5 kW to 7 kW 	∅ (6.9±0.3)	∅ (6.0±0.3)
Degree of protection (motor-side only)	IP65		
Bending cycles	1000000: Maximum acceleration 3 m/s ² , maximum speed 40 m/min		

2.6.4 Address of CE-authorized manufacturer

The CE Declaration of Conformity is held on file available to the competent authorities at the following address:

SINAMICS V90 drive

Siemens AG
Digital Factory
Motion Control
Frauenauracher Straße 80
DE-91056 Erlangen
Germany

SIMOTICS S-1FL6 motor

Siemens AG
Digital Factory
Motion Control
Industriestraße 1
DE-97615 Bad Neustadt a. d. Saale
Germany

Mounting

3.1 Mounting the drive

Protection against the spread of fire

The device may be operated only in closed housings or in control cabinets with protective covers that are closed, and when all of the protective devices are used. The installation of the device in a metal control cabinet or the protection with another equivalent measure must prevent the spread of fire and emissions outside the control cabinet.

Protection against condensation or electrically conductive contamination

Protect the device, e.g. by installing it in a control cabinet with degree of protection IP54 according to IEC 60529 or NEMA 12. Further measures may be necessary for particularly critical operating conditions.

If condensation or conductive pollution can be excluded at the installation site, a lower degree of control cabinet protection may be permitted.

WARNING

Death or severe personal injury from harsh installation environment

A harsh installation environment will jeopardize personal safety and equipment. Therefore,

- Do not install the drive and the motor in an area subject to inflammables or combustibles, water or corrosion hazards.
- Do not install the drive and the motor in an area where it is likely to be exposed to constant vibrations or physical shocks.
- Do not keep the drive exposed to strong electro-magnetic interference.



CAUTION

Risk of injury due to touching hot surfaces

There is a risk of injury if you touch the hot surfaces, because surfaces of the drive can reach a high temperature during operation and for a short time after switching-off.

- Avoid coming into direct contact with the drive surface.

For mounting conditions, see Technical data - servo drives (Page 54).

3.1.1 Mounting orientation and clearance

The SINAMICS V90 PN 200 V variant servo drives with rated power of 400 W and 750 W support vertical mounting and horizontal mounting. Other drives support vertical mounting only.

Mount the drive in a shielded cabinet by observing the mounting orientation and clearance specified in the following illustrations.

Mounting orientation

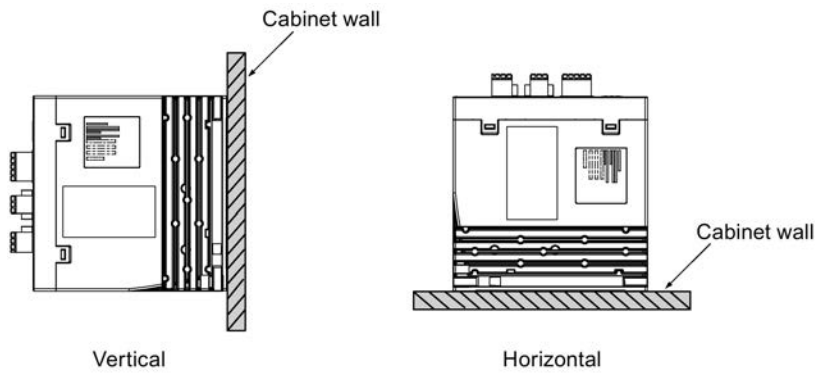

Mounting clearance

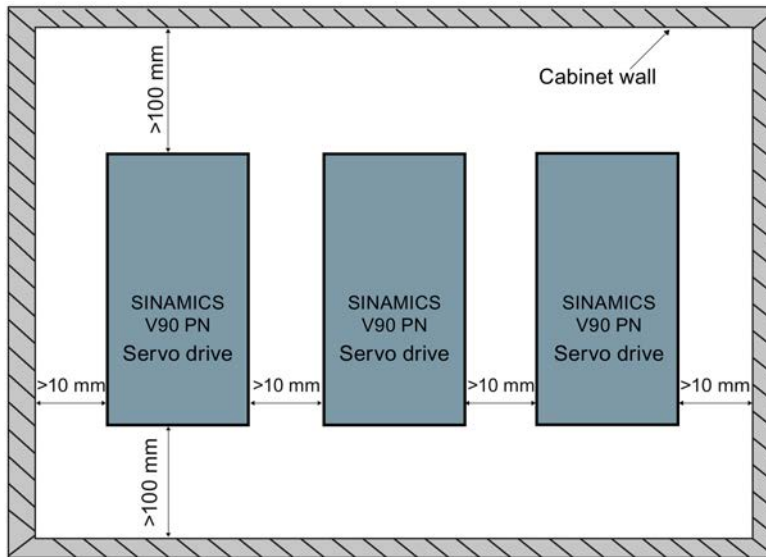

Note

When mounting the drive horizontally, you need to make sure the distance between the drive front panel and the top cabinet wall is larger than 100 mm.

Note

The drive must be derated to 80% when one of the following conditions is satisfied:

- The surrounding temperature is 0 °C to 45 °C, and the mounting clearance is less than 10 mm. In this case, the minimum mounting clearance should not be less than 5 mm.
- The surrounding temperature is 45 °C to 55 °C. In this case, the minimum mounting clearance should not be less than 20 mm.

3.1.2 Drill patterns and outline dimensions

SINAMICS V90 PN 200V variant (unit: mm)

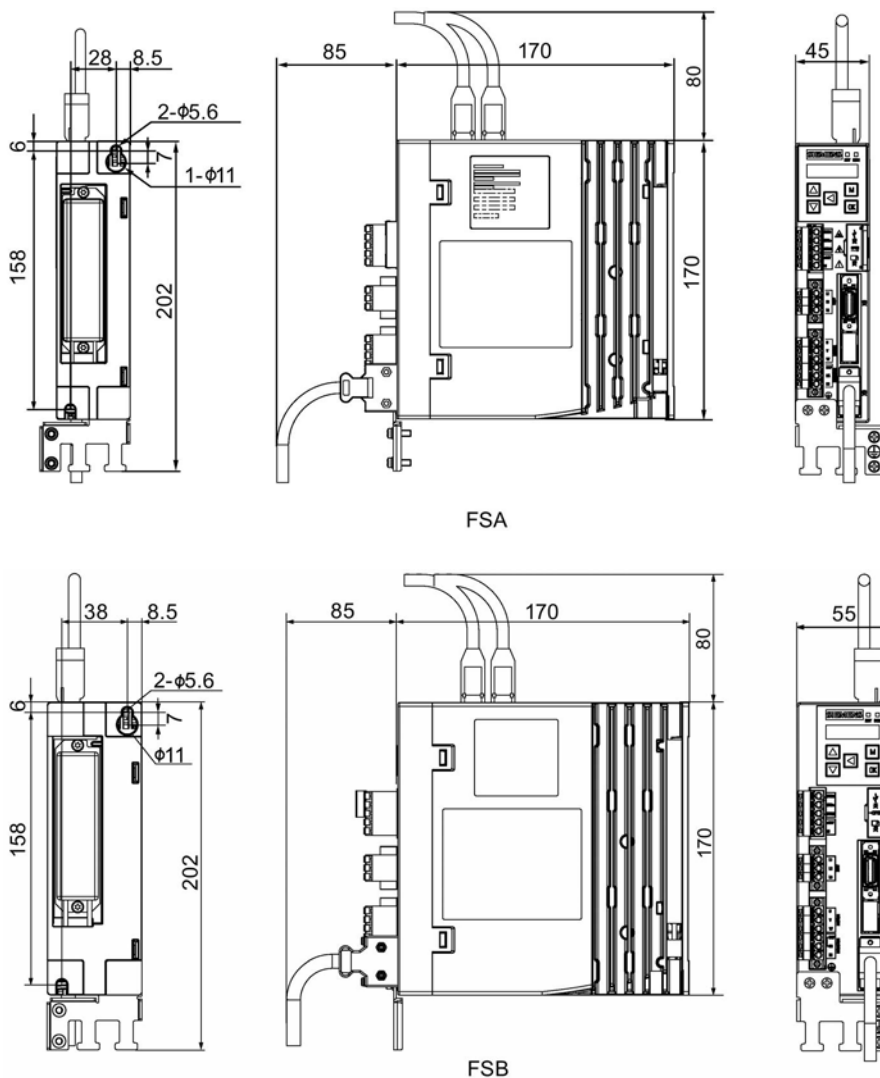

Mounting

3.1 Mounting the drive

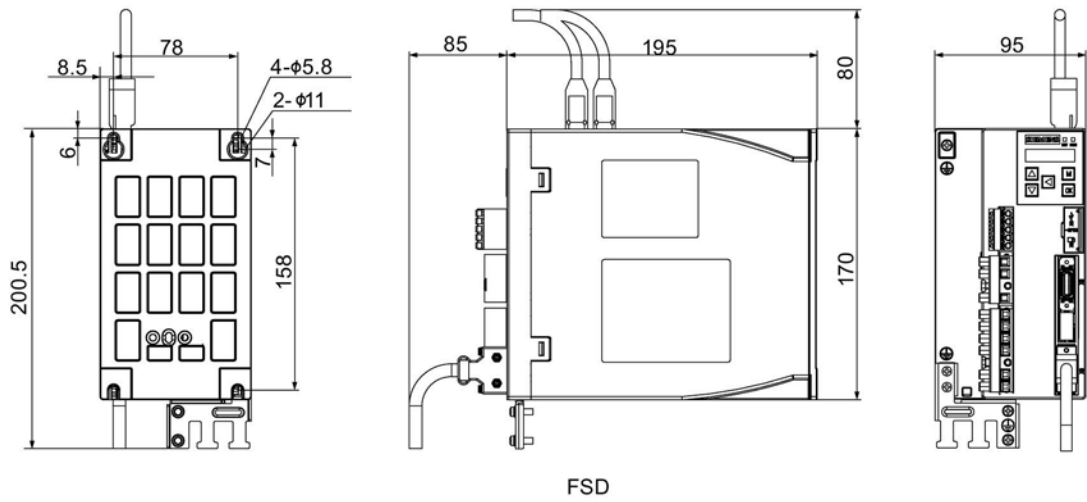
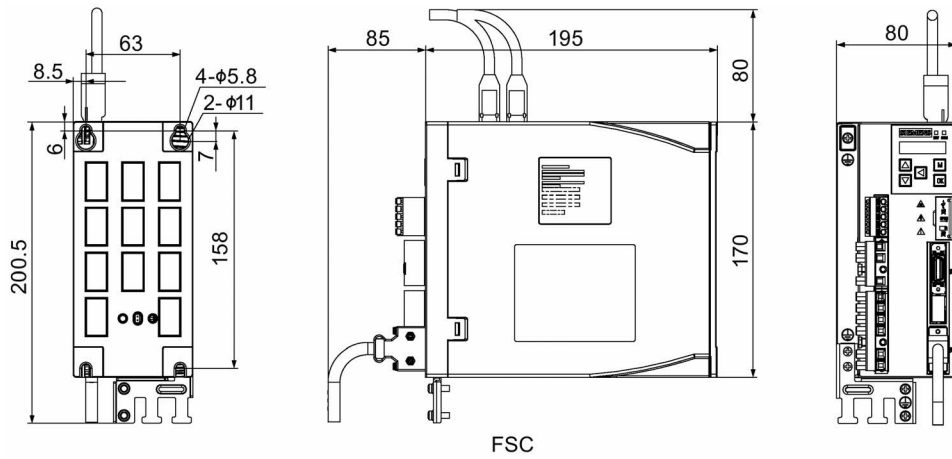

SINAMICS V90 PN 400V variant (unit: mm)

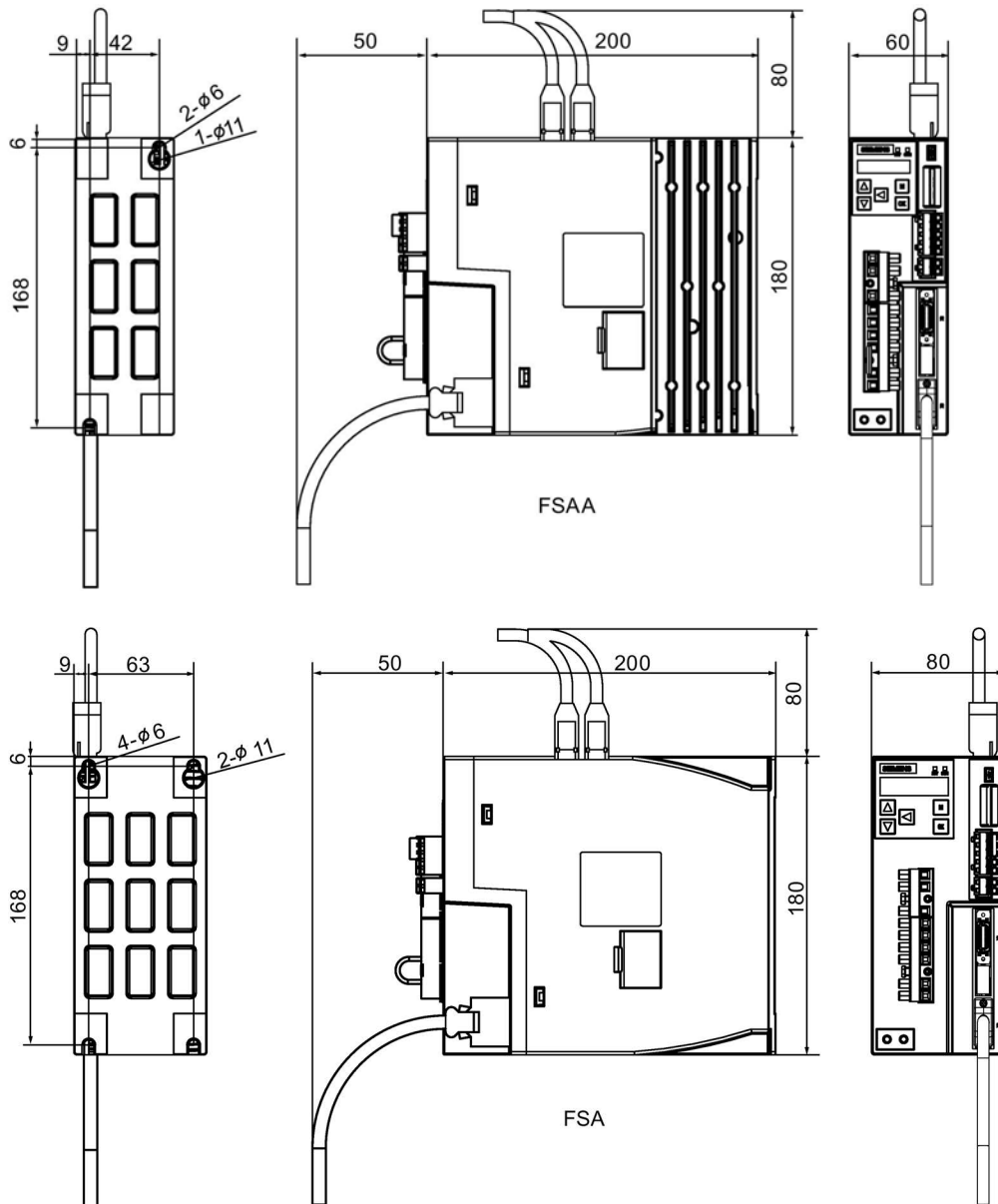

Mounting

3.1 Mounting the drive

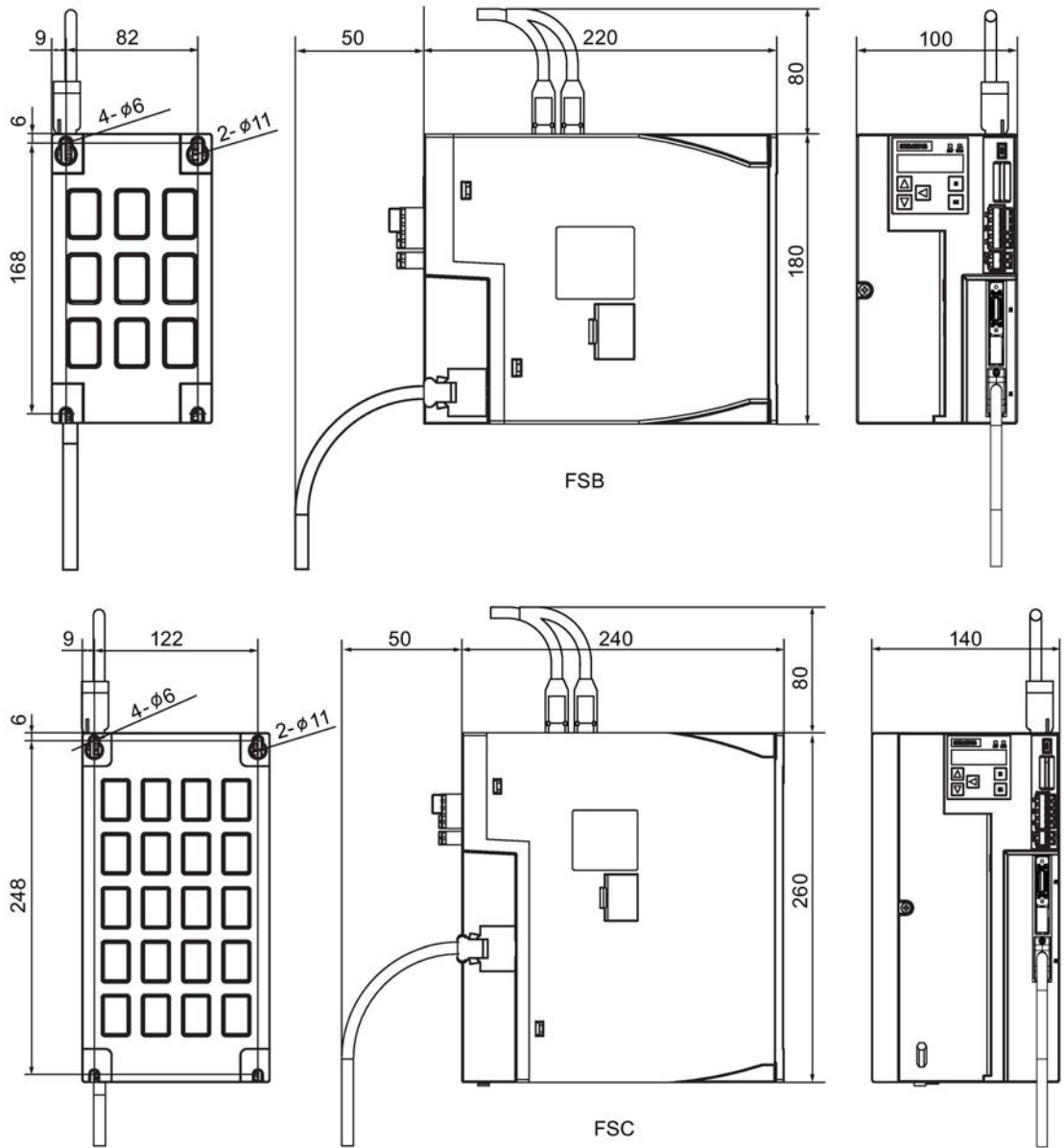

3.1.3 Mounting the drive

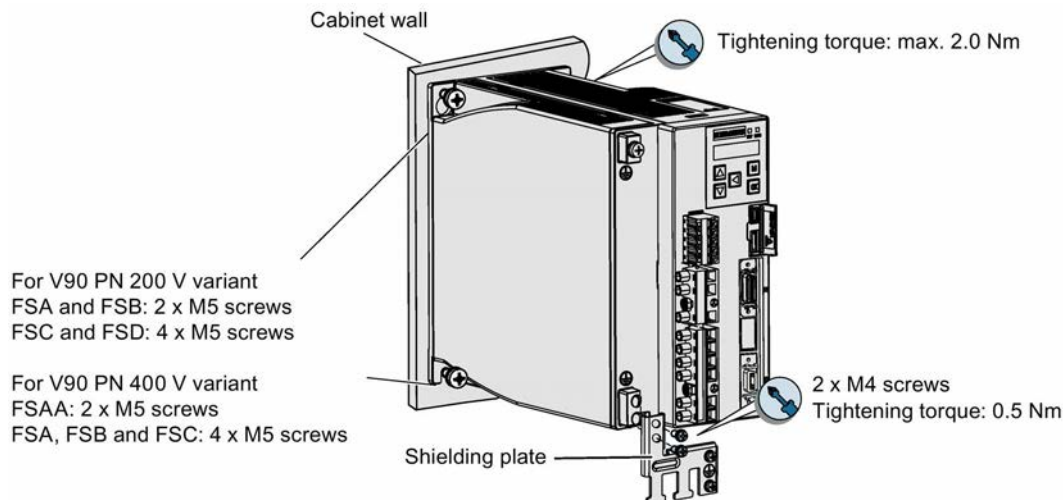

Note

EMC instructions

- To comply with the EMC standards, all cables connected with the SINAMICS V90 PN drive system must be shielded cables, which include cables from the line supply to the line filter and from the line filter to the drive.
- Route signal cables and power cables separately in different cable conduits. The signal cables shall be at least 10 cm away from the power cables.
- The SINAMICS V90 PN drives have been tested in accordance with the emission requirements of the category of C2 (domestic) environment. The conductive emissions and radiated emissions are in compliance with the standard of EN 55011 and reached Class A.
- In a residential environment, this product can cause high-frequency interferences that may necessitate suppression measures.
- For a radiated emission test, an external AC filter (between the mains supply and the drive) will be used to meet the EMC requirement and the drive will be installed inside the shielded metallic chamber, other parts of the motion control system (including the PLC, DC power supply, motor) will be put inside the shielded chamber.
- For a conductive emission test, an external AC filter (between the mains supply and the drive) will be used to meet the EMC requirement.
- For the radiated emission and conductive emission test, the length of the line supply cable between the line filter and the drive must be shorter than 1 m.
- The harmonic current value of SINAMICS V90 PN drive exceeds the class A limit of IEC 61000-3-2, but the SINAMICS V90 PN drive system installed within the Category C2 First Environment require supply authority acceptance for connection to the public low-voltage power supply network. Please contact your local supply network provider.

Note

Screw tightening

Make sure you fix the screw to the terminal door of the drive after you have completed the installation work.

3.2 Mounting the motor

NOTICE

Damage to the encoder due to shocking

Shocks at the motor shaft end can cause an encoder damage.



- Do not exert any shock at the shaft end.

For mounting conditions, see Technical data - servo motors (Page 60).

3.2.1 Mounting orientation and dimensions

Mounting orientation

SIMOTICS S-1FL6 supports flange mounting only and three types of constructions, so it can be installed in three orientations as shown in the following figure.

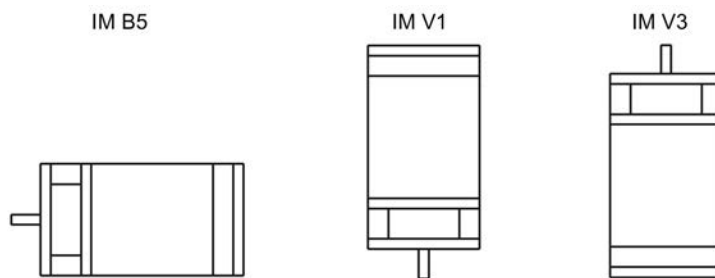

Note

When configuring the IM V3 type of construction, you need to pay particular attention to the permissible axial force (weight force of the drive elements) and the necessary degree of protection.

SIMOTICS S-1FL6 Low inertia servo motors (unit: mm)

Shaft height 20 mm

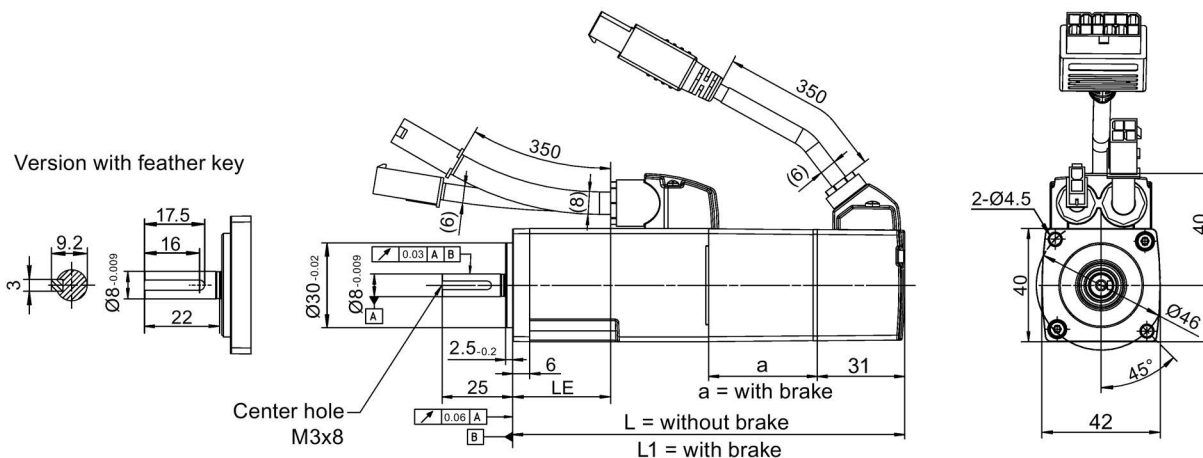

Rated power	Rated torque	a	L	L1	LE
0.05 kW	0.16 Nm	38.5	86	119	15
0.1 kW	0.32 Nm	38.5	106	139	35

Shaft height 30 mm

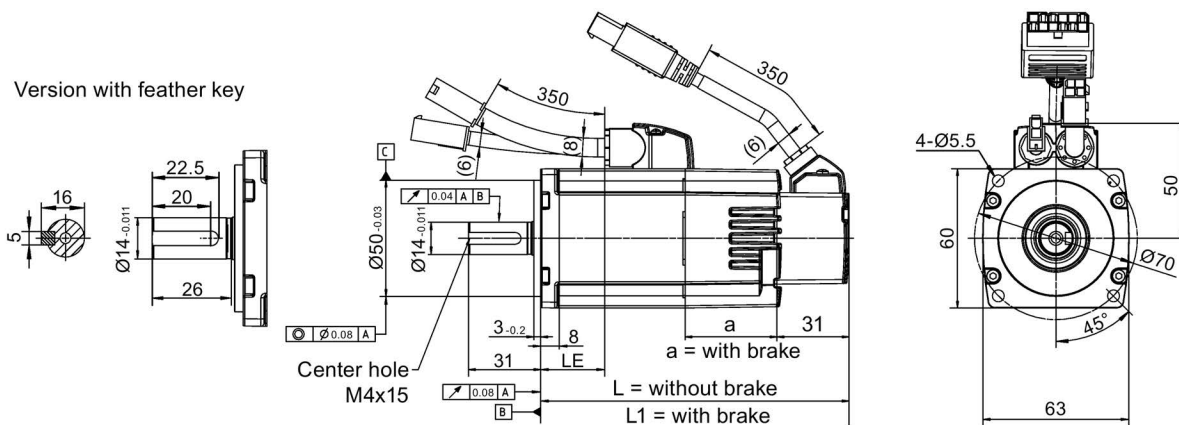

Rated power	Rated torque	a	L	L1	LE
0.2 kW	0.64 Nm	39.5	98	132.5	27
0.4 kW	1.27 Nm	39.5	123	157.5	52

Shaft height 40 mm

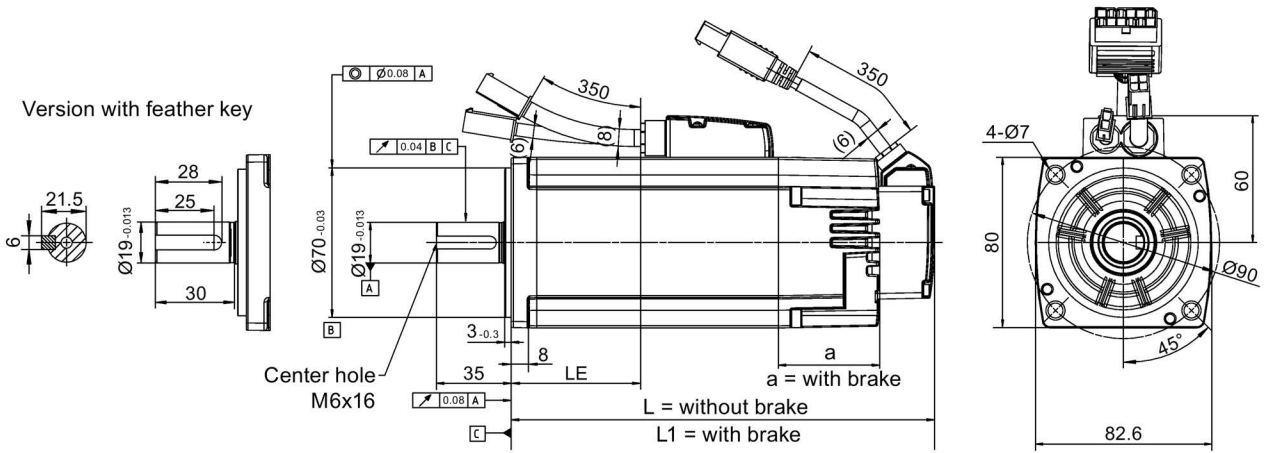

Rated power	Rated torque	a	L	L1	LE
0.75 kW	2.39 Nm	48	139	178.3	40
1.0 kW	3.18 Nm	48	158.8	198.1	60

Shaft height 50 mm, with straight connectors

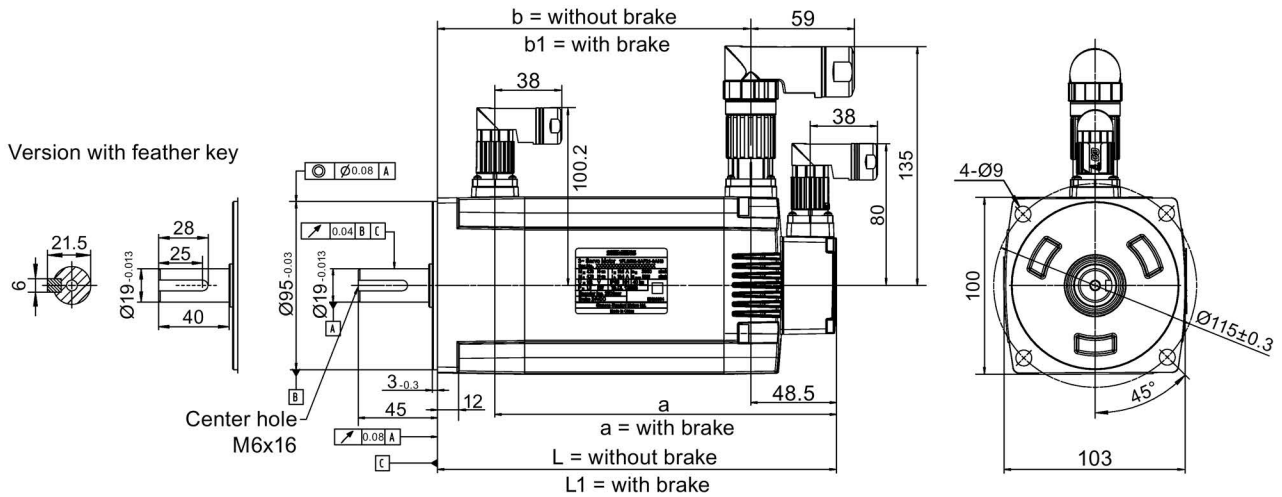

Shaft height 50 mm, with angular connectors

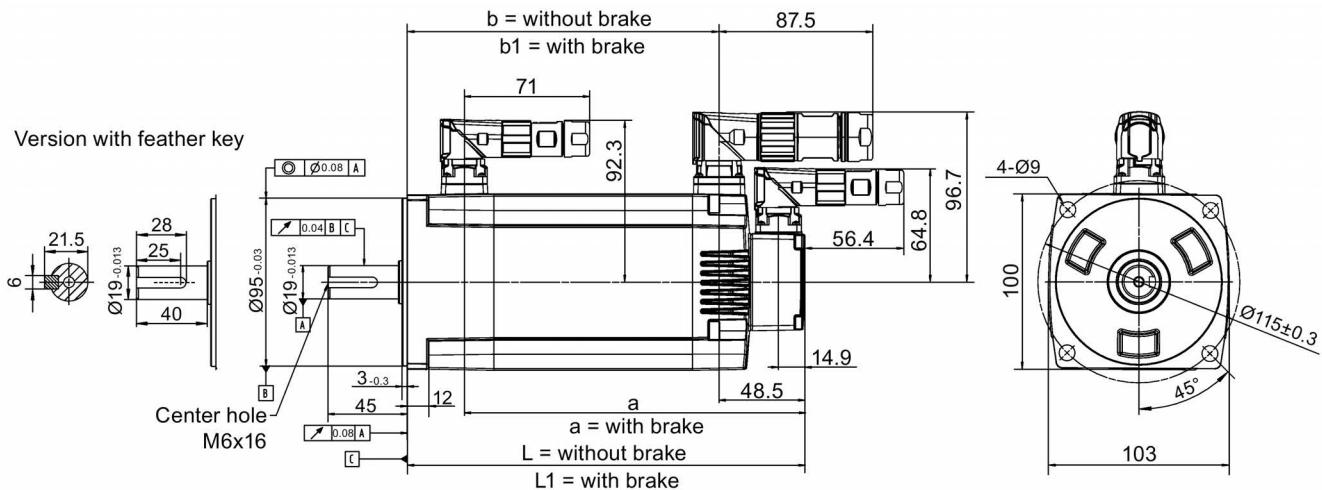

Rated power	Rated torque	a	b	b1	L	L1
1.5 kW	4.78 Nm	195	143.5	177.5	192	226
2.0 kW	6.37 Nm	219	167.5	201.5	216	250

SIMOTICS S-1FL6 high inertia servo motors (unit: mm)

Shaft height 45 mm, with the incremental encoder and straight connectors

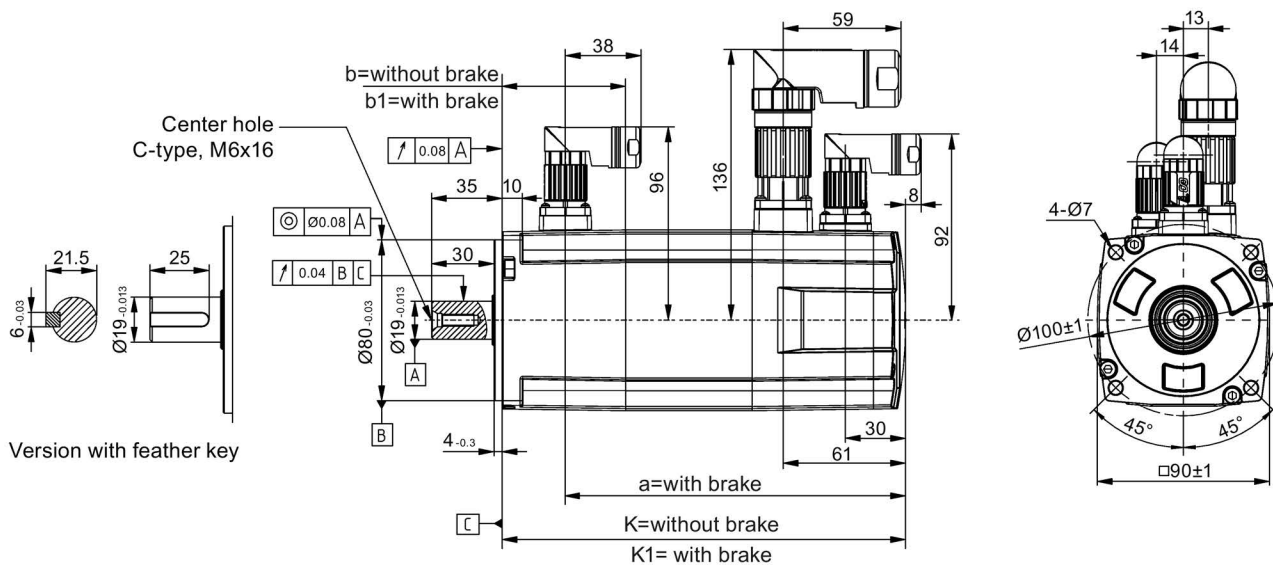

3.2 Mounting the motor

Shaft height 45 mm, with the incremental encoder and angular connectors

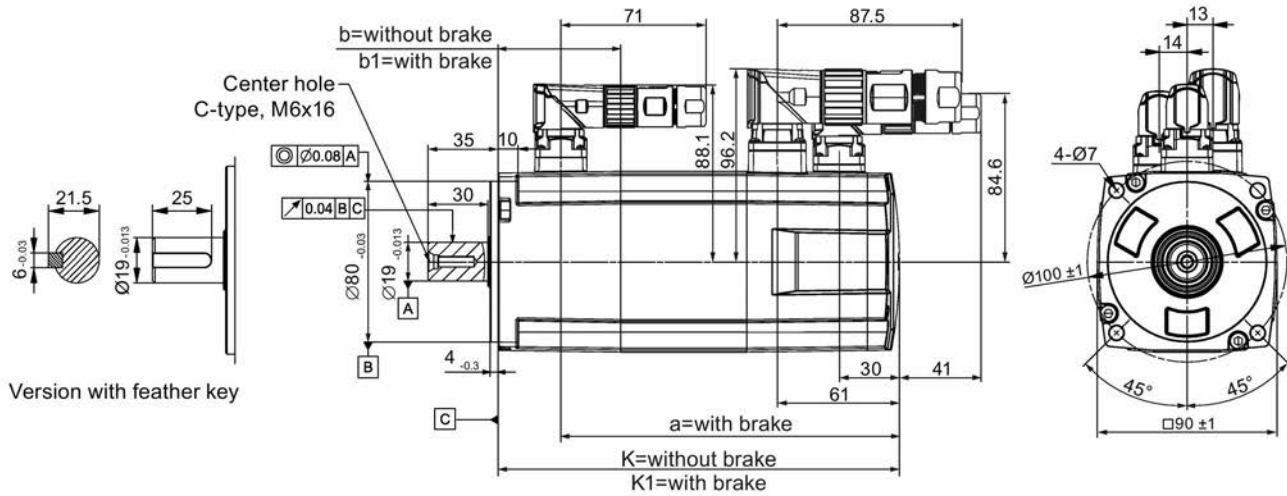

Rated power	Rated torque	K	K1	a	b	b1
0.4 kW	1.27 Nm	154.5	201	169.5	15	61.5
0.75 kW	2.39 Nm	201.5	248	216.5		

Shaft height 45 mm, with the absolute encoder and straight connectors

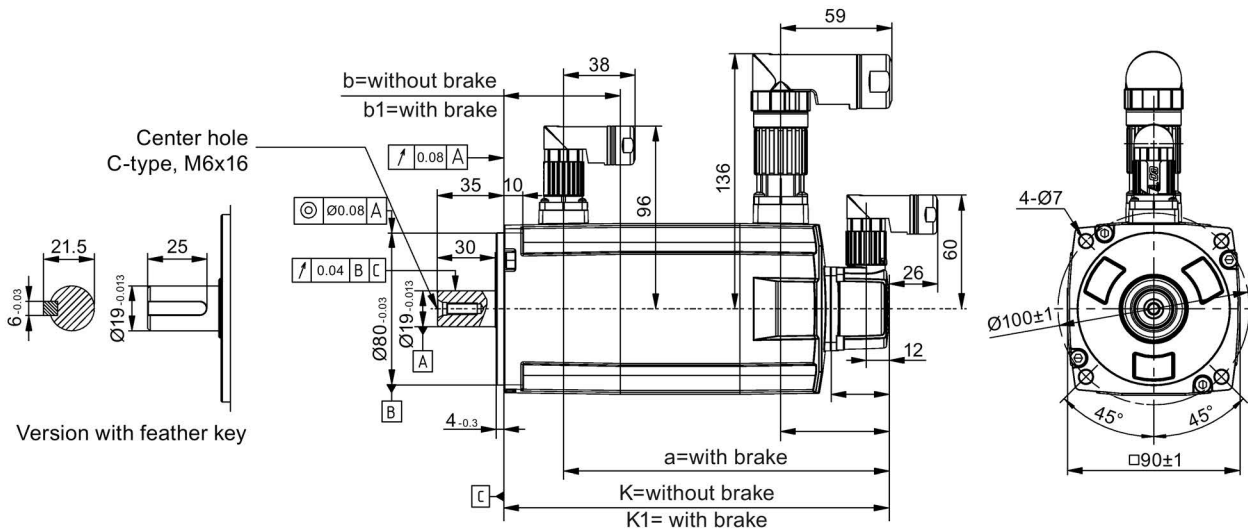

Shaft height 45 mm, with the absolute encoder and angular connectors

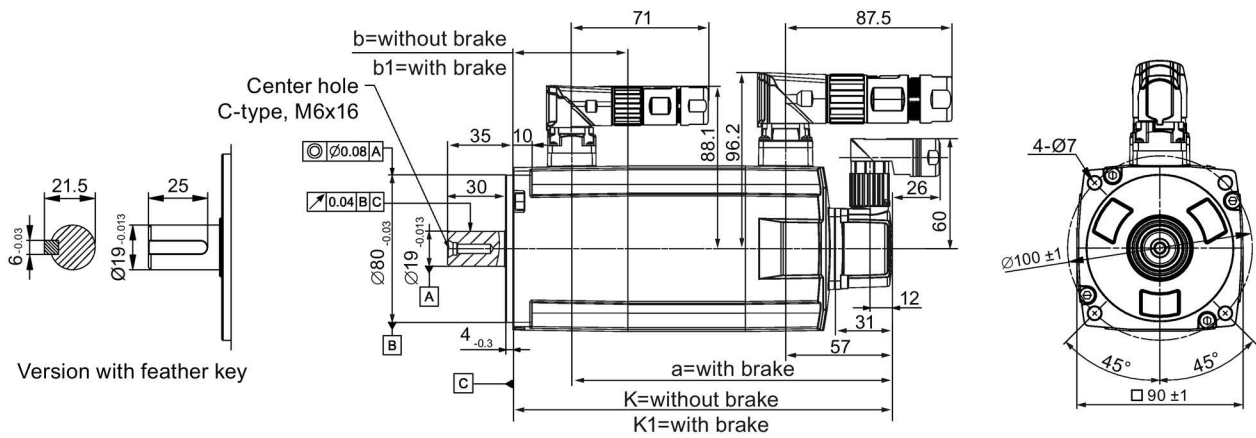

Rated power	Rated torque	K	K1	a	b	b1
0.4 kW	1.27 Nm	157	203.5	172	15	61.5
0.75 kW	2.39 Nm	204	250.5	219		

Shaft height 65 mm, with the incremental encoder and straight connectors

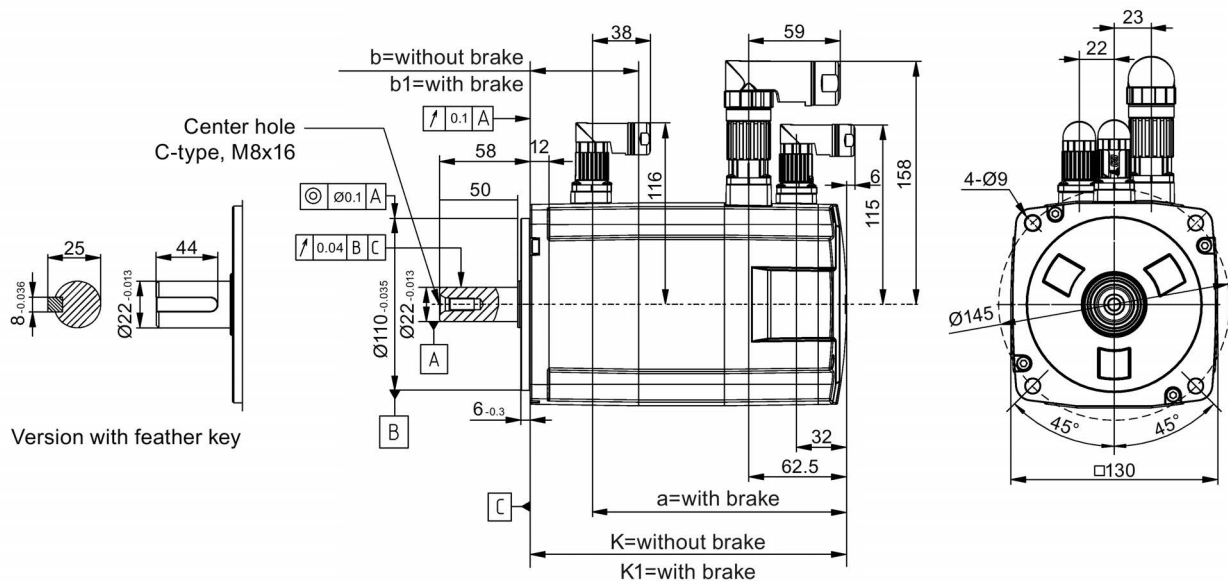

Shaft height 65 mm, with the incremental encoder and angular connectors

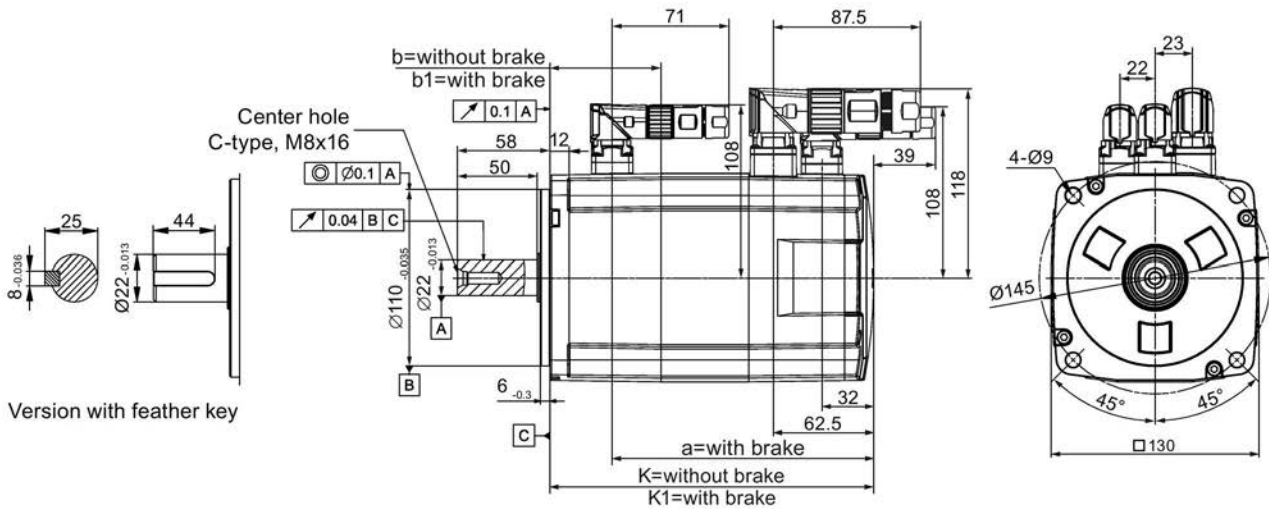

Rated power	Rated torque	K	K1	a	b	b1
0.75 kW	3.58 Nm	148	202.5	163	15	69.5
1.0 kW	4.78 Nm	181/164 ¹⁾	235.5/219 ¹⁾	196/179.5 ¹⁾		
1.5 kW	7.16 Nm	181	235.5	196		
1.75 kW	8.36 Nm	214	268.5	229		
2.0 kW	9.55 Nm	247	301.5	262		

1) The former value indicates the dimension for high inertia motors with straight connectors; the latter value indicates the dimension for high inertia motors with angular connectors.

Shaft height 65 mm, with the absolute encoder and straight connectors

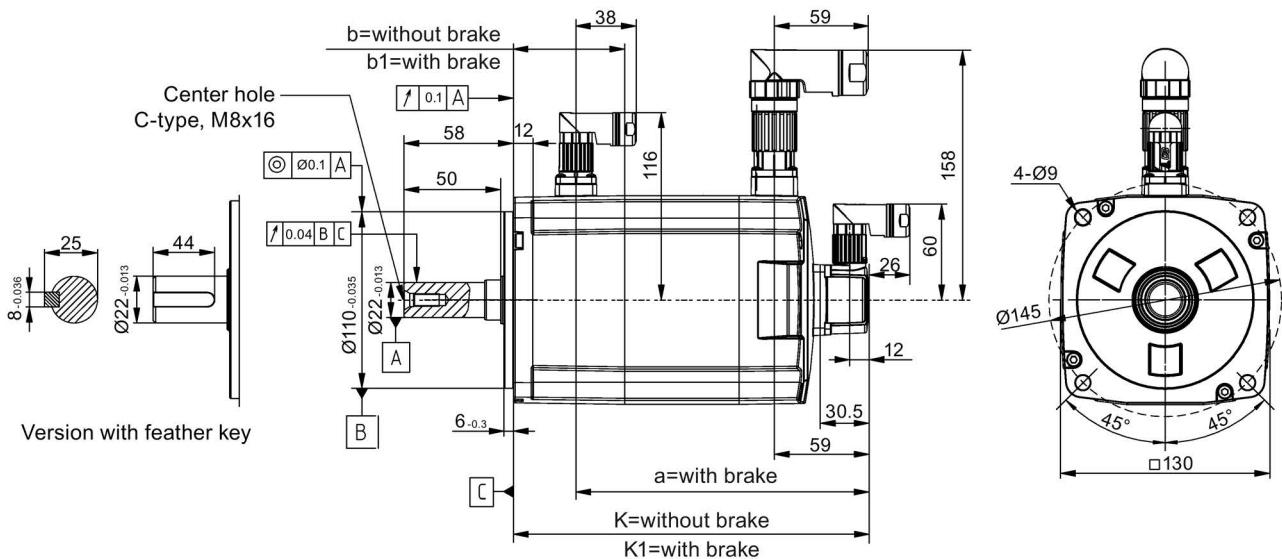

Shaft height 65 mm, with the absolute encoder and angular connectors

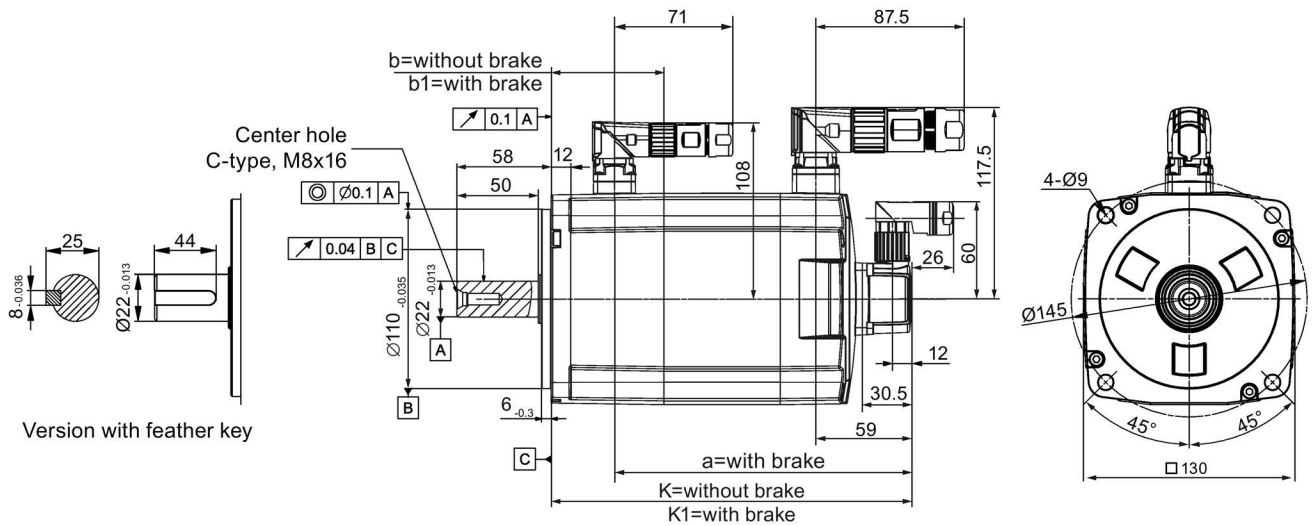

Rated power	Rated torque	K	K1	a	b	b1
0.75 kW	3.58 Nm	151	205.5	166	15	69.5
1.0 kW	4.78 Nm	184/167.5 ¹⁾	238.5/222 ¹⁾	199/182.5 ¹⁾		
1.5 kW	7.16 Nm	184	238.5	199		
1.75 kW	8.36 Nm	217	271.5	232		
2.0 kW	9.55 Nm	250	304.5	265		

¹⁾ The former value indicates the dimension for high inertia motors with straight connectors; the latter value indicates the dimension for high inertia motors with angular connectors.

Shaft height 90 mm, with the incremental encoder and straight connectors

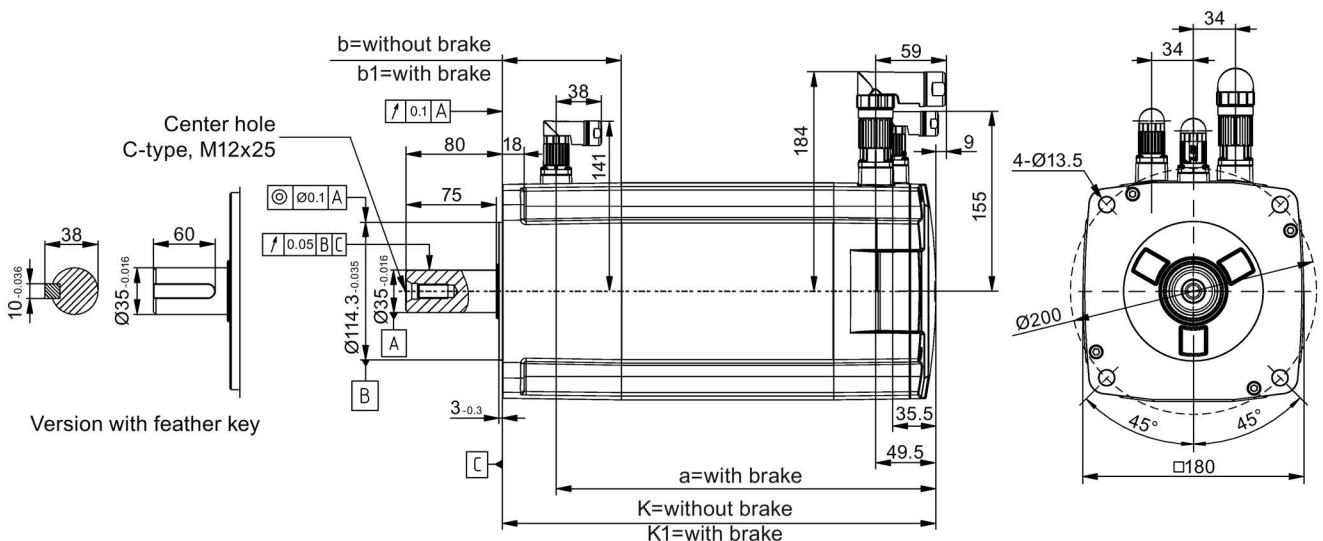

3.2 Mounting the motor

Shaft height 90 mm, with the incremental encoder and angular connectors

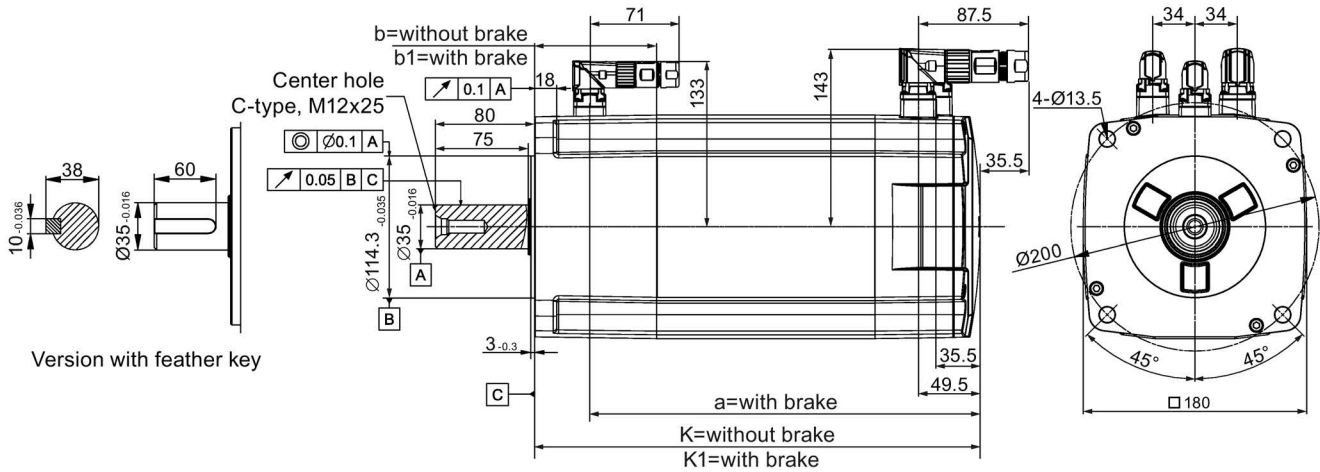

Rated power	Rated torque	K	K1	a	b	b1
2.5 kW	11.9 Nm	189.5	255	210.5	33	98.5
3.5 kW	16.7 Nm	211.5	281	236.5		
5.0 kW	23.9 Nm	237.5	307	262.5		
7.0 kW	33.4 Nm	289.5	359	314.5		

Shaft height 90 mm, with the absolute encoder and straight connectors

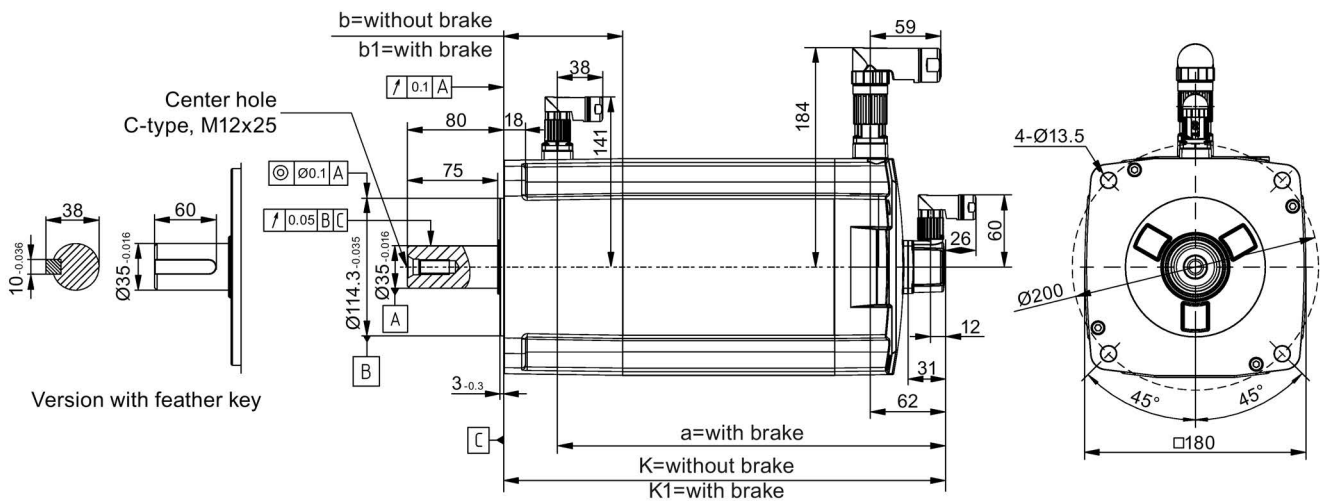

Shaft height 90 mm, with the absolute encoder and angular connectors

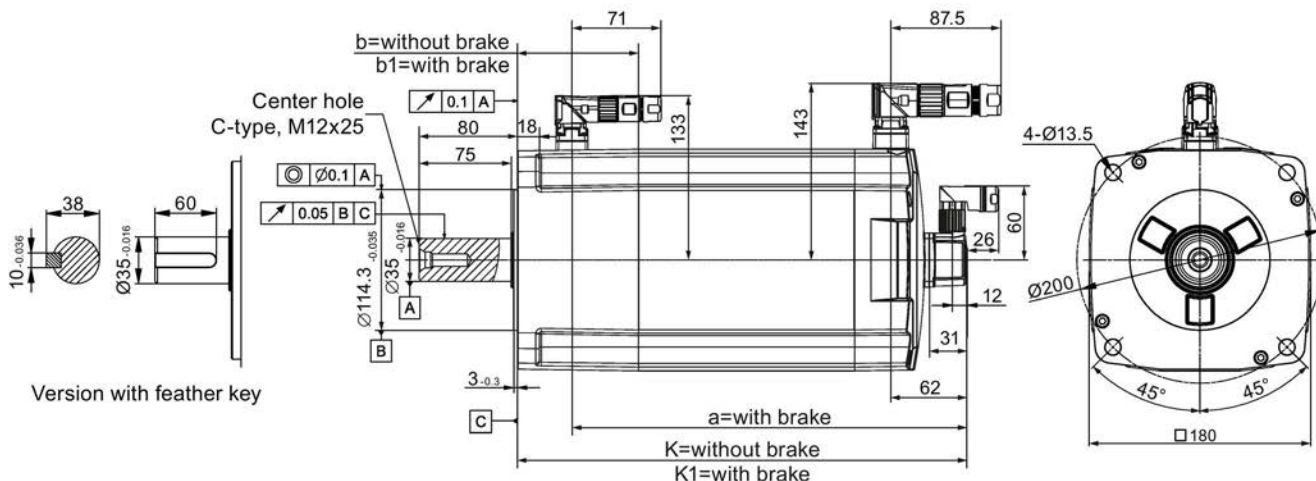

Rated power	Rated torque	K	K1	a	b	b1
2.5 kW	11.9 Nm	197	263	218	33	98.5
3.5 kW	16.7 Nm	223	289	244		
5.0 kW	23.9 Nm	249	315	270		
7.0 kW	33.4 Nm	301	367	322		

3.2.2 Mounting the motor

⚠ WARNING

Personal injury and material damage due to motor falling down

Some motors, especially the 1FL609□ are heavy. Motor falling down can cause serious personal injury or material damage.

- The excessive weight of the motor should be considered and any necessary assistance required for mounting should be sought.

NOTICE

Damage to the motor due to liquid entering

If the liquid enters the motor, the motor may be damaged

- During motor installation or operation, make sure that no liquid (water, oil, etc.) can penetrate into the motor.
- When installing the motor horizontally, make sure that the cable outlet faces downward to protect the motor from ingress of oil or water.

NOTICE

Damage to the absolute encoder due to the magnetic interference from the magnetic field

The magnetic interference from the magnetic field can cause a damage to the absolute encoder.

- To avoid magnetic interference to the absolute encoder, keep the servo motor with an absolute encoder at least 15 mm away from the devices that produce a magnetic field stronger than 10 mT.

Note

Using the eyebolts

The 1FL609□ motor (90 mm shaft height) has two M8 screw holes for screwing in two eyebolts. Lift the 1FL609□ motor only at the eyebolts.

Eyebolts that have been screwed in must be either tightened or removed after mounting.

Install the motor onto a steel flange with four screws as shown in the following figure:

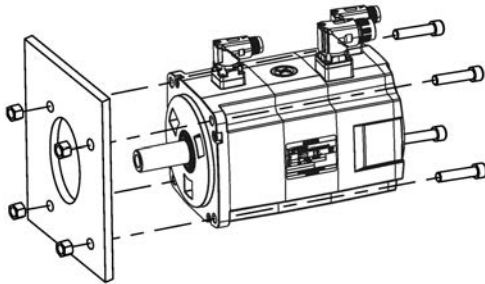

Motor	Screw	Recommended flange size	Tightening torque	Flange material
Low inertia motors				
1FL602□	2 x M4	120 x 100 x 40 (mm)	2.4 Nm	Steel
1FL603□	4 x M5	120 x 100 x 40 (mm)	4.7 Nm	
1FL604□	4 x M6	120 x 100 x 40 (mm)	8 Nm	
1FL605□	4 x M8	120 x 100 x 40 (mm)	20 Nm	
High inertia motors				
1FL604□	4 x M6	270 x 270 x 10 (mm)	8 Nm	Steel
1FL606□	4 x M8	390 x 390 x 15 (mm)	20 Nm	
1FL609□	4 x M12	420 x 420 x 20 (mm)	85 Nm	

3.2.3 Motor heating conditions

The rated motor specifications are continuous allowable values at a surrounding air temperature of 40 °C when the motor is installed with a steel flange. When the motor is mounted on a small surface, the motor temperature may rise considerably because of the limited heat radiating abilities of the surface. Make sure that you use a suitable flange according to Siemens-recommended flange sizes.

Note

The actual temperature rise depends on how the flange (motor mounting section) is fixed on the installation surface, what material is used for the motor mounting section, and motor speed. Always check the actual motor temperature.

Connecting

4.1 System connection

The SINAMICS V90 PN servo drive is integrated with digital input/output interface and PROFINET communication port. It can be connected either to a Siemens controllers like S7-1200 or S7-1500.

The following illustrations show the examples of the SINAMICS V90 PN servo system connection.

Connection diagram for FSB on the single phase power network:

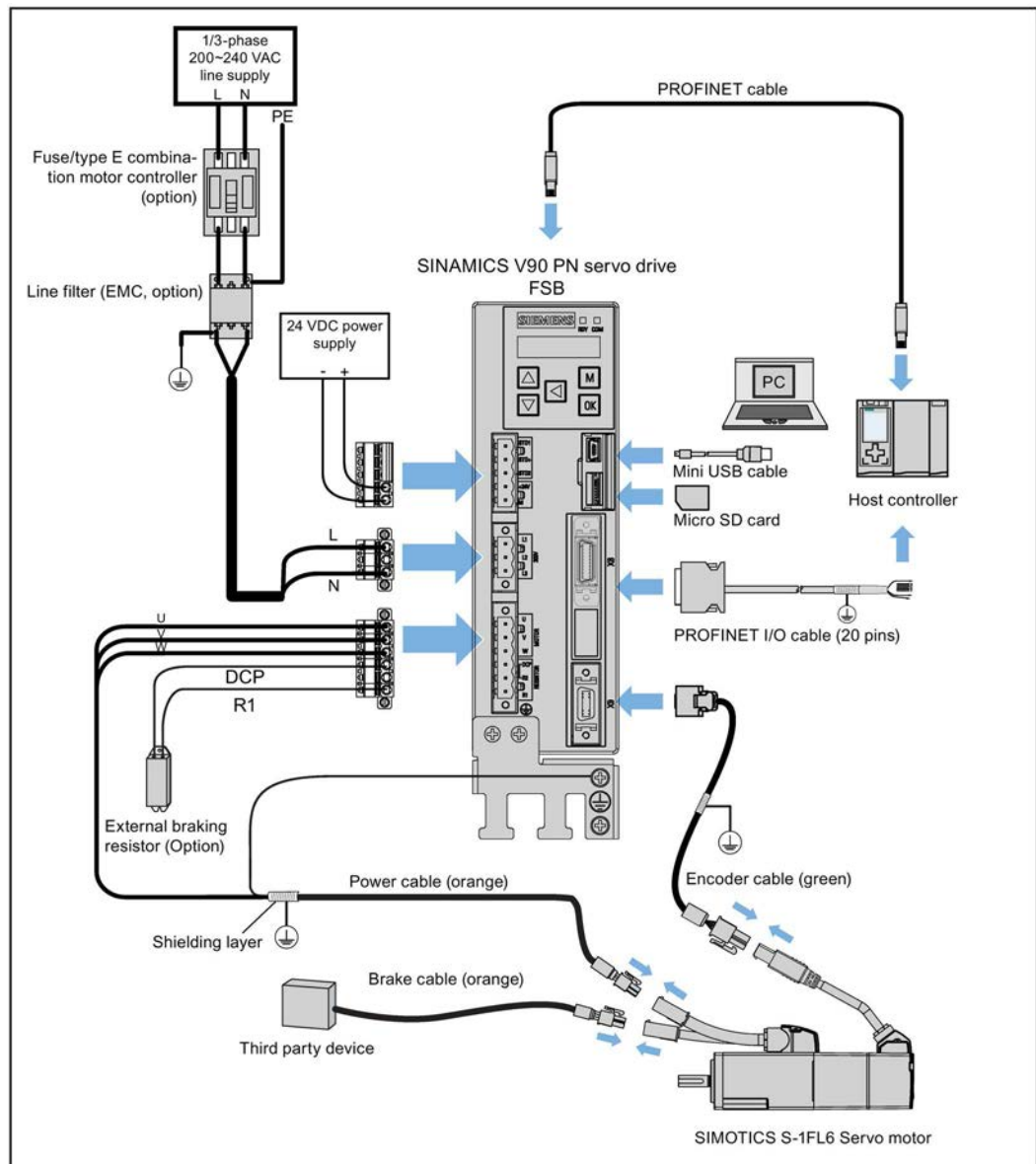

Connection diagram for FSD on the three phase power network:

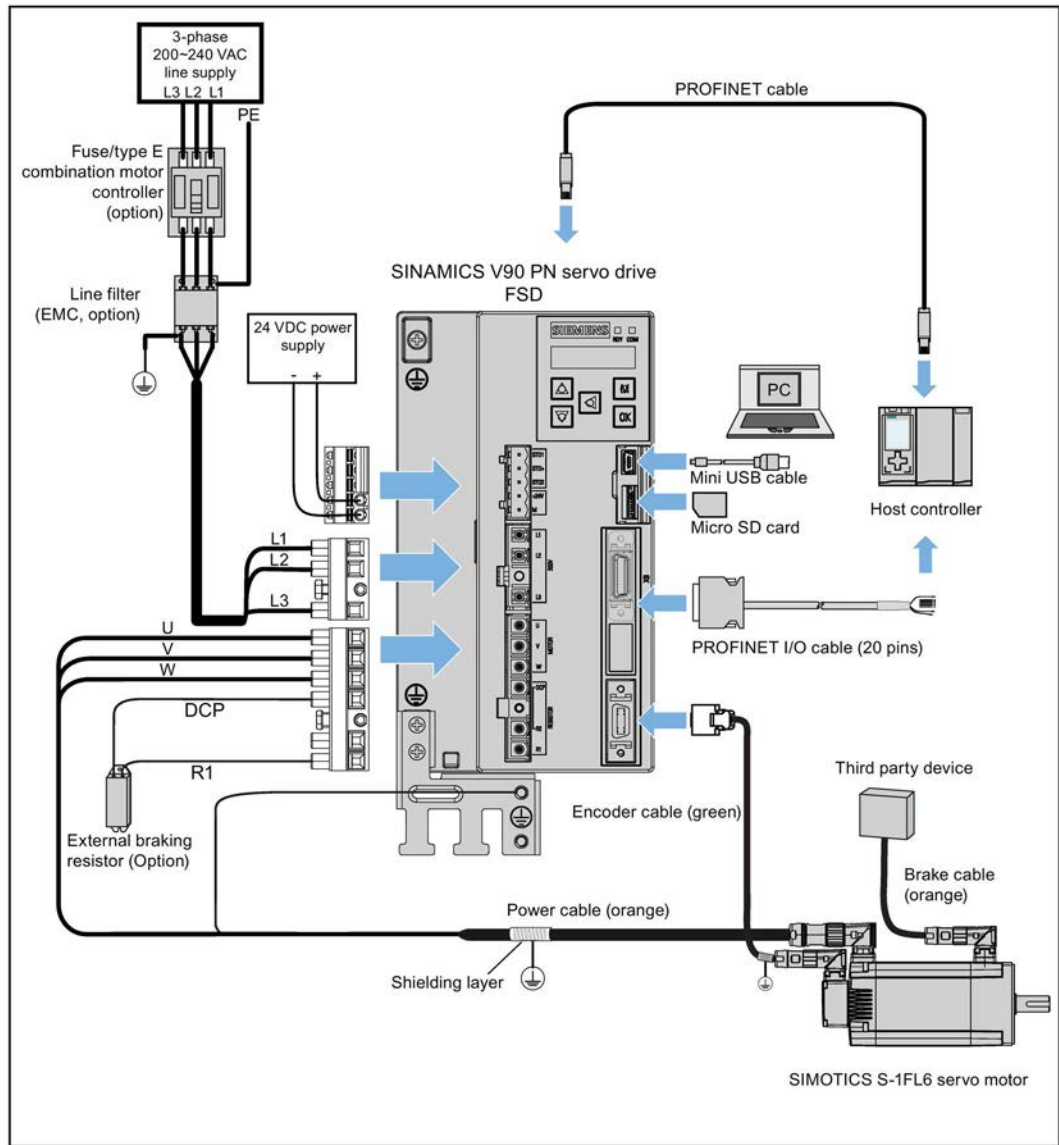

! DANGER

Danger to life when PE connectors are touched

When the equipment is working, hazardous touch current can be present at the PE connectors; if touched, this can result in death or severe personal injury.

- Do not touch the PE connector during operation or within a certain period since power disconnection.



! WARNING

Personal injury and damage to property from improper connections

Improper connections have high risks of electrical shock and short circuit, which will jeopardize personal safety and equipment.

- The drive must be directly connected with the motor. It is not permissible to connect a capacitor, inductor or filter between them.
- The line supply voltage must be within the allowable range (refer to the drive rating plate). Never connect the line supply cable to the motor terminals U, V, W or connect the motor power cable to the line input terminals L1, L2, L3.
- Never wire up the U, V, W terminals in an interchanged phase sequence.
- If the CE marking for cables is mandatory in some cases, the motor power cable, line supply cable and brake cable used must all be shielded cables.
- For terminal connection, make sure that the clearances in air between non-insulated live parts are at least 5.5 mm.
- Cables connected may not come into contact with rotating mechanical parts.

! CAUTION

Personal injury and damage to property from inadequate protection

Inadequate protection may cause minor personal injury or damage to property.

- Route a second PE conductor with the cross section of the supply system lead in parallel to the protective earth via separate terminals or use a copper protective earth conductor with a cross section of 10 mm².
- Terminals for equipotential bondings that exist in addition to terminals for PE conductors must not be used for looping-through the PE conductors.
- To ensure protective separation, an isolating transformer must be used for the 220 VAC/380 VAC line supply system.

NOTICE

Drive damage caused by short-circuiting between the shielding wire and the unused pin on the PROFINET I/O connector

The shielding wire may inadvertently be short-circuited to the unused pin on the to-be-assembled PROFINET I/O connector. This can cause damage to the drive.

- Exercise caution when connecting the shielding cable to the PROFINET I/O connector.
- You can see the assembly method of the connector in Section "Assembly of cable terminals on the drive side (Page 313)".

Note

Failure to meet the EMC requirements resulting from failure to observe the wiring instruction

Failure to meet the EMC requirements because you do not observe the wiring instruction.

- In order to meet **EMC** requirements, all cables must be shielded cables.
- Make sure that you connect the cable shields of shielded twisted-pair cables to the shielding plate or the hose clamp of the servo drive.

Note

Low Voltage Directive complied

Our products comply with EN61800-5-1: 2007 standards and Low Voltage Directive (Low Voltage Directive 2006/95/EC).

Note

For low inertia motors of shaft heights 20 mm, 30 mm and 40 mm, the encoder cable connectors may only be accessible to electrically skilled personnel.

Note

The mini-USB interface of the SINAMICS V90 PN is used for fast commissioning and diagnostics with SINAMICS V-ASSISTANT installed in the PC. Do not use it for long monitoring.

Connecting the cable shields with the shielding plate

To achieve EMC-compliant installation of the drive, use the shielding plate that is shipped with the drive to connect the cable shields. See the following example for steps of connecting cable shields with the shielding plate:

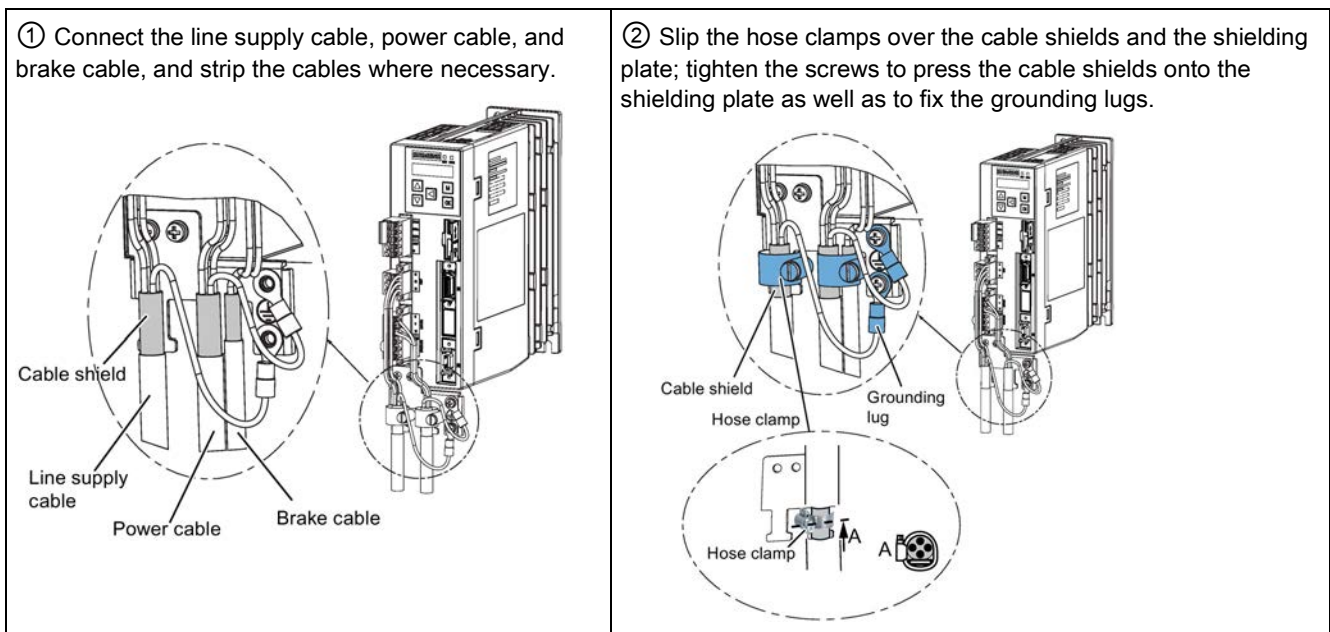



! WARNING

Risk of electric shock and fire from a network with an excessively high impedance

Excessively low short-circuit currents can lead to the protective devices not tripping or tripping too late, and so causing electric shock or a fire.

- In the case of a conductor-conductor or conductor-ground short-circuit, ensure that the short-circuit current at the point where the drive is connected to the line supply at least meets the minimum requirements for the response of the protective device used.
- You must use an additional residual-current device (RCD) if a conductor-ground short circuit does not reach the short-circuit current required for the protective device to respond. The required short-circuit current can be too low, especially for TT systems.



! WARNING

Risk of electric shock and fire from a network with an impedance that is too low

Excessively high short-circuit currents can lead to the protective devices not being able to interrupt these short-circuit currents and being destroyed, and so causing electric shock or a fire.

- Ensure that the uninfluenced short-circuit current at the line terminal of the drive does not exceed the breaking capacity (SCCR or I_{cc}) of the protective device used.



! WARNING

Death or severe personal injury from electrical shock

The earth leakage current for the drive can be greater than AC 3.5 mA, which may cause death or severe personal injury due to electrical shock.

- A fixed earth connection is required to eliminate the dangerous leakage current. In addition, the minimum size of the protective earth conductor shall comply with the local safety regulations for high leakage current equipment.

Adjusting cable directions from the motor side

For some low inertia motors and all high inertia motors, you can adjust the direction of the power cable, encoder cable, or brake cable from the motor side to facilitate cable connection.

The following illustrations take high inertia motors with the incremental encoder for example to show how to adjust the cable directions.

Low inertia motors with a shaft height of 50 mm and high inertia motors with straight connectors

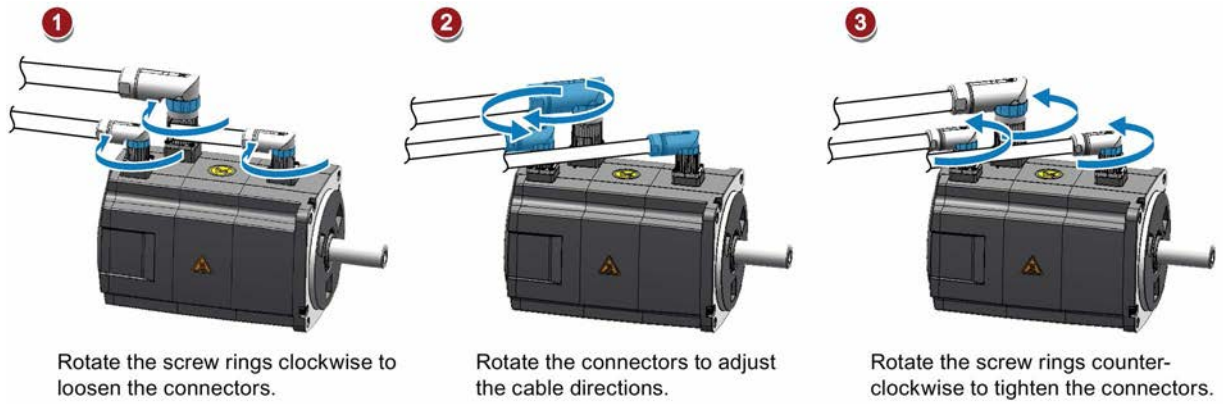

Note
Rotating the connectors

You can rotate all the three motor-side connectors only within 360°.

High inertia motors with angular connectors

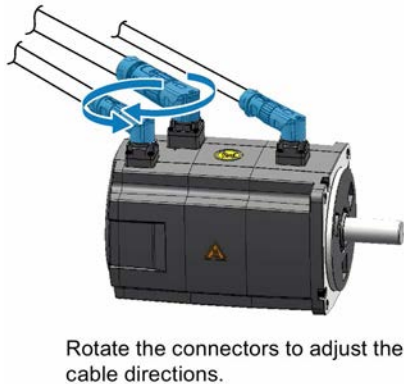

Note
Rotating the connectors

You can rotate all the three motor-side connectors only within 310°.

Note
For an absolute encoder cable on a high inertia motor with angular connectors, adjust its direction just the same as you adjust the cable directions on a high inertia motor with straight connectors mentioned above.

4.2 Main circuit wiring

4.2.1 Line supply - L1, L2, L3

Signal	Description
200 V variant	
L1	Line phase L1
L2	Line phase L2
L3	Line phase L3
Recommended minimum cable cross-section: When used on the single phase power network: FSA: 0.33 mm ² FSB: 0.52 mm ² FSC: 1.31 mm ² When used on the three phase power network: FSA and FSB: 0.33 mm ² FSC: 0.52 mm ² FSD (1 kW): 0.82 mm ² FSD (1.5 kW to 2 kW): 2.08 mm ²	
400 V variant	
L1	Line phase L1
L2	Line phase L2
L3	Line phase L3
Recommended minimum cable cross-section: FSAA and FSA: 1.5 mm ² FSB and FSC: 2.5 mm ²	

Note

For 200 V variant servo drive, when using the FSA, FSB and FSC on the single phase power network, you can connect the power supply to any two connectors of L1, L2, and L3.

Assembling the line supply cable terminals

The procedure of assembling a line supply cable terminal is the same as that for a power cable terminal on the drive side.

For more information, see Section "Assembly of cable terminals on the drive side (Page 313)".

Attaching the line supply cable

⚠ CAUTION

Risk of injury due to improper cable connection

When attaching the line supply cable to a line supply connector that has not been fixed on the drive, you can injure your fingers.

- Make sure you first assemble the line supply connector to the drive and tighten the fixing screws on the connector, and then attach the cable to the connector.

200 V variant

- For FSA and FSB

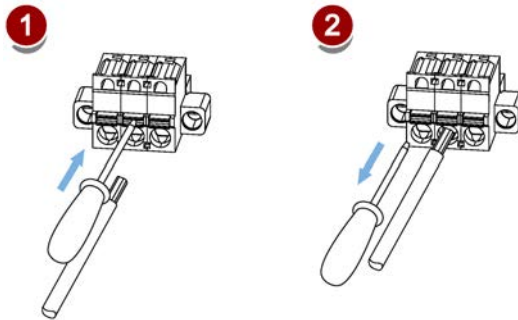

- For FSC and FSD

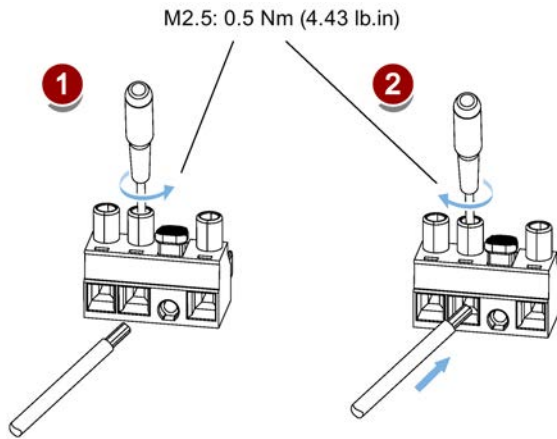

400 V variant

- For FSAA and FSA

You can attach the line supply cable with the same method for 200 V variant drives of frame sizes FSC and FSD.

- For FSB and FSC

The FSB and FSC servo drives are equipped with barrier terminals for line supply connection. You can fix the line supply cable on the servo drives by using the M4 screws with a tightening torque of 2.25 Nm (19.91 lb.in).

4.2.2 Motor power - U, V, W

Motor output - drive side

Signal	Description
200 V variant	
U	Motor phase U
V	Motor phase V
W	Motor phase W
Recommended minimum cable cross-section: FSA and FSB: 0.75 mm ² FSC and FSD (1 kW): 0.75 mm ² FSD (1.5 kW to 2 kW): 2.5 mm ²	
400 V variant	
U	Motor phase U
V	Motor phase V
W	Motor phase W
Recommended minimum cable cross-section: FSAA and FSA: 1.5 mm ² FSB and FSC: 2.5 mm ²	

Power connector - motor side

Illustration	Pin No.	Signal	Color	Description
Low inertia motor, shaft height: 20 mm, 30 mm, and 40 mm				
	1	U	Black	Phase U
	2	V	Black	Phase V
	3	W	Black	Phase W
	4	PE	Yellow-green	Protective earthing
Low inertia motor, shaft height: 50 mm High inertia motor, shaft height: 45 mm, 60 mm, and 90 mm				
Straight connectors: Angular connectors: 	1	U	Black	Phase U
	2	V	Black	Phase V
	3	W	Black	Phase W
	4/⊥	PE	Yellow-green	Protective earthing

Wiring

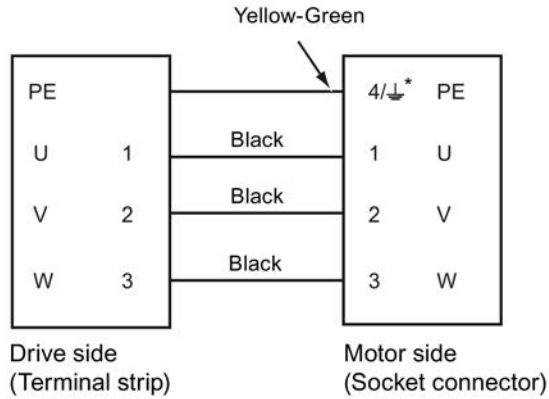

- * 4: high inertia motors with straight connectors and all low inertia motors
- ⊥: high inertia motors with angular connectors

Attaching the motor power cable

⚠ CAUTION

Risk of injury due to improper cable connection

When attaching the motor power cable to a motor power connector that has not been fixed on the drive, you can injure your fingers.

- Make sure you first assemble the motor power connector to the drive and tighten the fixing screw on the connector, and then attach the cable to the connector.

200 V variant

- FSA and FSB

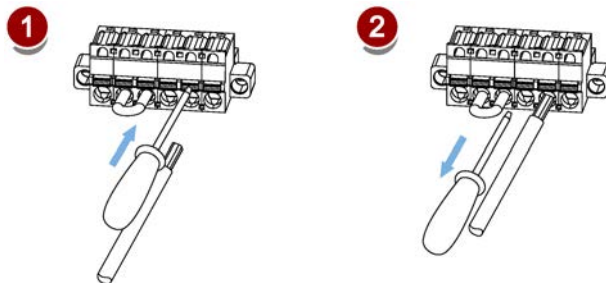

- FSC and FSD

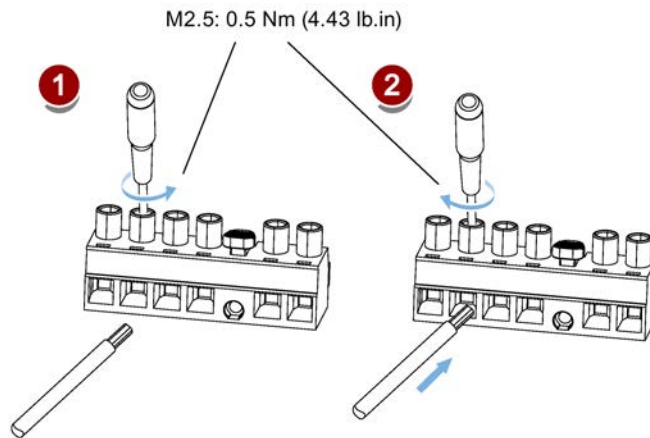

400 V variant

- For FSAA and FSA

You can attach the motor power cable with the same method for 200 V variant drives of frame sizes FSC and FSD.

- For FSB and FSC

The FSB and FSC servo drives are equipped with barrier terminals for motor power connection. You can fix the motor power cable on the servo drives by using the M4 screws with a tightening torque of 2.25 Nm (19.91 lb.in).

4.3 Control/status interface - X8

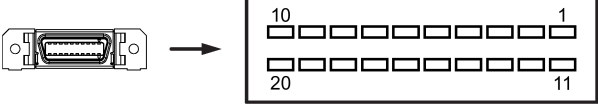
Pin	Signal	Description	Pin	Signal	Description
 <p>Type: 20-pin MDR socket</p>					
Digital inputs/outputs					
1	DI1	Digital input 1	11	DO1+	Digital output 1, positive
2	DI2	Digital input 2	12	DO1-	Digital output 1, negative
3	DI3	Digital input 3	13	DO2+	Digital output 2, positive
4	DI4	Digital input 4	14	DO2-	Digital output 2, negative
6	DI_COM	Common terminal for digital inputs	17 *	BK+	Motor holding brake control signal, positive
7	DI_COM	Common terminal for digital inputs	18 *	BK-	Motor holding brake control signal, negative
None					
5	-	Reserved	15	-	Reserved
8	-	Reserved	16	-	Reserved
9	-	Reserved	19	-	Reserved
10	-	Reserved	20	-	Reserved

* The pins are used to connect the brake control signals for 200 V variant drive only.

4.3.1 Digital inputs/outputs (DIs/Dos)

SINAMICS V90 PN supports free assignment of signals to the following digital input and output terminals depending on the control mode selected:

DI1 to DI4 -- Assignable with parameters p29301 to p29304

DO1 to DO2 -- Assignable with parameters p29330 to p29331

For detailed information about default DI/DO signal assignments, see the table below:

Pin	Digital in-puts/outputs	Parameters	Default values/signals
1	DI1	p29301	2 (RESET)
2	DI2	p29302	11 (TLIM)
3	DI3	p29303	0
4	DI4	p29304	0
11	DO1	p29330	2 (FAULT)
13	DO2	p29331	9 (OLL)

Note

The selected DI signal will respond with a delay time of 8 to 16 ms.

Note

DO signal inverse

The logics of digital output signals DO1 and DO2 can be inverted. You can invert the logics of DO1 and DO2 by setting the bit 0 and bit 1 of parameter p0748.

4.3.1.1 DIs

You can assign a maximum of seven internal digital input signals to the SINAMICS V90 PN servo drive. For detailed information about these signals, see the table below:

Name	Type	Description
RESET	Edge 0→1	Reset alarms <ul style="list-style-type: none"> 0→1: reset alarms
TLIM	Level	Torque limit selection You can select two internal torque limit sources with the digital input signal TLIM. <ul style="list-style-type: none"> 0: internal torque limit 1 1: internal torque limit 2
SLIM	Level	Speed limit selection You can select two internal speed limit sources with the digital input signal SLIM. <ul style="list-style-type: none"> 0: internal speed limit 1 1: internal speed limit 2
EMGS	Level	Emergency stop <ul style="list-style-type: none"> 0: emergency stop 1: servo drive is ready to run
REF	Edge 0→1	Setting the reference point with a digital input or reference cam input for reference approaching mode <ul style="list-style-type: none"> 0→1: reference input
CWL	Edge 1→0	Clockwise over-travel limit (positive limit) <ul style="list-style-type: none"> 1: condition for operation 1→0: emergency stop (OFF3)
CCWL	Edge 1→0	Counter-clockwise over-travel limit (negative limit) <ul style="list-style-type: none"> 1: condition for operation 1→0: emergency stop (OFF3)

Wiring

The digital inputs support both PNP and NPN types of wirings. You can find detailed information from the following diagrams:

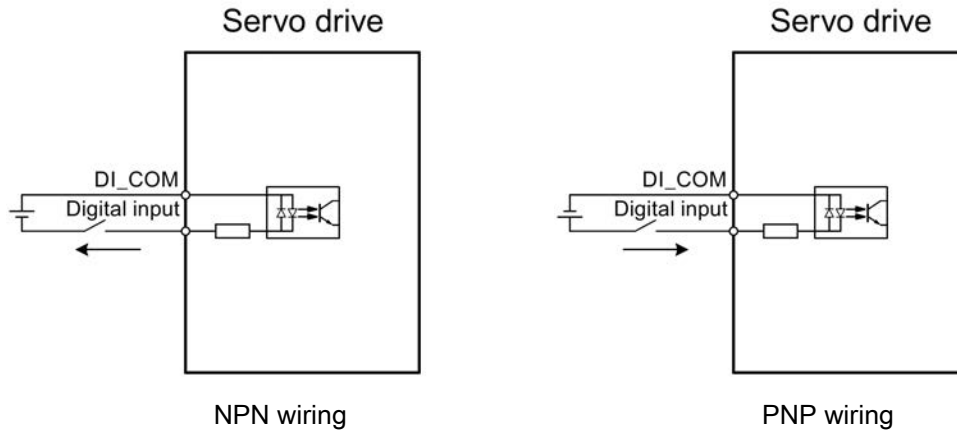

4.3.1.2 DOs

You can assign a maximum of 10 internal digital output signals to the SINAMICS V90 PN servo drive. For detailed information about these signals, see the table below:

Name	Descriptions
RDY	Servo ready <ul style="list-style-type: none"> 1: the drive is ready. 0: the drive is not ready (a fault occurs or the enable signal is missing).
FAULT	Fault <ul style="list-style-type: none"> 1: in the fault state. 0: no fault.
ZSP	Zero speed detection <ul style="list-style-type: none"> 1: motor speed \leq zero speed (can be set with parameter p2161). 0: motor speed $>$ zero speed + hysteresis (10 rpm).
TLR	Torque limit reached <ul style="list-style-type: none"> 1: the generated torque has nearly (internal hysteresis) reached the value of the positive torque limit or negative torque limit. 0: the generated torque has not reached any torque limit.
MBR	Motor holding brake <ul style="list-style-type: none"> 1: the motor holding brake is engaged. 0: the motor holding brake is released. <p>Note: MBR is only a status signal because the control and the power supply of the motor holding brake are realized with separate terminals.</p>

Name	Descriptions
OLL	Overload level reached <ul style="list-style-type: none"> 1: the motor has reached the parameterizable output overload level (p29080 in % of the rated torque; default: 100%; max: 300%). 0: the motor has not reached the overload level.
RDY_ON	Ready for servo on <ul style="list-style-type: none"> 1: the drive is ready for servo on. 0: the drive is not ready for servo on (a fault occurs, the main power supply is missing, or STW1.1 and STW1.2 are not set to 1). <p>Note: after the drive is in "servo on" state, the signal remains at high level (1) unless the above abnormal cases happen.</p>
INP	In-position signal <ul style="list-style-type: none"> 1: the number of droop pulses is in the preset in-position range (parameter p2544). 0: the number of droop pulses is beyond the preset in-position range.
REFOK	Referenced <ul style="list-style-type: none"> 1: referenced. 0: not referenced.
STO_EP	STO active <ul style="list-style-type: none"> 1: the enable signal is missing, indicating that STO is active. 0: the enable signal is available, indicating that STO is inactive. <p>Note: STO_EP is only a status signal for STO input terminals but not a safe DO for the Safety Integrated function.</p>

Wiring

The digital outputs support both PNP and NPN types of wirings. You can find detailed information from the following diagrams:

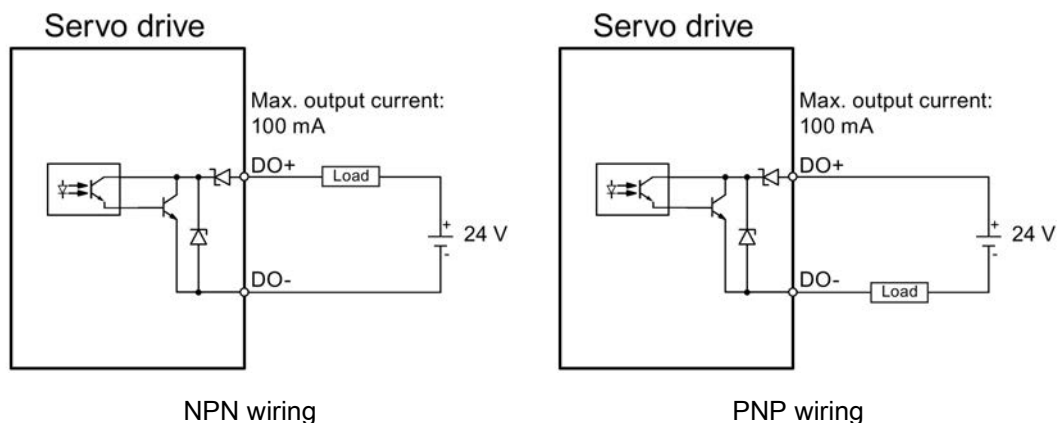

4.3.2 Standard application wiring (factory setting)

Example 1

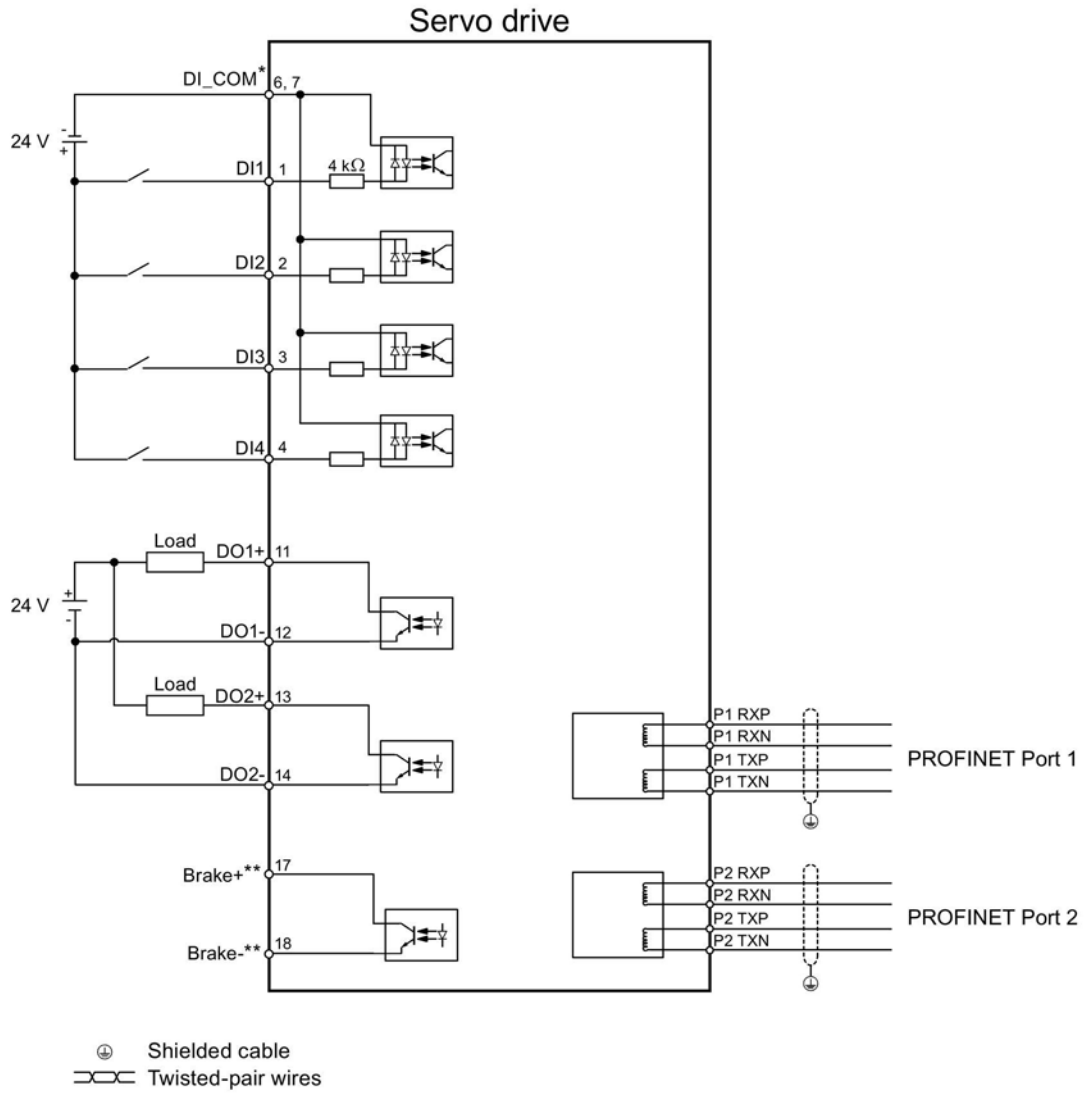

Example 2

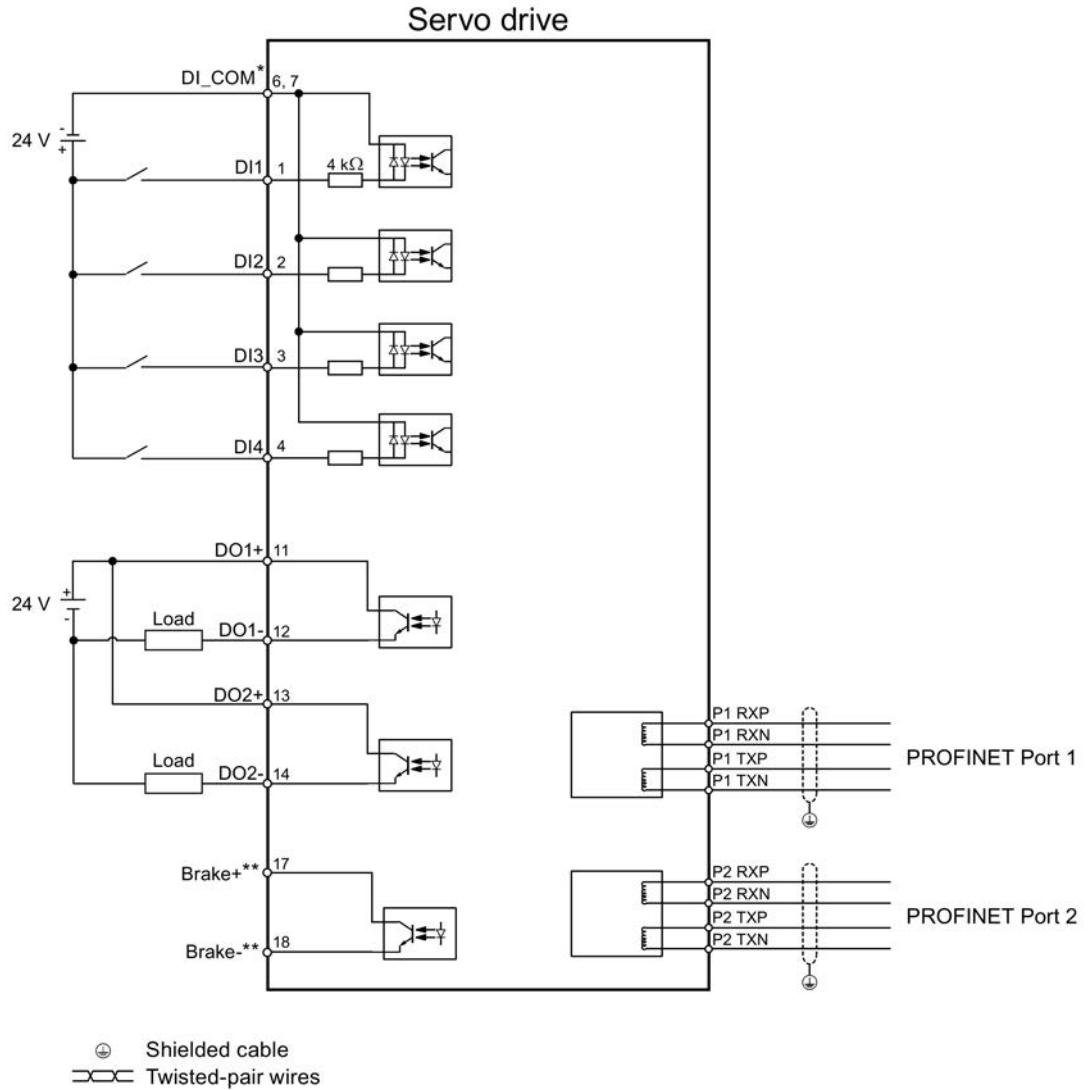

* Digital inputs, supporting both PNP and NPN types.

** The pins are used to connect the brake control signals for 200 V variant drive only. Refer to section "Motor holding brake (Page 116)" for the detailed connections.

4.3.3 Connection example with PLCs

4.3.3.1 SIMATIC S7-1200

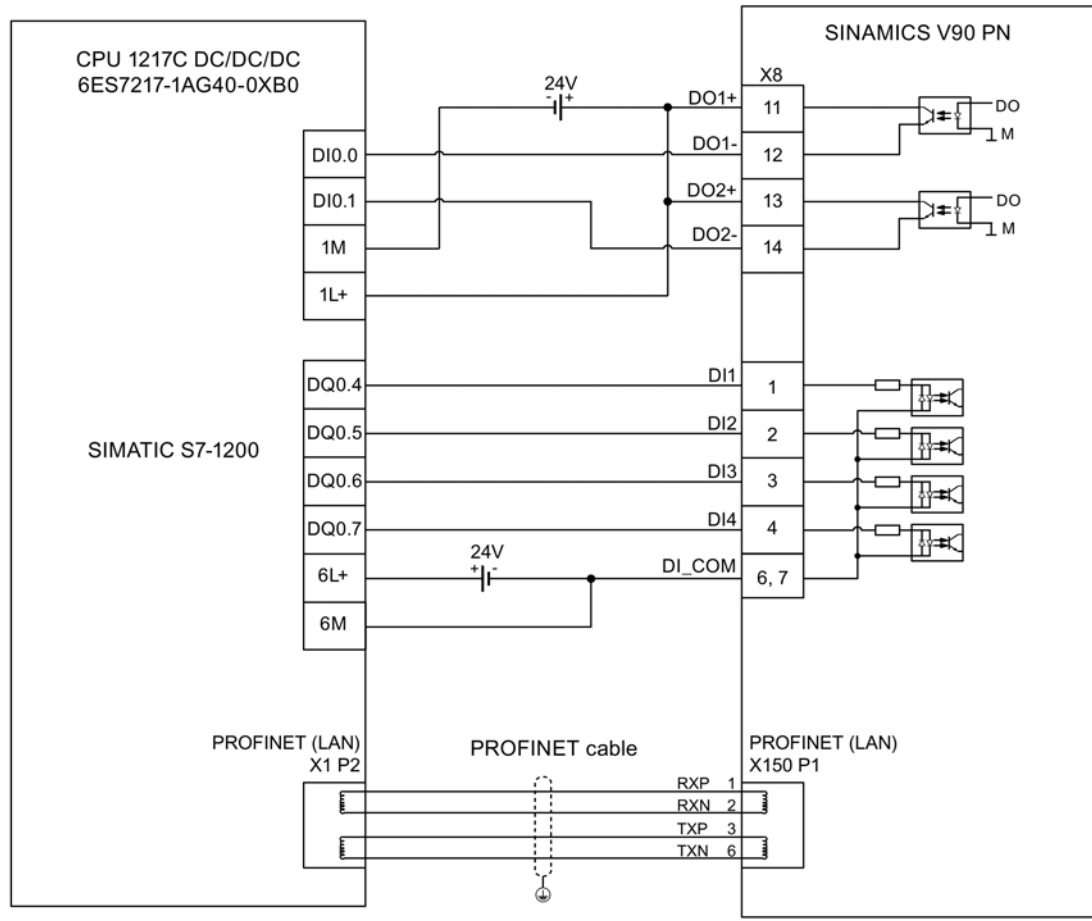

Ⓢ Shielded cable

4.3.3.2 SIMATICS S7-1500

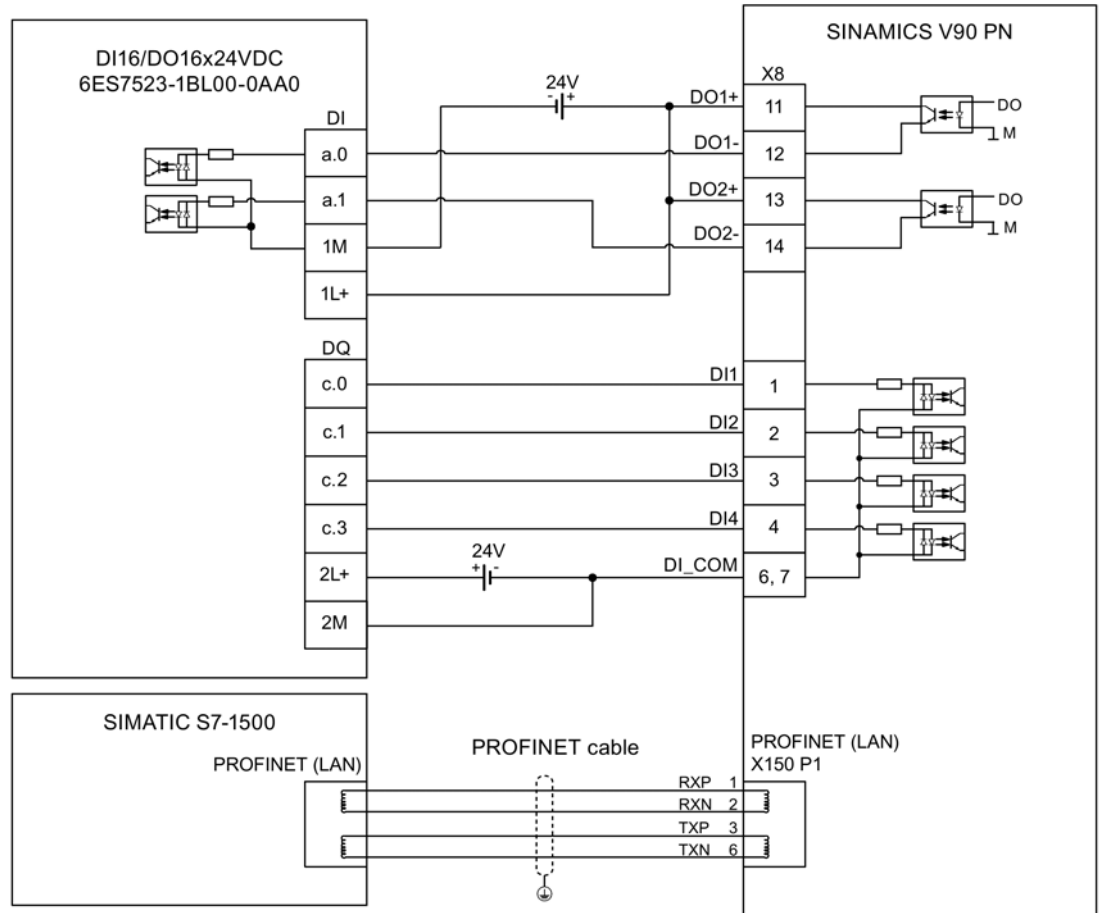

⊕ Shielded cable

4.4 24 V power supply/STO

Pin assignment

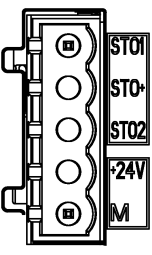
Interface	Signal name	Description	Remarks
	STO 1	Safe torque off channel 1	-
	STO +	Power supply for safe torque off	-
	STO 2	Safe torque off channel 2	-
	+24 V	Power supply, 24 VDC	Voltage tolerance: <ul style="list-style-type: none"> Without brake: -15% to +20% With brake: -10% to +10% Maximum current consumption: <ul style="list-style-type: none"> Without brake: 1.5 A With brake: 1.5 A + motor holding brake rated current (See Section "Technical data - servo motors (Page 60)")
	M	Power supply, 0 VDC	
	Maximum conductor cross-section: 1.5 mm ²		

Wiring

! WARNING

Material damages and personal injuries by the drop of a hanging axis

When the servo system is used as a hanging axis, the axis will drop if the positive and negative poles of the 24 V power supply are connected inversely. Unexpected drop of the hanging axis can cause material damages and personal injuries.

- Make sure that the 24 V power supply is correctly connected.

! WARNING

Material damages and personal injuries by the drop of a hanging axis

Unexpected drop of the hanging axis can cause material damages and personal injuries.

- It is not allowed to use the STO with a hanging axis because the axis may drop.

Note

Using the STO function

The STO1, STO+ and STO2 are short connected at the factory setting.

When the STO function is to be used, you must remove the short-circuit stick before connecting the STO interfaces. The safety function of the servo drive is SIL 2 (EN61800-5-2). If you do not need to use it any more, you must reinsert the short-circuit stick; otherwise, the motor will not run.

For detailed information about the STO function, refer to "Safety Integrated basic function (Page 225)".

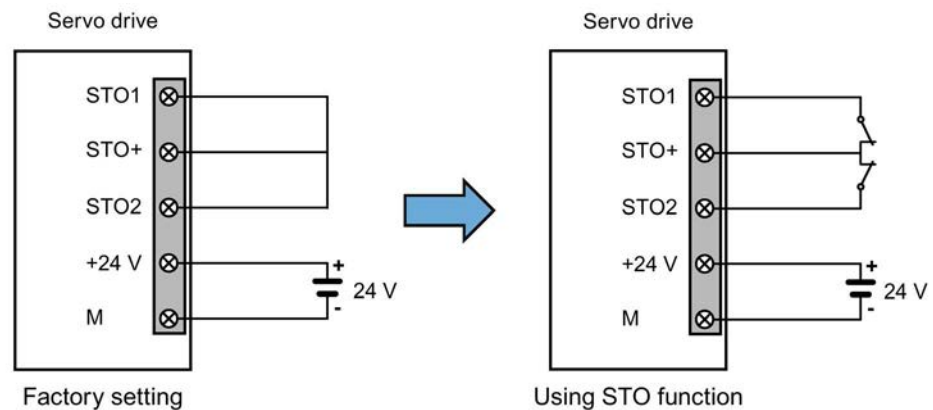

Assembling the 24 V power supply and STO cable terminals

The procedure of assembling a 24 V power cable terminal or an STO cable terminal is the same as that for a power cable terminal on the drive side of the V90 PN 200 V servo drives.

For more information, see Section "Assembly of cable terminals on the drive side (Page 313)".

Plugging the 24 V power supply and STO cables

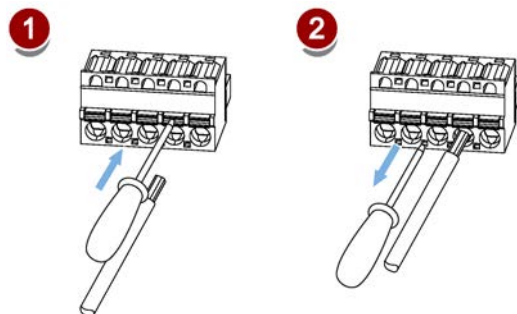

4.5 Encoder interface - X9

The SINAMICS V90 PN 200V variant servo drive supports two kinds of encoders:

- Incremental encoder TTL 2500 ppr
- Absolute encoder single-turn 21-bit

The SINAMICS V90 PN 400V variant servo drive supports two kinds of encoders:

- Incremental encoder TTL 2500 ppr
- Absolute encoder 20-bit + 12-bit multi-turn

NOTICE
Drive damage caused by short-circuiting between the shielding wire and the unused pin on the encoder connector
The shielding wire may inadvertently be short-circuited to the unused pin on the to-be-assembled encoder connector. This can cause damage to the drive.
<ul style="list-style-type: none">• Exercise caution when connecting the shielding cable to the encoder connector.• For more information, see section "Assembly of cable terminals on the drive side (Page 313)".

Note

Failure to meet the EMC requirements because the cable is not shielded

If a cable is not shielded, it cannot meet the EMC requirements.

- The encoder cable **must** be shielded to meet the EMC requirements.
-

Encoder interface - drive side

Illustration	Pin No.	Signal name	Description
	1	Biss_DataP	Absolute encoder data signal, positive
	2	Biss_DataN	Absolute encoder data signal, negative
	3	Biss_ClockN	Absolute encoder clock signal, negative
	4	Biss_ClockP	Absolute encoder clock signal, positive
	5	P5V	Encoder power supply, 5 V
	6	P5V	Encoder power supply, 5 V
	7	M	Encoder power supply, grounding
	8	M	Encoder power supply, grounding
	9	Rp	Encoder R phase positive signal
	10	Rn	Encoder R phase negative signal
	11	Bn	Encoder B phase negative signal
	12	Bp	Encoder B phase positive signal
	13	An	Encoder A phase negative signal
	14	Ap	Encoder A phase positive signal
Screw type: UNC 4-40 (plug-in terminal block) Tightening torque: 0.4 Nm			

Encoder connector - motor side

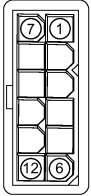
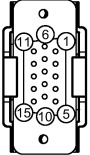
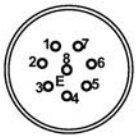

Illustration	Pin No.	Incremental encoder TTL 2500 ppr		Illustration	Absolute encoder single-turn 21-bit	
		Signal	Description		Signal	Description
Low inertia motor, shaft height: 20 mm, 30 mm and 40 mm						
	1	P_Supply	Power supply 5 V		P_Supply	Power supply 5 V
	2	M	Power supply 0 V		M	Power supply 0 V
	3	A+	Phase A+		Clock_P	Clock
	4	B+	Phase B+		Data_P	Data
	5	R+	Phase R+		n. c.	Not connected
	6	n. c.	Not connected		P_Supply	Power supply 5 V
	7	P_Supply	Power supply 5 V		M	Power supply 0 V
	8	M	Power supply 0 V		Clock_N	Inverted clock
	9	A-	Phase A-		Data_N	Inverted data
	10	B-	Phase B-		Shielding	Grounding
	11	R-	Phase R-		Note	
	12	Shielding	Grounding		The pin11 to pin15 of the absolute encoder connector are not connected.	

Illustration	Pin No.	Incremental encoder TTL 2500 ppr		Absolute encoder single-turn 21-bit Absolute encoder 20-bit + 12-bit multi-turn	
		Signal	Description	Signal	Description
Low inertia motor, shaft height: 50 mm					
High inertia motor, shaft height: 45 mm, 65 mm, and 90 mm					
Straight connectors:  Angular connectors: 	1	P_Supply	Power supply 5 V	P_Supply	Power supply 5 V
	2	M	Power supply 0 V	M	Power supply 0 V
	3	A+	Phase A+	n. c.	Not connected
	4	A-	Phase A-	Clock_N	Inverted clock
	5	B+	Phase B+	Data_P	Data
	6	B-	Phase B-	Clock_P	Clock
	7	R+	Phase R+	n. c.	Not connected
	8	R-	Phase R-	Data_N	Inverted data

Wiring

Low inertia motor, shaft height: 20 mm, 30 mm and 40 mm

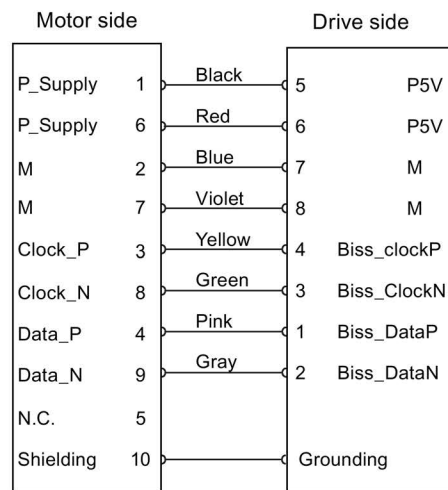
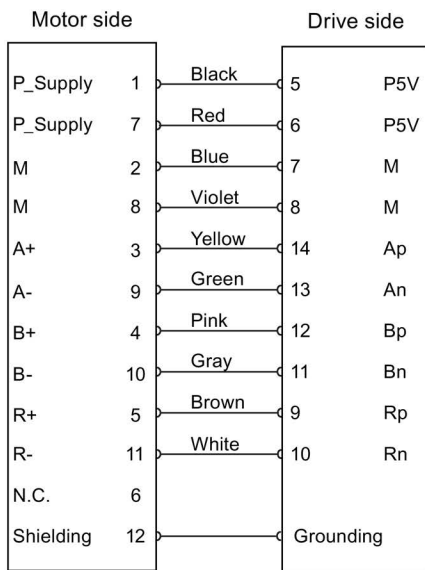

Absolute encoder single-turn 21-bit

Incremental encoder TTL 2500 ppr

Low inertia motor, shaft height: 50 mm

High inertia motor, shaft height: 45 mm, 65 mm, and 90 mm

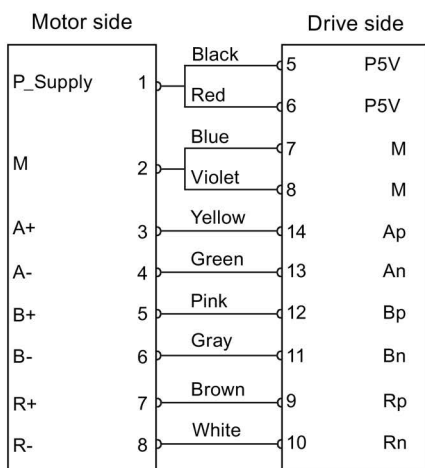

Incremental encoder TTL 2500 ppr

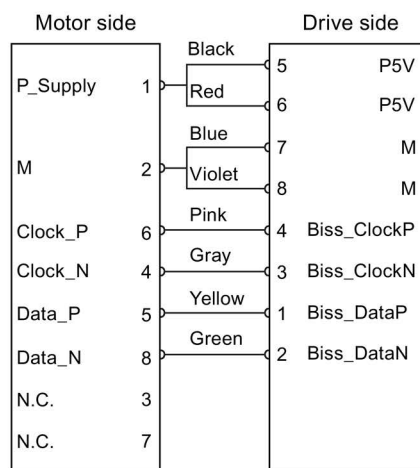

Absolute encoder single-turn 21-bit
Absolute encoder 20-bit + 12-bit multi-turn

Grounding

To ensure better EMC effects, you are recommended to strip the encoder cable and connect the cable shield to earth, as shown in the following figure:

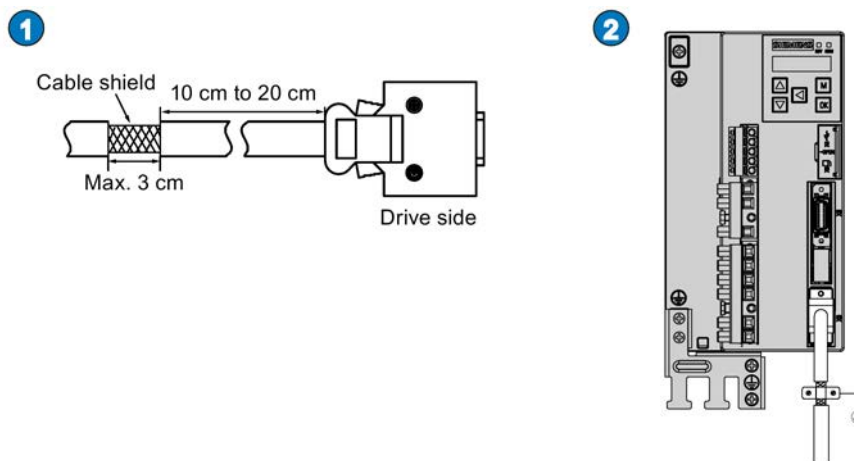

4.6 External braking resistor - DCP, R1

The SINAMICS V90 PN has been designed with an internal braking resistor to absorb regenerative energy from the motor. When the internal braking resistor cannot meet the braking requirements (e.g. the alarm A52901 is generated), you can connect an external braking resistor. For more information about how to select a braking resistor, see Section "Braking resistor (Page 45)".

Note

The 200 V variant servo drive with rated power of 0.1 kW does not have a built-in resistor.

Connecting an external braking resistor

NOTICE
Damage to the drive due to not moving the short-circuit stick between terminals DCP and R2
There is a damage to the drive if you do not move the short-circuit stick between terminals DCP and R2 when using an external resistor.
<ul style="list-style-type: none">• Before connecting an external resistor to DCP and R1, remove the connection between terminals DCP and R2.

For more information about how to connect the external braking resistor, see Section "System connection (Page 91)".

4.7 Motor holding brake

The motor holding brake is used to prevent the moving load from unwanted motions (for example, falling under the influence of gravity) when the servo system is deactivated (for example, the servo power is shut off). The servo motor can move because of its own weight or an external force even the motor power has been cut off.

The holding brake is built in the servo motors with brakes.

For 400 V variant servo drive, a motor holding brake interface (X7) is integrated in the front panel. You can connect it to a servo motor with brake to use the function of motor holding brake directly.

For 200 V variant servo drive, no specific interface is integrated. To use the function, you need to connect the drive to a third-party device via the control/status interface (X8).



Note

- Use this brake for the "hold" purpose only, that is, to hold the stalling state only. Never use this for the "brake" purpose to stop the load in motion. Use the holding brake only to hold a stopped motor.
 - The holding brake is activated at the same time when the motor power is cut off.
-

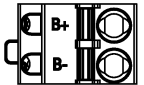
Motor holding brake interface - drive side (for the 400 V variant servo drive only)

Illustration	Signal	Description
	B+	24 V, motor brake voltage positive
	B-	0 V, motor brake voltage negative
Maximum conductor cross-section: 1.5 mm ² Input voltage tolerance: 24 V ± 10%		

Brake connector - motor side

Illustration	Pin No.	Signal	Description
Low inertia motor, shaft height: 20 mm, 30 mm and 40 mm			
	1	Brake+	Phase Brake+
	2	Brake-	Phase Brake-
Low inertia motor, shaft height: 50 mm High inertia motor, shaft height: 45 mm, 65 mm, and 90 mm			
Straight connectors:  Angular connectors: 	1	Brake+	Phase Brake+
	2	Brake-	Phase Brake-

Single status

The following table describes the states of various interfaces and components when the brake works.

- 200 V variant

Status	MBR (DO)	Brake control (Brake)	Relay	Motor brake function	Motor shaft
Brake engagement	High level (1)	Brake off	Without current	Opened	Cannot run
Brake release	Low level (0)	Brake on	With current	Closed	Can run

- 400 V variant

Status	MBR (DO)	Brake control (B+, B-)	Motor brake function	Motor shaft
Brake engagement	High level (1)	0 V	Opened	Cannot run
Brake release	Low level (0)	24 V	Closed	Can run

DO signal

Signal type	Signal name	Setting	Description
DO	MBR	ON = high level (1)	Motor holding brake is closed.
		OFF = low level (0)	Motor holding brake is released.

You can also change the assignment of the digital output signal MBR and assign it to any DO pin with one of the following parameters:

Parameter	Range	Factory setting	Unit	Description
p29330	1 to 14	2 (FAULT)	-	Assignment of digital output 1
p29331	1 to 14	9 (OLL)	-	Assignment of digital output 2

Note

Refer to Section "Digital inputs/outputs (DIs/Dos) (Page 102)" for detailed information about the digital outputs.

Wiring for the 200 V variant servo drive

The following diagrams show the examples when the brake is controlled through the motor holding brake signal (Brake) of the 200 V variant servo drive.

Example 1:

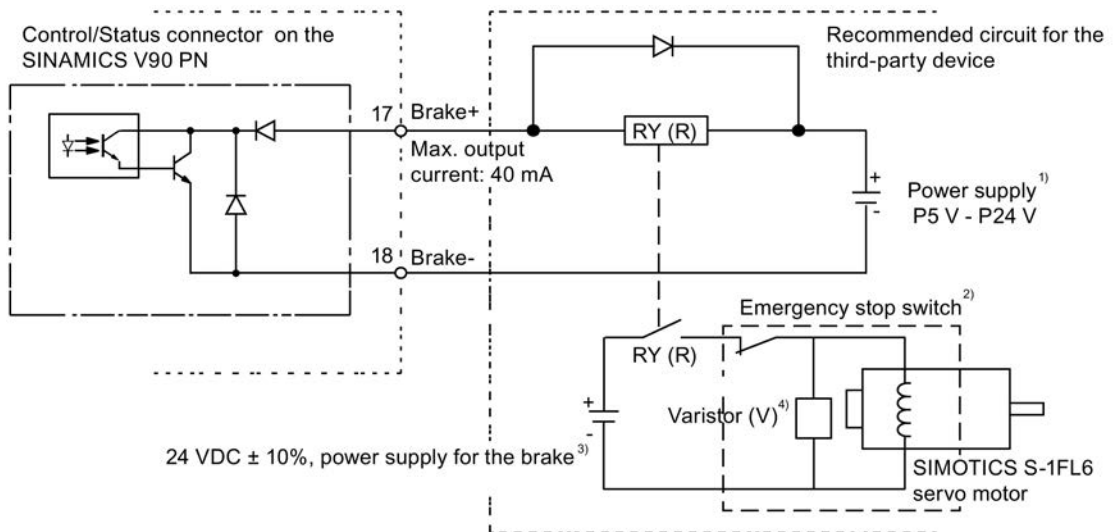

Example 2:

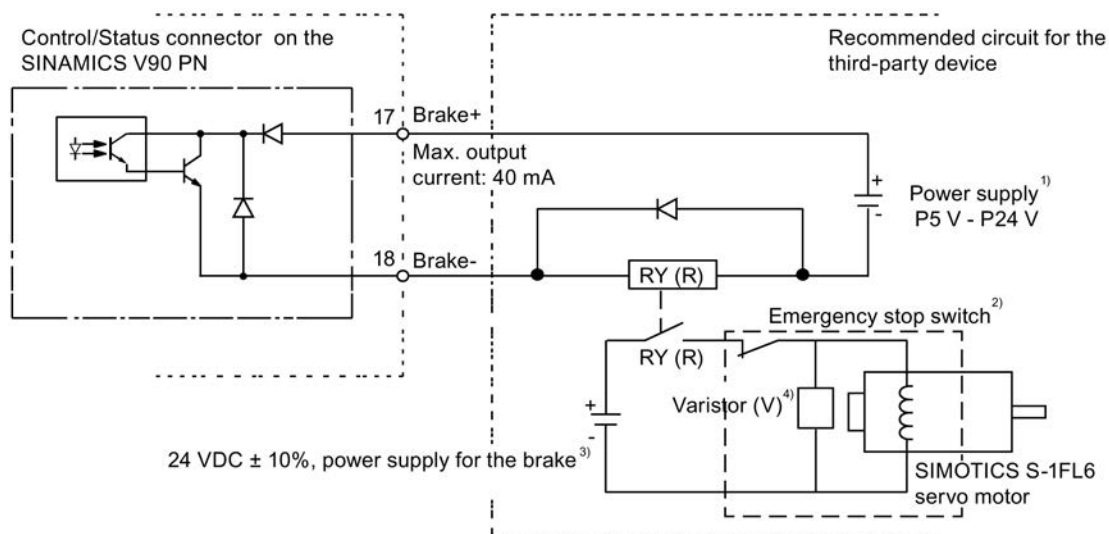
**Note**

- ¹⁾ It is the isolated digital output power supply. Select a proper power supply based on the relay type (see below for the recommended relay). When you use the 24 VDC power supply, it can be also the controller power supply.
- ²⁾ The motor brake can be controlled not only by the brake control signal from the SINAMICS V90 PN servo drive but also by external emergency stop.
- ³⁾ Make sure that you use different power supplies for the brake (24 VDC) and for the brake control signal (P24 V) separately to avoid electro-magnetic interference to electronic components.
- ⁴⁾ Install a varistor as shown above to suppress the surge voltage or surge current generated by an ON/OFF action of the relay (RY).

Varistor (V) used for the power supply of the brake**Note**

All the following data on a varistor is provided based on the low inertia motors with a rated power of 2 kW; however the data is also applicable to the low inertia motors of other power ranges.

4.7 Motor holding brake

Consider the following current-time and voltage-time characteristics when using a varistor to suppress the surge voltage or surge current:

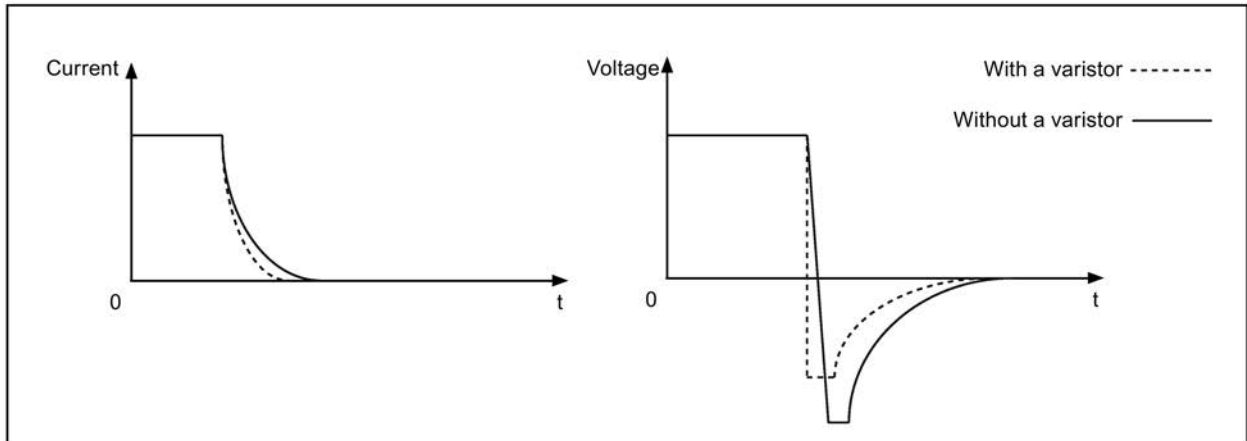

You may select an appropriate varistor with reference to the table below:

Power supply voltage of the brake		DC 24 V
Order information	Manufacturer	EPCOS
	Model	S20K20
Specification requirements	Operating temperature	-20 °C to 60 °C
	Delay switching frequency	< 10 times/min
	Maximum operating DC voltage	26 V
	Average power dissipation	0.2 W
	Voltage at 1 mA	33 V±10%
	Clamping voltage at 20 A (8/20 μs)	65 V
	Energy absorption (2 ms) at a time	18 J

Relay (R) used for the power supply of the brake

Siemens recommends you to select a Siemens relay (article number: 3RQ3018-2AB00).

You can find more information about Siemens relays from Chapter 05 of Catalog IC 10 - SIRIUS 2016 at the following Web site:

Siemens relays

http://w3app.siemens.com/mcms/infocenter/content/en/Pages/order_form.aspx?nodeKey=key_517764&infotype=catalogs

You can also select other high quality relays from manufacturers such as Omron (article number: G2R-1A-E-DC24V) .

Wiring for the 400 V variant servo drive

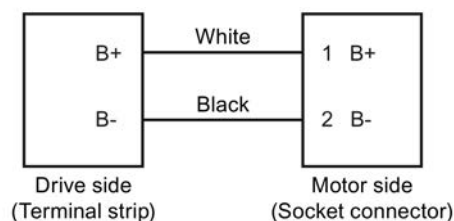

Relevant parameters

No.	Unit	Range	Default	Description
p1215	-	0 to 2	0	Configuration of the holding brake. <ul style="list-style-type: none"> 0: No holding brake available 1: Motor holding brake according to sequence control 2: Motor holding brake always open
p1216	ms	0 to 10000	Motor dependent	Motor holding brake opening time.
p1217	ms	0 to 10000	Motor dependent	Motor holding brake closing time.

You can configure the holding brake with the parameter p1215 according to the actual application. When you set p1215=1, the motor holding brake is open once the control word STW1.0 has a rising edge and becomes closed once the motor is in "servo off" state.

If the servo motor is used to control a vertical axis, the machine movable part can have a slight shift when the holding brake becomes open or closed. To eliminate such slight shift, you can configure a delay time for the close or open time of the motor holding brake by setting the parameters p1216 and p1217.

Note

The default values of p1216 and p1217 depend on the rated power of the motor which connects to the servo drive.

Note

For 200 V variant servo drives, the actual motor holding brake time consists of the time delay of the motor brake and the time delay of the current amplifying component (a relay in the example above); therefore, you can set the values of p1216 and p1217 as follows:

p1216 = motor brake opening time + relay opening time

p1217 = motor brake closing time + relay closing time

NOTICE

Motor brake service life shortened due to the improper use

The motor brake is used for holding purpose only. Frequent emergency stops with the motor brake will shorten its service life.

- Unless absolutely necessary, do not apply the motor brake as an emergency stop or deceleration mechanism.

Braking sequence

The operating principle of the holding brake is configured during motor selection for motors with incremental encoders and configured automatically for motors with absolute encoders.

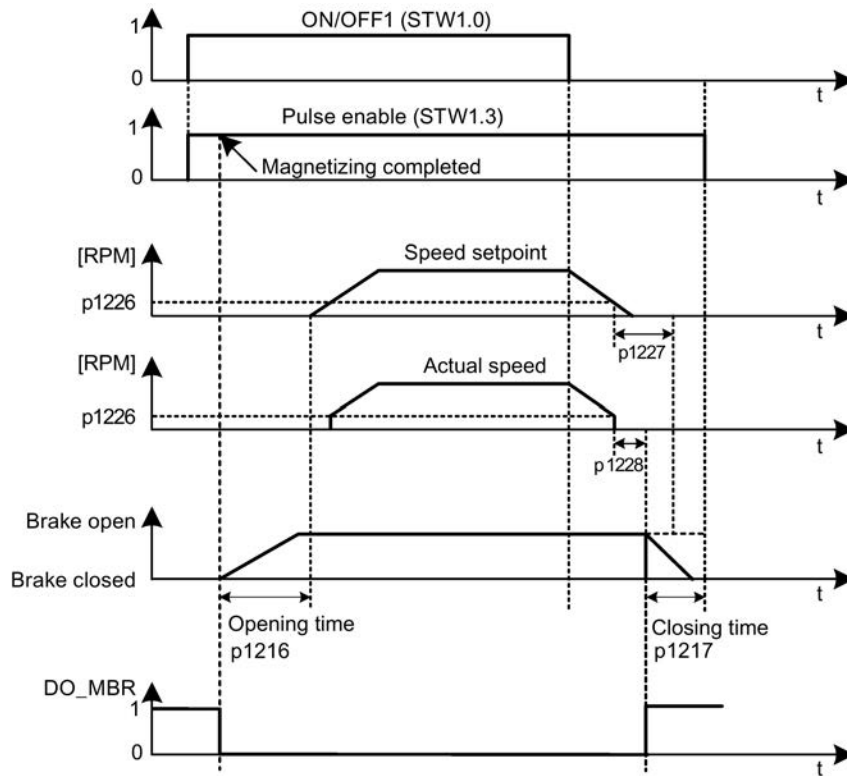

The start of the closing time for the brake depends on the expiration of the shorter of p1227 (zero speed detection monitoring time) and p1228 (pulse suppression delay time).

4.8 PROFINET interface - X150

PROFINET interface

PROFINET devices from the SINAMICS family have a PROFINET interface (Ethernet-controller/interface) with two ports (physical connection possibilities).

Every PROFINET device on the network is uniquely identified via its PROFINET interface. For this purpose, each PROFINET interface has:

- A MAC address (factory default)
- An IP address
- A device name (name of the station)

Illustration	Pin	PROFINET communication port 1 - P1		PROFINET communication port 2 - P2	
		Signal	Description	Signal	Description
	1	P1RXP	Port 1 receive data +	P2RXP	Port 2 receive data +
	2	P1RXN	Port 1 receive data -	P2RXN	Port 2 receive data -
	3	P1TXP	Port 1 transmit data +	P2TXP	Port 2 transmit data +
	4	PE terminal	Protective earthing	PE terminal	Protective earthing
	5	PE terminal	Protective earthing	PE terminal	Protective earthing
	6	P1TXN	Port 1 transmit data -	P2TXN	Port 2 transmit data -
	7	PE terminal	Protective earthing	PE terminal	Protective earthing
	8	PE terminal	Protective earthing	PE terminal	Protective earthing

LED displays

For diagnostic purposes, the RJ45 sockets are each equipped with a green and an orange LED. This allows the following status information about the respective PROFINET port to be displayed:

Name	Color	Status	Meaning
Link	Green	lit	Transfer rate 100 Mbit/s
		off	No or faulty connection
Activity	Orange	lit	Data exchange
		off	No data exchange

Wiring

The maximum length of cables between stations (L1 to Ln) is 100 m. For a long cable, you are recommended to fix it on the cabinet to prevent the connector damage caused by dragging.

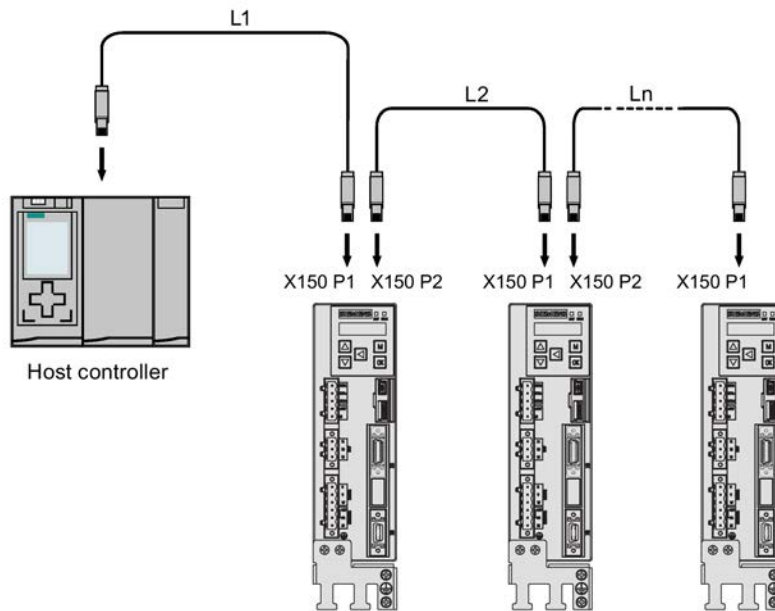

Note

When connecting the ports P1 and P2, you need to make sure that the physical input and output connections are the same with the connections in the topology.

5.1 General commissioning information

Prior to commissioning, read "Basic operator panel (BOP) (Page 131)" for more information about the BOP operations. In case of any faults or alarms during commissioning, refer to Chapter "Diagnostics (Page 283)" for detailed description.

CAUTION

Danger to injury resulting from failure to observe the safety instructions

Failure to observe the instructions can result in serious injuries.

- Before your commissioning or operation, read the safety instructions in Chapter "Fundamental safety instructions (Page 11)" carefully.

WARNING

Material damages and personal injuries by the drop of a hanging axis

When the servo system is used as a hanging axis, the axis will drop if the positive and negative poles of the 24 V power supply are connected inversely. Unexpected drop of the hanging axis may cause material damages and personal injuries.

- Before commissioning, you need to make sure that a crosstie is used to hold the hanging axis in prevention of an unexpected drop. In addition, make sure that the 24 V power supply is correctly connected.

NOTICE

Firmware damage due to drive power-off during data transfer

Switching off the 24 VDC power supply for the drive during data transfer from the micro SD card/SD card to the drive can cause damage to the drive firmware.

- Do not switch off the drive power supply when the data transfer from the micro SD card/SD card to the drive is in process.

NOTICE

Existing setting data is overwritten by the setting data on the micro SD card/SD card during the drive startup

Existing setting data is overwritten by the setting data on the micro SD card/SD card during the drive startup. This situation occurs when a drive is switched on with a micro SD card/SD card containing user setting data, the existing setting data on the drive will be overwritten, or when a drive is switched on with a micro SD card/SD card containing no user setting data, the drive will automatically save the existing user setting data onto the micro SD card/SD card.

- Before starting up the drive with a micro SD card/SD card, check whether the micro SD card/SD card contains user setting data. Otherwise, the existing data on the drive may be overwritten.

Note

Plugging or unplugging the micro SD card/SD card will cause startup failure.

Do not plug or unplug the micro SD card/SD card during startup; otherwise, the drive will fail to start up.

Note

In S control mode, if the motor shaft is blocked, the blocked torque is the current effective torque. Long time shaft blocking can cause damage to the motor.

Engineering tool - SINAMICS V-ASSISTANT

You can use the engineering tool SINAMICS V-ASSISTANT to perform the trial operation.

SINAMICS V-ASSISTANT is a software tool that can be installed on a PC and runs on the Windows operating system. It communicates with the SINAMICS V90 PN servo drive with a USB cable (To ensure the stability of online commissioning, Siemens recommends you to use a shielded USB cable of no longer than 3 m with ferrite cores on both ends.). With SINAMICS V-ASSISTANT, you can change drive parameters and monitor drive working states in online mode.

For more information, refer to the SINAMICS V-ASSISTANT Online Help. You can search and download SINAMICS V-ASSISTANT from Technical support website (<https://support.industry.siemens.com/cs/ww/en/>).

5.2 Commissioning in JOG mode

Commissioning purpose

When the servo drive is powered on for the first time, you can perform a test run with the BOP or the engineering tool SINAMICS V-ASSISTANT to check:

- Whether the line supply has been connected correctly
- Whether the 24 VDC power supply has been connected correctly
- Whether the cables (power cable, encoder cable, and brake cable) between the servo drive and the servo motor have been connected correctly
- Whether the motor speed and direction of rotation are correct

Prerequisites

- The servo drive is connected to the servo motor without load
- The servo drive is not in servo on status

Operating sequence

Note

Set bit 0 of parameter p29108 to 1, and then save the parameter setting and restart the drive, to enable the JOG function; otherwise, you cannot access the function related parameter p1058.

If you have assigned digital signal EMGS, keep it at a high level (1) to ensure normal operation.

Step	Description	Remarks
1	Connect necessary units and check wiring.	<p>It is necessary to connect the following cables:</p> <ul style="list-style-type: none"> • Power cable • Encoder cable • Brake cable • Line supply cable • 24 VDC cable <p>Check:</p> <ul style="list-style-type: none"> • Is the device or cable damaged? • Do the connected cables have excessive pressure, load or tension? • Are the connected cables put on sharp edges? • Is the line supply within the permissible range? • Are all the terminals firmly and correctly connected? • Are all the connected system components well grounded? <p>Refer to "Connecting (Page 91)".</p>
2	Switch on the 24 VDC power supply.	
3	<p>Check the servo motor type.</p> <ul style="list-style-type: none"> • If the servo motor has an incremental encoder, input motor ID (p29000). • If the servo motor has an absolute encoder, the servo drive can identify the servo motor automatically. 	<p>Fault F52984 occurs when the servo motor is not identified.</p> <p>You can find the motor ID from the motor rating plate. Go to "Motor components (Page 28)" for detailed descriptions about motor rating plate.</p> <p>Refer to "Basic operations (Page 139)" for information about how to change a parameter with the BOP.</p>
4	<p>Check the direction of motor rotation.</p> <p>The default direction of rotation is CW (clockwise). You can change it by setting parameter p29001 if necessary.</p>	<p>p29001=0: CW</p> <p>p29001=1: CCW</p>
5	<p>Check the JOG speed.</p> <p>The default JOG speed is 100 rpm. You can change it by setting parameter p1058.</p>	<p>Set bit 0 of parameter p29108 to 1, and then save the parameter setting and restart the drive, to enable the JOG function; otherwise, you cannot access p1058.</p>
6	Save parameters with the BOP.	<p>For detailed information about the parameter saving with the BOP, refer to "Saving parameters (RAM to ROM) (Page 145)".</p>
7	Switch on the main line supply.	
8	Clear faults and alarms.	Refer to "Diagnostics (Page 283)".
9	<p>For the BOP, enter the JOG menu function and press the UP or DOWN button to run the servo motor.</p> <p>For the engineering tool, use the JOG function to run the servo motor.</p>	<p>For more information about JOG with the BOP, see Section "JOG (Page 144)".</p> <p>For more information about JOG with SINAMICS V-ASSISTANT, see the SINAMICS V-ASSISTANT Online Help.</p>

Note

When you run the servo motor with an incremental encoder in JOG mode, the servo motor makes a short buzzing sound indicating that it is identifying the magnetic pole position of the rotor.

5.3 Commissioning in basic positioner control mode (EPOS)

The following takes the EJOG function for example to describe the commissioning in EPOS control mode.

Step	Description	Remarks
1	Switch off the main line supply.	
2	Power off the servo drive and connect it to the controller (for example, SIMATIC S7-1500) with the PROFINET cable and signal cable.	If any one of digital signals EMGS, CWL, and CCWL is not assigned to a DI, it will be set to a high level (1) automatically. If you have assigned any one of digital signals EMGS, CWL, and CCWL to a DI, keep it at a high level (1). Refer to "Standard application wiring (factory setting) (Page 106)" and "Connection example with PLCs (Page 108)".
3	Switch on the 24 VDC power supply.	
4	Check the servo motor type. <ul style="list-style-type: none"> If the servo motor has an incremental encoder, input the motor ID (p29000). If the servo motor has an absolute encoder, the servo drive can identify the servo motor automatically. 	Fault F52984 occurs when the servo motor is not identified. You can find the motor ID from the motor rating plate. For the detailed information of the motor rating plate, see Section "Motor components (Page 28)". Refer to "Basic operations (Page 139)" for information about how to change a parameter with the BOP.
5	Switch to the basic positioner control mode by setting parameter p29003 = 1.	<ul style="list-style-type: none"> p29003 = 1: basic positioner control (EPOS) p29003 = 2: speed control (S)
6	Save the parameter and restart the servo drive to apply the setting of the basic positioner control mode.	
7	Set the mechanical gear ratio with parameters p29247, p29248 and p29249.	<ul style="list-style-type: none"> p29247: LU per load revolution p29248: load revolutions p29249: motor revolutions Refer to "Setting the mechanical system (Page 162)".
8	Select the axis type by setting parameter p29245. If you use the modular axis, you need to define the modular range by setting parameter p29246.	<ul style="list-style-type: none"> p29245 = 0: linear axis p29245 = 1: modular axis Refer to "Configuring the linear/modular axis (Page 163)".
9	Setting jogging setpoints with the appropriate parameters. <ul style="list-style-type: none"> Velocity (p2585, p2586) Incremental (p2587, p2588) 	Refer to "EJOG (Page 181)".
10	Switch on the main line supply.	
11	Set up the PROFINET configuration with TIA Portal.	
12	Select the telegram for PROFINET communication with parameter p0922.	

5.4 Commissioning in speed control mode (S)

Step	Description	Remarks
1	Switch off the main line supply.	
2	Power off the servo drive and connect it to the controller (for example, SIMATIC S7-1500) with the PROFINET cable and signal cable.	<p>If any one of digital signals EMGS, CWL, and CCWL is not assigned to a DI, it will be set to a high level (1) automatically.</p> <p>If you have assigned any one of digital signals EMGS, CWL, and CCWL to a DI, keep it at a high level (1).</p> <p>Refer to "Standard application wiring (factory setting) (Page 106)" and "Connection example with PLCs (Page 108)".</p>
3	Switch on the 24 VDC power supply.	
4	<p>Check the servo motor type.</p> <ul style="list-style-type: none"> • If the servo motor has an incremental encoder, input the motor ID (p29000). • If the servo motor has an absolute encoder, the servo drive can identify the servo motor automatically. 	<p>Fault F52984 occurs when the servo motor is not identified.</p> <p>You can find the motor ID from the motor rating plate. Go to "Motor components (Page 28)" for detailed descriptions about motor rating plate.</p> <p>Refer to "Basic operations (Page 139)" for information about how to change a parameter with the BOP.</p>
5	Set up the PROFINET configuration with TIA Portal.	
6	Select the telegram for PROFINET communication with parameter p0922.	
7	Set the IP address for the station with parameters p8921, p8923.	
8	Set the device name for the station with parameter p8920.	The device name must be unique within the PROFINET network.
9	Active the IP configuration and device name with parameter p8925.	
10	Set the torque limitation and speed limitation.	Refer to "Torque limit (Page 184)" and "Speed limit (Page 183)".
11	<p>Configure necessary digital input signals by setting the following parameters:</p> <ul style="list-style-type: none"> • p29301: DI1 • p29302: DI2 • p29303: DI3 • p29304: DI4 	<p>The factory settings are:</p> <ul style="list-style-type: none"> • p29301: 2 (RESET) • p29302: 11 (TLIM) • p29303: 0 • p29304: 0 <p>Refer to "Digital inputs/outputs (DIs/Dos) (Page 102)".</p>
12	Save parameters with the BOP and restart the drive.	
13	Switch on the main line supply.	
14	Clear faults and alarms.	Refer to "Diagnostics (Page 283)".
15	Send and receive the process data (PZD) with TIA Portal.	<p>The actual speed of the servo motor can be viewed from the BOP operating display.</p> <p>The default display is the actual speed.</p> <p>Refer to "Actual status display (Page 138)".</p>

Basic operator panel (BOP)

6.1 BOP overview

Overview

The SINAMICS V90 PN servo drive is designed with a Basic Operator Panel (BOP) on the front panel of the servo drive:

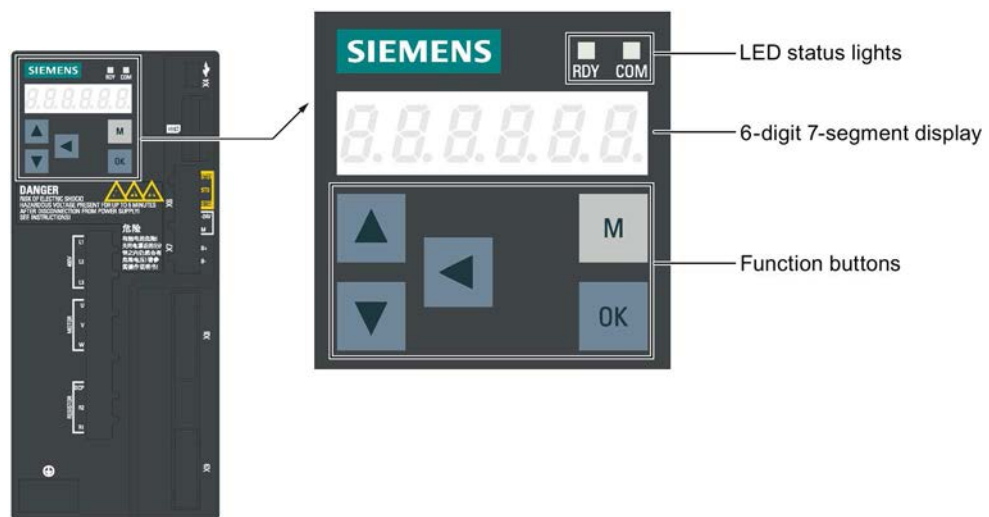

You can use the BOP for the following operations:

- Standalone commissioning
- Diagnosis
- Parameter access
- Parameter settings
- Micro SD card/SD card operations
- Drive restart

6.1.1 LED status indicators



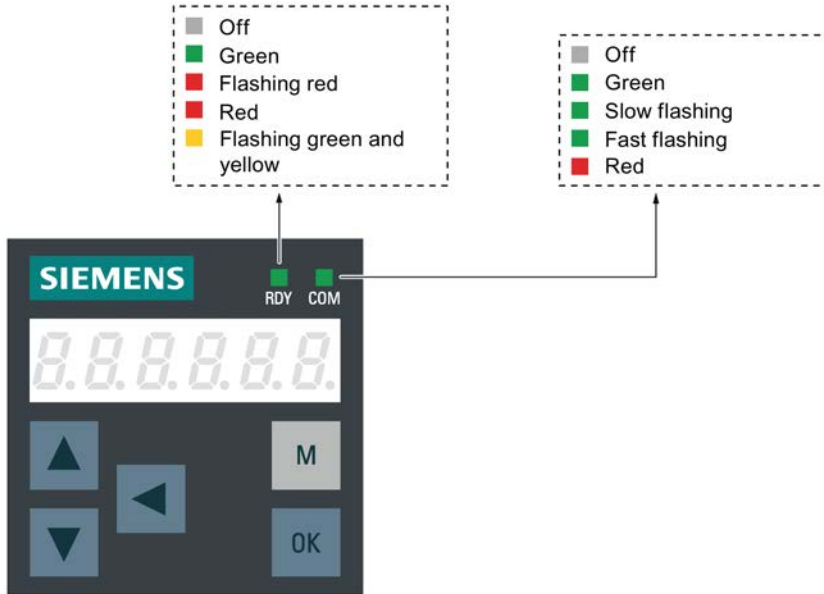







Two LED status indicators (RDY and COM) are available to indicate drive status. Both LEDs are tricolor (green/red/yellow).

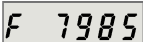
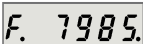
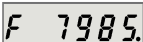





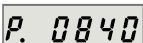

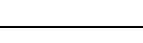
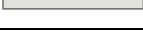
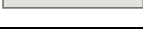
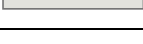

You can find detailed information about the status indications in the table below:

Status indicator	Color	Status	Description
RDY	-	Off	24 V control board power supply is missing
	Green	Continuously lit	The drive is in "servo on" state
	Red	Continuously lit	The drive is in "servo off" state or in the startup state
		Flash at 1 Hz	Alarms or faults occurs
	Green and yellow	Flash alternatively at 2 Hz	Drive identification
COM	Green	Continuously lit	PROFINET communication is working with IRT
		Flash at 0.5 Hz	PROFINET communication is working with RT
		Flash at 2 Hz	Micro SD card/SD card operating (read or write)
	Red	Continuously lit	Communication error (always put the PROFINET communication error as the first consideration)

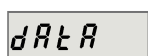
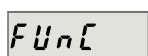
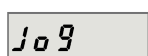
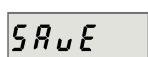
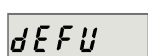
6.1.2 BOP display

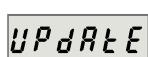
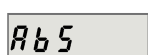
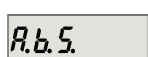
Display	Example	Description	Remarks
8.8.8.8.8.8.		Drive is in startup state	
-----		Drive is busy	
Fxxxxx		Fault code	In the case of a single fault
F.xxxxx.		Fault code of the first fault	In the case of multiple faults
Fxxxxx.		Fault code	In the case of multiple faults
Axxxxx		Alarm code	In the case of a single alarm
A.xxxxx.		Alarm code of the first alarm	In the case of multiple alarms
Axxxxx.		Alarm code	In the case of multiple alarms
Rxxxxx		Parameter number	Read-only parameter
Pxxxxx		Parameter number	Editable parameter
P.xxxxx		Parameter number	Editable parameter; the dot means that at least one parameter has been changed
In xxx		Indexed parameter	Figure after "In" indicates the number of indices. For example, "In 001" means that this indexed parameter is 1.
xxx.xxx		Negative parameter value	
xxx.xx<>		Current display can be moved to left or right	
xxxx.xx>		Current display can be moved to right	
xxxx.xx<		Current display can be moved to left	









6.1 BOP overview

Display	Example	Description	Remarks
S Off		Operating display: servo off	
Para		Editable parameter group	Refer to the section "Editing parameters (Page 140)".
P xxxx		Parameter group	Five groups are available: 1. P APP : application 2. P BASE : basic 3. P CON : communication 4. P EPOS : basic positioner 5. P ALL : all parameters
Data		Read-only parameter group	Refer to "Viewing parameters (Page 142)".
Func		Function group	Refer to "Auxiliary functions (Page 143)".
Jog		Jog function	Refer to "JOG (Page 144)".
Save		Save data in drive	Refer to "Saving parameters (RAM to ROM) (Page 145)".
defu		Restore drive to default settings	Refer to "Setting parameters to default (Page 146)".
dr--sd		Save data from drive to micro SD card/SD card	Refer to "Transferring data (drive to SD) (Page 146)".
sd--dr		Upload data from micro SD card/SD card to drive	Refer to "Transferring data (SD to drive) (Page 147)".
Update		Update firmware	Refer to "Updating firmware (Page 148)".
ABS		The zero position has not been set	Refer to "Adjusting an absolute encoder (Page 149)".
A.B.S.		The zero position has been set	Refer to "Adjusting an absolute encoder (Page 149)".
r xxx		Actual speed (positive direction)	
r -xxx		Actual speed (negative direction)	
T x.x		Actual torque (positive direction)	

Display	Example	Description	Remarks
T -x.x		Actual torque (negative direction)	
xxxxxx		Actual position (positive direction)	Only the last six digits displays due to a limited display length.
xxxxxx.		Actual position (negative direction)	Only the last six digits displays due to a limited display length.
DCxxx.x		Actual DC link voltage	
Exxxxx		Position following error	
run		The motor is running	
Con		The communication between the commissioning tool SINAMICS V-ASSISTANT and the servo drive is established. In this case, the BOP is protected from any operations except clearing alarms and acknowledging faults.	

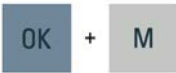
6.1.3 Control buttons

Control buttons

Button	Description	Functions
	M button	<ul style="list-style-type: none"> Exits from the current menu Switches between operating modes in the top level menu
	OK button	<p>Short-pressing:</p> <ul style="list-style-type: none"> Confirms selection or input Enters sub menu Acknowledges faults <p>Long-pressing:</p> <p>Activates auxiliary functions</p> <ul style="list-style-type: none"> JOG Saves parameter set in drive (RAM to ROM) Sets parameter set to default Transfers data (drive to micro SD card/SD card) Transfers data (micro SD card/SD card to drive) Updates firmware
	UP button	<ul style="list-style-type: none"> Navigates to the next item Increases a value JOG in CW (clockwise)
	DOWN button	<ul style="list-style-type: none"> Navigates to the previous item Decreases a value JOG in CCW (counter-clockwise)
	SHIFT button	<p>Moves the cursor from digit to digit for single digit editing, including the digit of positive/negative sign</p> <p>Note: When the sign is edited, "_" indicates positive and "-" indicates negative.</p>
	Press the key combination for four seconds to restart the drive	
	Moves current display to the left page when  is displayed at the upper right corner, for example <i>00.000r</i> .	
	Moves current display to the right page when  is displayed at the lower right corner, for example <i>00 10l</i> .	

6.2 Parameter structure

The overall parameter structure of SINAMICS V90 PN BOP is designed as follows:

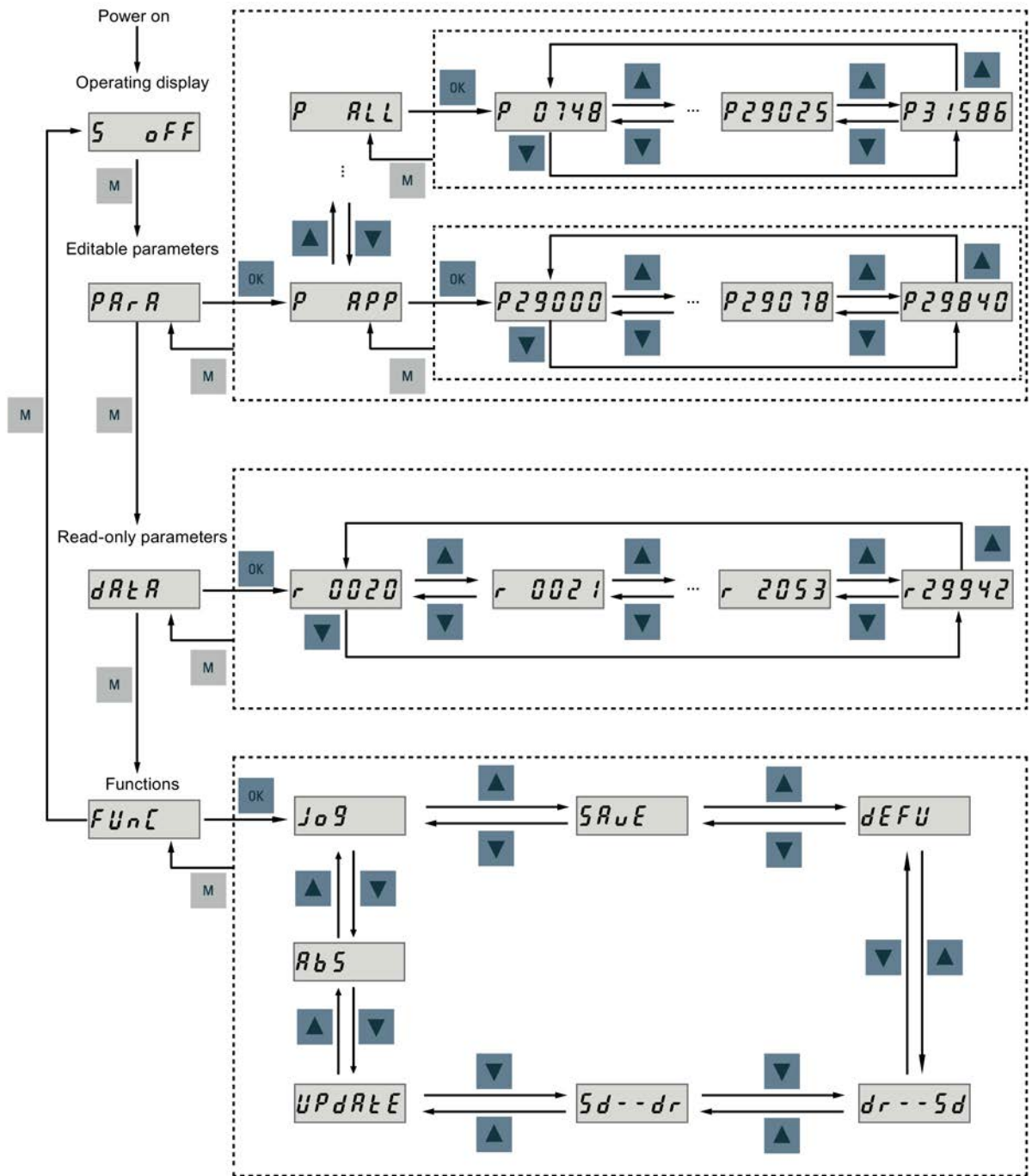

Note

There is no ABS menu function for a servo motor with an incremental encoder.

The ABS menu function is **only** available for a servo motor with an absolute encoder.

6.3 Actual status display

The following drive states can be monitored using the operating panel after power-on:

- Servo off
- Actual speed
- Actual torque
- DC voltage
- Actual position
- Position following error

If servo enable signal is available, actual drive speed is displayed by default; otherwise, "S OFF" (servo off) is displayed.

With p29002, you define which of the following drive operating status data is to be displayed on the BOP:

Parameter	Value	Meaning
p29002	0 (default)	Actual speed
	1	DC voltage
	2	Actual torque
	3	Actual position
	4	Position following error

Note

Make sure you save p29002 after modification.

6.4 Basic operations

Overview

- Editable parameters: all **P** parameters under the "**Para**" menu are settable parameters. Five groups in total are available:
 - **P APP**: application
 - **P BASE**: basic
 - **P COM**: communication
 - **P EPOS**: basic positioner
 - **P ALL**: all parameters
- Read-only parameters: All **r** parameters under the "**Data**" menu are read-only parameters. You can only read values of these parameters.

Parameters with index

Some parameters have several indices. Each index has its own meaning and corresponding value.

Parameters without index

All parameters that do not have indices are parameters without index.

6.4.1 Editing parameters

You can edit a parameter value in two methods:

- Method 1: change the value directly with the UP or DOWN button

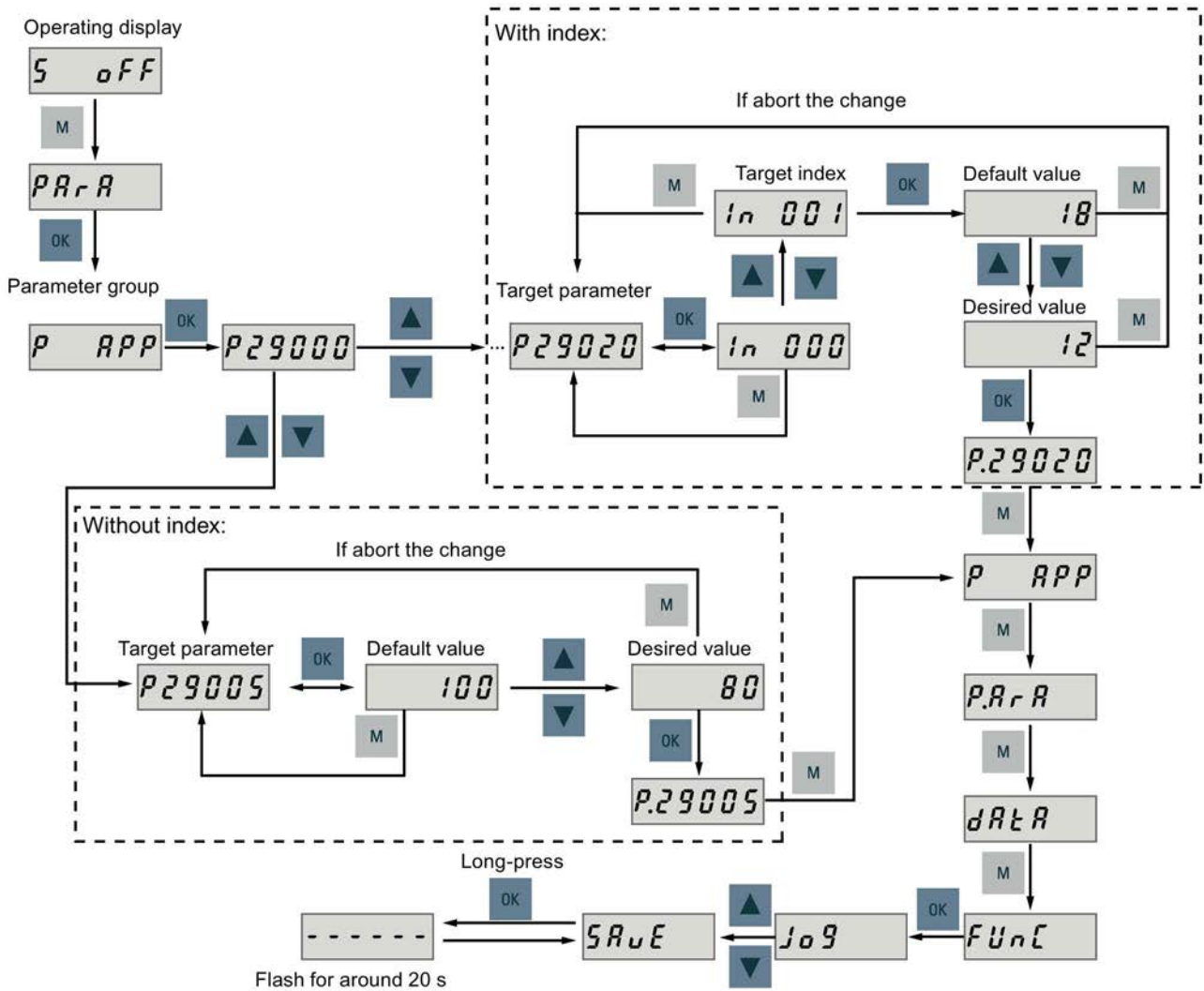

- Method 2: move the cursor to a digit with the **SHIFT** button, then change the digit value with the **UP** or **DOWN** button

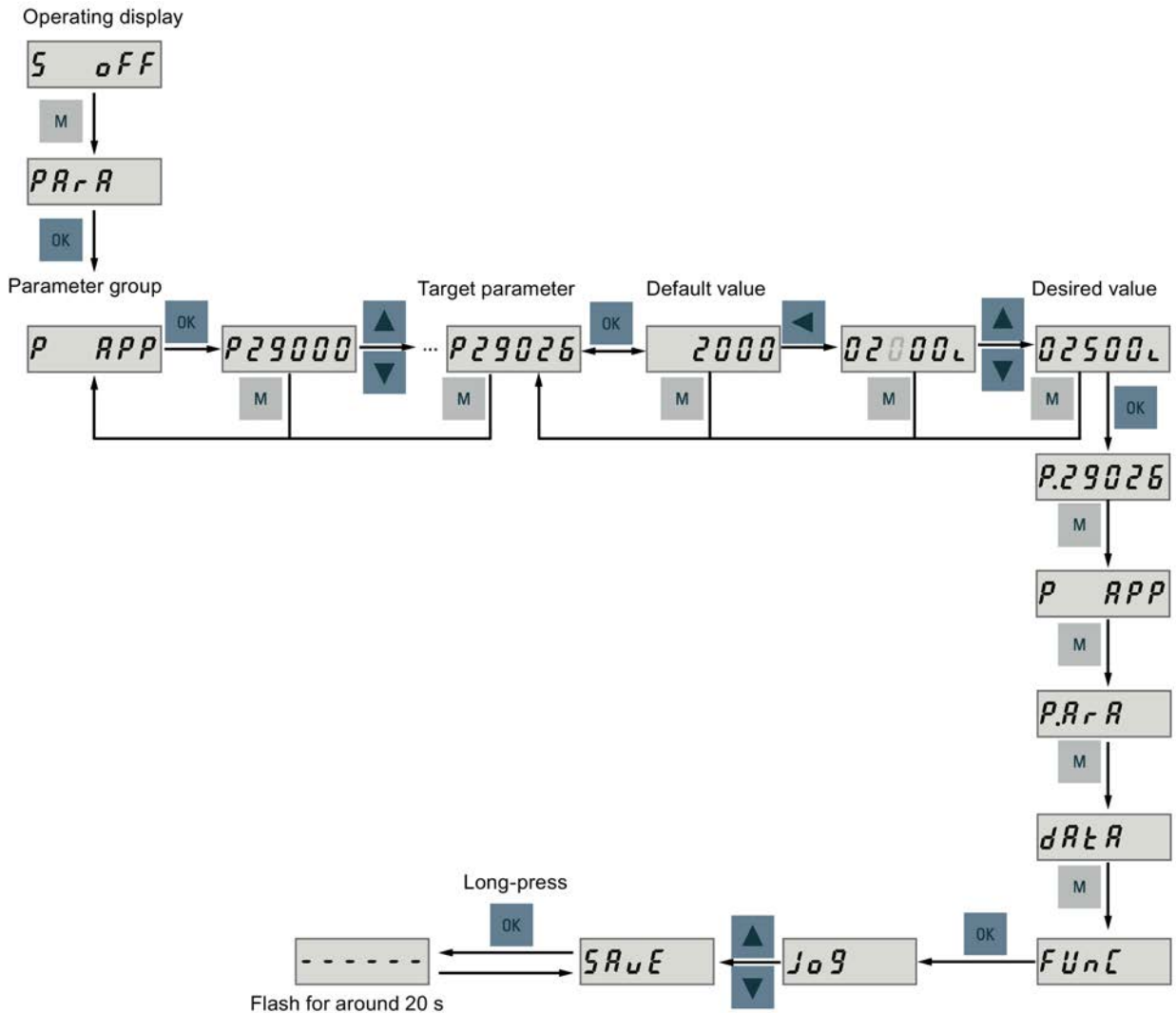

Note

Parameters p1414 and p1656 cannot be changed using the **SHIFT** button.

6.4.2 Viewing parameters

To view a parameter, proceed as follows:

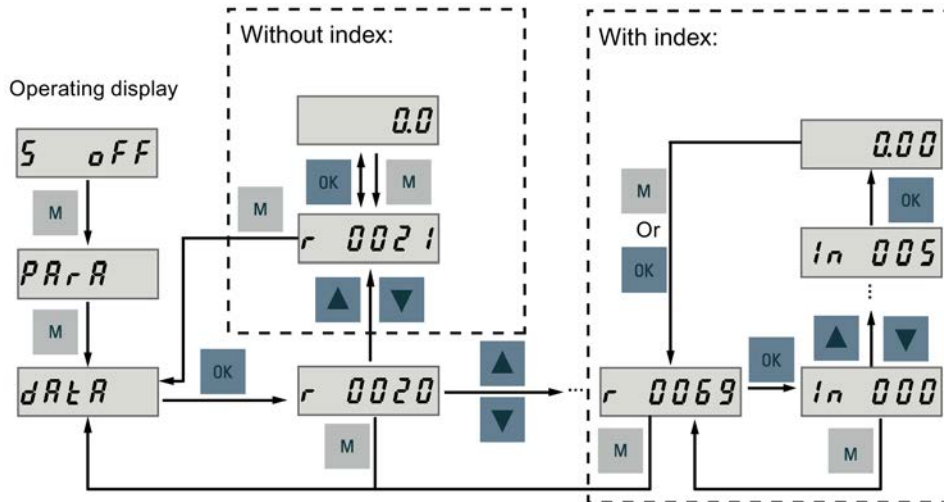

6.4.3 Searching parameters in "P ALL" menu

If you do not know which group that a parameter belongs to, you can search for in the "P ALL" menu.

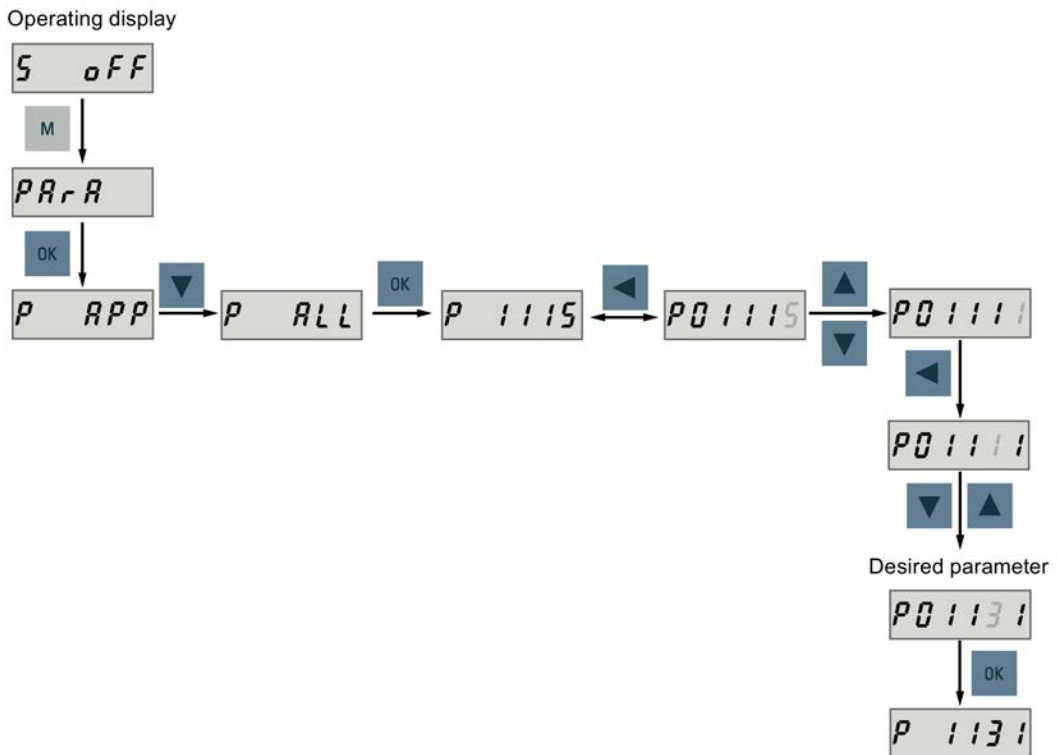

Note**Invalid parameter number**

If the input parameter number is unavailable, the nearest parameter number to the input value is displayed.

6.5 Auxiliary functions

In total, there are six BOP functions available:

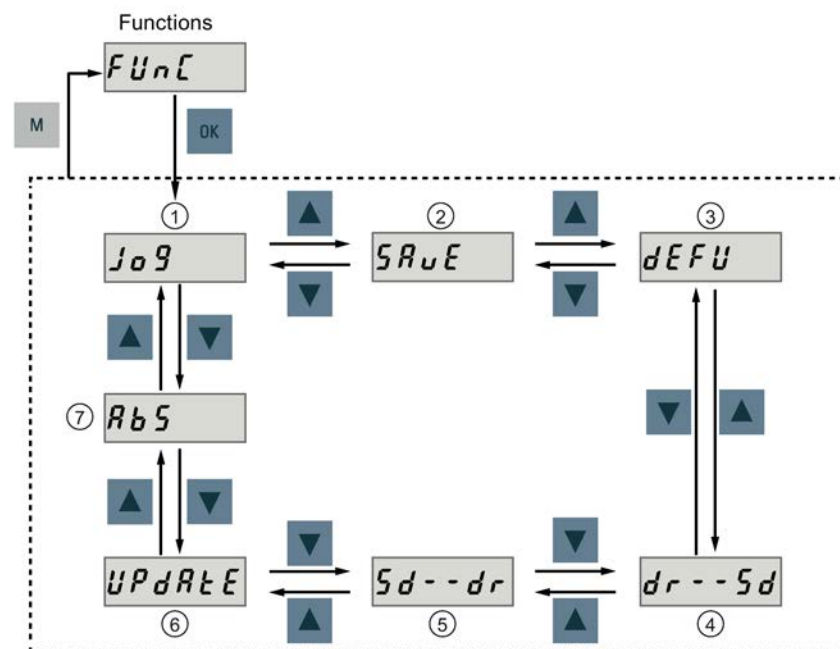

- ① Jog
- ② Save parameter set in drive
- ③ Restore parameter values to default
- ④ Copy parameter set from a drive to a micro SD card/SD card
- ⑤ Copy parameter set from a micro SD card/SD card to a drive
- ⑥ Update firmware
- ⑦ Adjust absolute encoder

NOTE:

This function is available only when the servo motor with an absolute encoder is connected.

6.5.1 JOG

Note

To enable the JOG function, set bit 0 of parameter p29108 to 1, and then save the parameter setting and restart the drive.

Keep digital signal EMGS at a high level (1) to ensure normal operation.

With the JOG function, you can run the connected motor and view JOG speed or JOG torque.

To run the connected motor with the JOG function and view the JOG speed, proceed as follows:

JOG in speed (example)

To run the connected motor with the JOG function and view the JOG torque, proceed as follows:

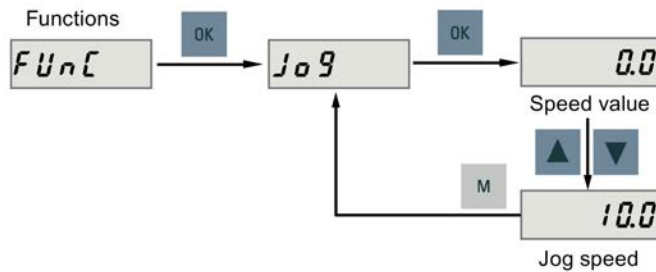

JOG in torque (example)

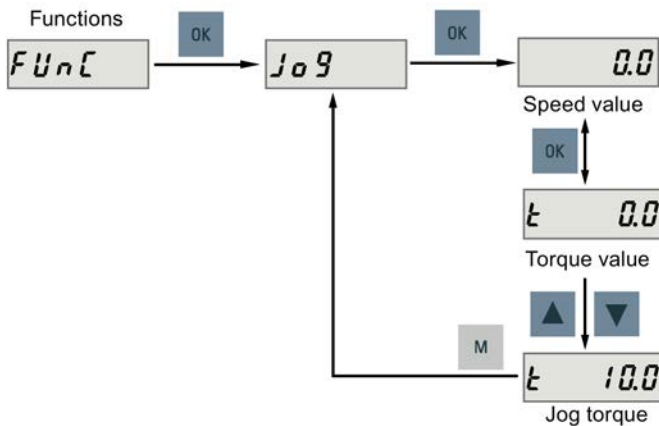

NOTICE
Exit the JOG mode after completing JOG run.
The servo motor cannot run if the servo drive is in the JOG mode.

6.5.2 Saving parameters (RAM to ROM)

This function is used for saving a parameter set from the drive RAM to the drive ROM.

To use this function, proceed as follows:

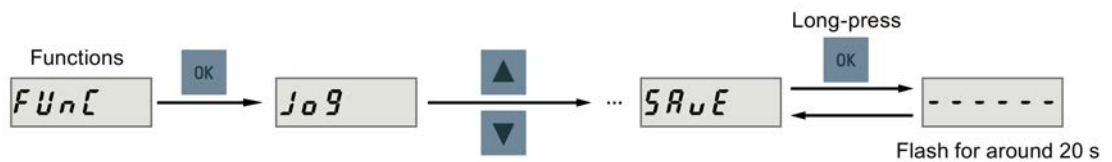

Note

Plugging or unplugging the micro SD card/SD card will cause saving failure.

Do not plug or unplug the micro SD card/SD card during saving; otherwise, the saving operation will fail.

Note

- If a micro SD card/SD card has been inserted, the parameter set will be saved onto the micro SD card/SD card simultaneously.
 - All signal functions become inactive during the saving process. Use the signal functions afterwards.
-

Reference

Editing parameters (Page 140)

6.5.3 Setting parameters to default

This function is used to reset all parameters to their default values.

To reset the parameters to their default values, proceed as follows:

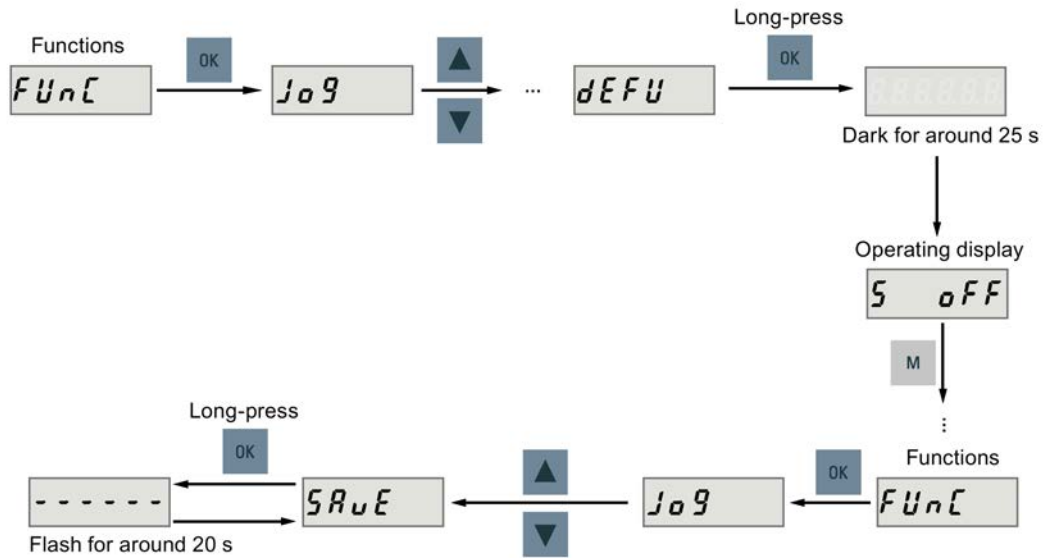

Note

You **must** save the parameter set after setting the parameter set to the default values; otherwise, the default values will not be saved to drive ROM.

Reference

Saving parameters (RAM to ROM) (Page 145)

6.5.4 Transferring data (drive to SD)

You can save the parameter set from the drive ROM to a micro SD card/SD card with the BOP. To do this, proceed as follows:

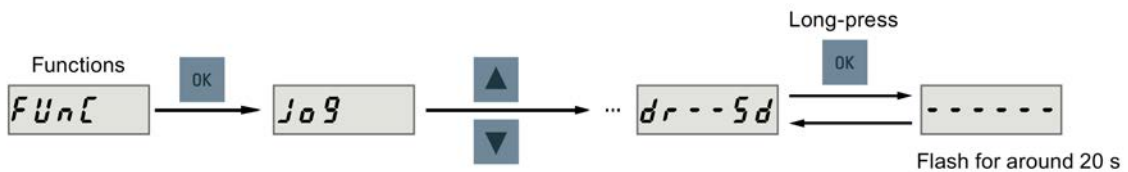

Note

Data transfer between the drive and the SD card is possible only when the drive is in "servo off" state.

Note

Plugging or unplugging the micro SD card/SD card will cause transferring failure.

Do not plug or unplug the micro SD card/SD card during transferring; otherwise, the transferring operation will fail.

Note

Write protection function is not supported by SINAMICS V90 PN. Data in the micro SD card/SD card will be overwritten even if the write protection function of the micro SD card/SD card is enabled.

6.5.5 Transferring data (SD to drive)

You can also upload the parameters from a micro SD card/SD card to the drive ROM. To do this, proceed as follows:

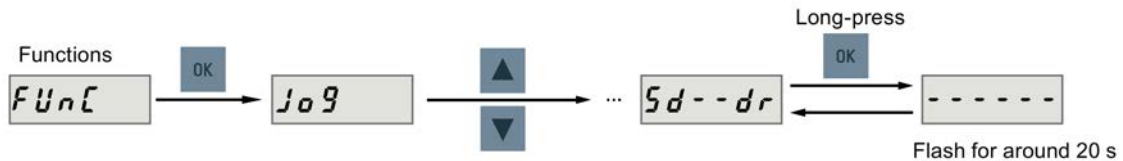
**Note**

Data transfer between the drive and the SD card is possible only when the drive is in "servo off" state.

Note

Plugging or unplugging the micro SD card/SD card will cause transferring failure.

Do not plug or unplug the micro SD card/SD card during transferring; otherwise, the transferring operation will fail.

Note**Parameter inconsistency**

If the parameters on the micro SD card/SD card are inconsistent with existing parameters in the drive memory, you **must** restart the servo drive to apply the changes.

6.5.6 Updating firmware

With the firmware update function of the BOP, you can update the drive firmware. To do this, you have to store proper firmware files on a micro SD card/SD card and insert it into the micro SD card/SD card slot. After that, proceed as follows:

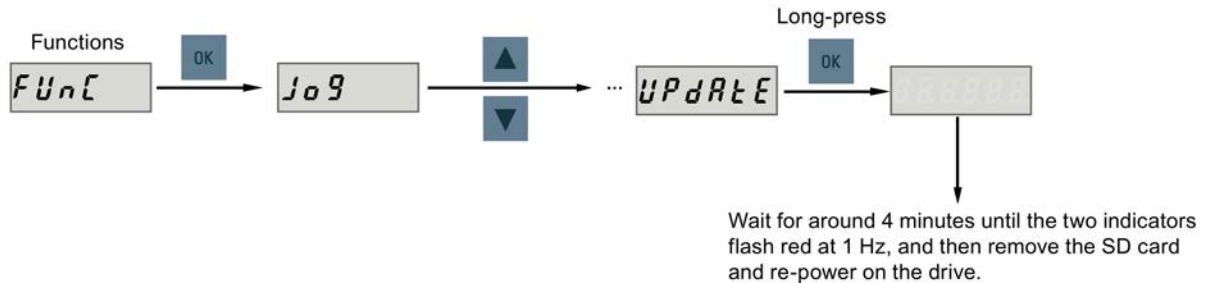

After you have updated the firmware, you need to set parameters to their default values. Refer to "Setting parameters to default (Page 146)" about the default process.

Note

Before you update the firmware, you can back up the drive data on a micro SD card/SD card. If you want to use them after the update, you can copy the data from the micro SD card/SD card to the drive (Page 147).

CAUTION

Update failure due to improper firmware files

An update failure can be caused by improper firmware files or files missing. When the update fails, the RDY indicator flashes red at 2 Hz and the COM indicator becomes red on. If the firmware files on the micro SD card/SD card are corrupt, the servo drive **cannot** start up after power-on. If the firmware on the micro SD card/SD card is the same with the current firmware of the servo drive, **only** a restart is performed.

- Try to update the firmware again using proper firmware files. If the failure persists, contact your local distributor.

Note

Update the firmware by restarting the drive.

After inserting the micro SD card/SD card with proper firmware files, you can also update the firmware by restarting the drive.

6.5.7 Adjusting an absolute encoder

Note

Motor type

This function is **only** available when you are using a servo motor with the absolute encoder.

Stop the servo motor

You must stop the servo motor before adjusting the absolute encoder.

With the BOP function menu "**ABS**", you can set the current position of an absolute encoder to the zero position. To do this, proceed as follows:

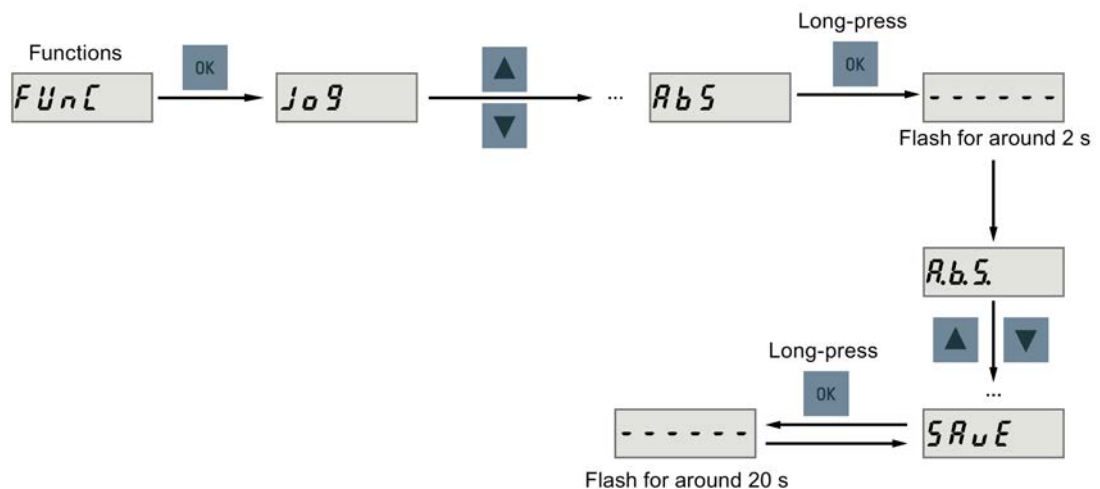

Note

Save parameter



The position value is set in parameter p2525. You **must** save the parameters after setting the zero position.

Control functions

7.1 General functions

7.1.1 Motor direction of rotation

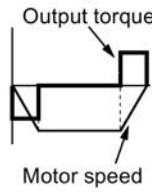
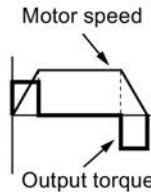
With parameter p29001, you can reverse the direction of rotation of the motor. The polarity of output signal analog monitoring remains unchanged at a reversal of direction.

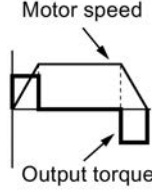
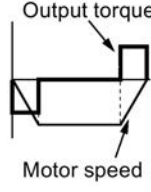
Parameter	Value	Description	Setpoint	
			Positive	Negative
p29001	0	CW is forward direction (factory setting) 	<ul style="list-style-type: none"> Analog monitoring: 	<ul style="list-style-type: none"> Analog monitoring: 
	1	CCW is forward direction 	<ul style="list-style-type: none"> Analog monitoring: 	<ul style="list-style-type: none"> Analog monitoring: 

7.1.2 Stopping method at servo OFF

You can select a stopping method when the drive is in "servo off" state. The following stopping methods are available:

- Ramp-down (OFF1)
- Coast-down (OFF2)
- Emergency stop (OFF3)

Ramp-down (OFF1) and coast-down (OFF2)

The ramp-down and coast-down can be configured with the PROFINET control words STW1.0 and STW1.1:

Ramp-down (OFF1)

Control word	Setting	Description
STW1.0	Rising edge (0→1)	Power circuit is powered on (the drive is in "servo on" state) and the servo motor is ready to run.
	0	Motor ramps down.

Note:

The control word STW1.0 can be used to control the start and stop of the motor.

Coast-down (OFF2)

Control word	Setting	Description
STW1.1	1	Servo motor is ready to run.
	0	Motor coasts down.

Emergency stop (OFF3)

The emergency stop can be configured with the PROFINET control word STW1.2 or the digital input signal EMGS:

Emergency stop by PROFINET control word

Control word	Setting	Description
STW1.2	1	Servo motor is ready to run.
	0	Emergency stop.

Emergency stop by digital input signal

DI Signal	Setting	Description
EMGS	1	Servo motor is ready to run.
	0	Emergency stop.

For detailed information about the PROFINET control word and the digital input signal EMGS, refer to Section "Control word definition (Page 193)" and "Digital inputs/outputs (DIs/Dos) (Page 102)".

7.1.3 Travel to fixed stop

The function can be used to move the motor to a fixed stop at a specified torque without a fault being signaled. The specified torque is built up and remains applied after the motor reaches the fixed stop.

The desired torque derating is brought about by scaling the upper torque limit and the lower torque limit.

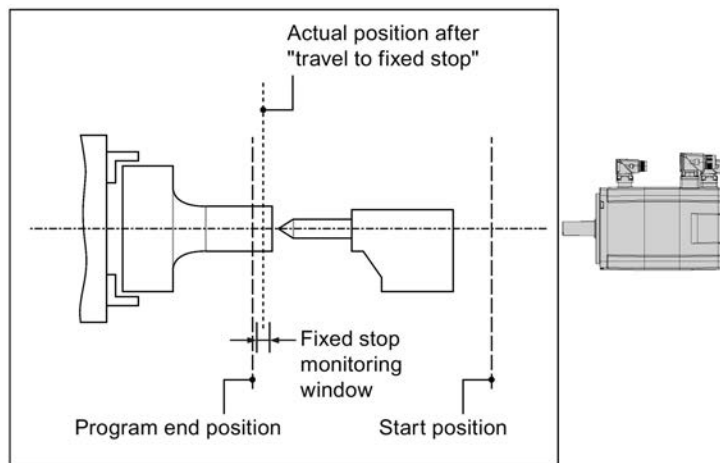

Function behavior in speed (S) control mode

When SINAMICS V90 PN is working in the speed (S) control mode, the "travel to fixed stop" function can be used in all the telegrams except the standard telegram 1, because the function through telegram is part of STW2 and ZSW2 and they are not included in standard telegram 1.

The function can be enabled by the PROFINET control word STW2.8 and the drive status can be indicated by the status word ZSW2.8:

Control word	Value	Description
STW2.8	1	Activation of the "travel to fixed stop" function
	0	De-activation of the "travel to fixed stop" function

Status word	Value	Description
ZSW2.8	1	Travel to fixed stop reached
	0	No "travel to fixed stop" status

When PROFINET telegrams 2, 3, and 5 are used, no torque reduction is transferred. When the "Travel to fixed stop" function is activated, the motor ramps up to the torque limits.

When PROFINET telegrams 102 and 105 are used, the torque can be reduced by the control word MOMRED.

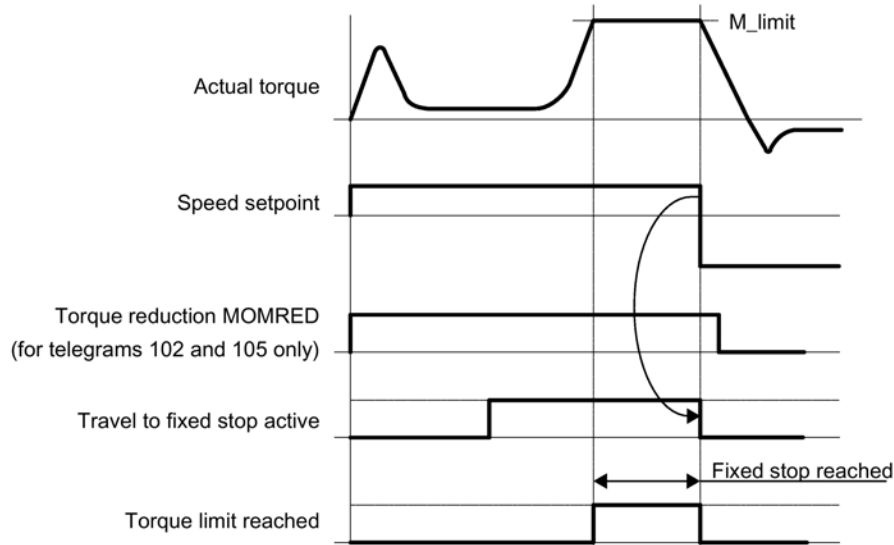

Example

This example shows the operating procedures when you use the "Travel to fixed stop" function in S control mode.

Prerequisites:

Use a 0.4 kW low inertia motor (rated torque = 1.27 Nm)

Procedures:

1. Set the STW2.8 = 1 to enable the "Travel to fixed stop" function.
2. Set the required torque limit. The smaller value of the following two torque limits will be the active one.

Example

Internal torque limit TLM:

- p29050[0] = 300 → Positive torque limit
- p29051[0] = -300 → Negative torque limit

Overall torque limit:

- p1520 = 100 Nm → Positive overall torque limit
- p1521 = -150 Nm → Negative overall torque limit

3. Set the torque reduction by control word MOMRED (for telegrams 102 and 105 only).
When the torque reduction function is used, the calculation of actual torque limit value is shown as follows:

$$\text{Actual torque limit value} = \text{Torque limit} \times (1 - \text{percentage of reference torque})$$

Example

- In this example, the active torque limit is the internal torque limit TLM (torque limit = 300% × rated torque)
- MOMRED = 3600 hex (13824 dec)

$$\text{Actual torque limit value} = 300\% \times 1.27 \text{ Nm} \times (1 - 13824/16384) = 0.5953 \text{ Nm}$$

4. Servo on the motor and it traverses to the fixed stop.
The motor runs at the set speed until it reaches the stop and continues to work against the stop until the torque limit has been reached.
For telegrams 2, 3, and 5, the torque limit status can be indicated in status word ZSW1.11. For telegrams 102 and 105, this status can be indicated in status word MELDW.1.

Function behavior in basic positioner (EPOS) control mode

When the drive is working in EPOS traversing block mode, if a traversing block is processed with the FIXED STOP command (p2621[0...15] = 2), the function starts. You can set the required clamping torque of the FIXED STOP function by the task parameter p2622[0...15]. An adjustable monitoring window for travel to fixed stop prevents the drive from traveling beyond the window if the fixed stop should break away. For more information about setting parameters in the traversing block, see Section "Traversing blocks (Page 172)".

Parameter	Range	Value	Description
p2621[0...15]	1 to 9	1 (default)	POSITIONING
		2	FIXED STOP
		3	ENDLESS_POS
		4	ENDLESS_NEG
		5	WAITING
		6	GOTO
		7	SET_O
		8	RESET_O
		9	JERK

You can set the additional data depending on the different traversing block task by the parameter p2622:

Parameter	Description
p2622[0...15]	FIXED STOP: Clamping torque and clamping force (rotary 0...65536 [0.01 Nm])
	WAITING: Delay time [ms]
	GOTO: Block number
	SET_O: 1, 2 or 3 - set direct output 1, 2 or 3 (both)

Parameter	Description
	RESET_O: 1, 2 or 3 - reset direct output 1, 2 or 3 (both)
	JERK: 0 - deactivate; 1 - activate

From the start position onwards, the target position is approached with the parameterized speed (p2618). The fixed stop (the workpiece) must be between the start position and the braking point of the axis; that is, the target position is placed inside the workpiece. The preset torque limit is effective from the start, i.e. travel to fixed stop also occurs with a reduced torque. The preset acceleration and deceleration overrides and the current speed override are also effective.

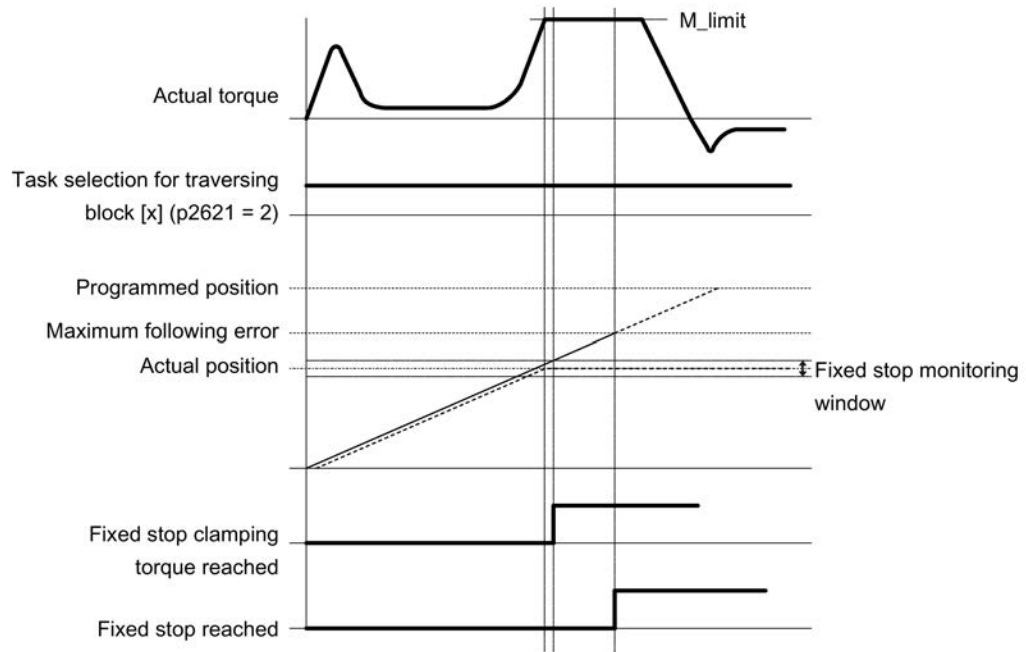

Note

F7452 is disabled when the function of travelling to fixed stop is activated.

Fixed stop is reached

As soon as the axis comes into contact with the mechanical fixed stop, the closed-loop control in the drive raises the torque so that the axis can move on. The torque increases up to the value specified in the task and then remains constant. If the actual position following error exceeds the value set in parameter p2634 (fixed stop: maximum following error), fixed stop is reached.

Once the "Fixed stop reached" status has been detected, the traversing task "Travel to fixed stop" is ended. The program advances to the next block depending on the task parameterization. The drive remains in fixed stop until the next positioning task is processed or the system is switched to jog mode. The clamping torque is therefore also applied during subsequent waiting tasks. The continuation condition CONTINUE_EXTERNAL_WAIT can be used to specify that the drive must remain at the fixed stop until a step enabling signal is applied externally.

As long as the drive remains in fixed stop, the position setpoint is adjusted to the actual position value (position setpoint = actual position value). Fixed stop monitoring and controller enable are active.

Note

If the drive is in fixed stop, it can be referenced using the control signal "Set reference point".

If the axis leaves the position that has been detected as the fixed stop by more than the selected monitoring window for the fixed stop (p2635), the speed setpoint is set to 0, and fault F7484 "Fixed stop outside of the monitoring window" is triggered with the reaction OFF3 (quick stop). The monitoring window can be set using the parameter p2635 ("Fixed stop monitoring window"). It applies to both positive and negative traversing directions and must be selected such that it will only be triggered if the axis breaks away from the fixed stop.

Fixed stop is not reached

If the brake application point is reached without the "fixed stop reached" status being detected, then the fault F7485 "Fixed stop is not reached" is output with fault reaction OFF1, the torque limit is canceled and the drive cancels the traversing block.

Related parameters

- p2617[0...15] EPOS traversing block, position
- p2618[0...15] EPOS traversing block, velocity
- p2619[0...15] EPOS traversing block, acceleration override
- p2620[0...15] EPOS traversing block, deceleration override
- p2621[0...15] EPOS traversing block task
- p2622[0...15] EPOS traversing block task parameter
- p2634 EPOS fixed stop maximum following error
- p2635 EPOS fixed stop monitoring window

For more information about parameters above, see Section "Parameter list (Page 247)".

Example

This example shows the operating procedures when you use the "Travel to fixed stop" function in EPOS control mode.

Prerequisites:

Use a 0.4 kW low inertia motor (rated torque = 1.27 Nm)

Procedures:

1. Configure the PLC and V90 PN drive. Select the telegram 111.
2. Set the target position of traversing block 0.

p2617[0] = 10000

3. Configure the traversing task to be "FIXED STOP".
p2621[0] = 2
4. Set the torque limit to 0.1 Nm.
p2622[0] = 10
5. Set the maximum following error by p2634 and the monitoring window by p2635.
6. Perform referencing.

Note:

When the SINAMICS V90 PN is working in EPOS traversing block mode, referencing must be performed before moving the axis.

7. After the drive performs referencing successfully, trigger traversing block 0 by control word STW1.6.
8. Observe the drive status to check whether the fixed stop is reached.

Fixed stop is reached:

- If the actual position following error exceeds the value set in parameter p2634, fixed stop is reached.

Fixed stop is not reached:

- After the fixed stop is reached, if the axis leaves the fixed stop and exceeds the monitoring window (p2635), the speed setpoint is set to 0, and fault F7484 occurs
 - If the brake application point is reached without the "fixed stop reached" status being detected, then the fault F7485 occurs
9. Once the "Fixed stop reached" status has been detected, the traversing task "Travel to fixed stop" is ended. The program advances to the next block depending on the task parameterization.

7.1.4 Position tracking

The position tracking function can be used to realize the following features:

- Setting up a virtual multi-turn for a single-turn absolute encoder
- Extending the position area
- Enabling the load position to be reproduced when using gearboxes

If the position tracking function is enabled, the actual position value can be saved in a power-off retentive memory when you power off the drive. When you power on the drive again, the saved position value can be read by the drive.

Virtual multi-turn encoder

For a single-turn absolute encoder with position tracking activated ($p29243 = 1$), $p29244$ can be used to enter a virtual multi-turn resolution. This enables you to generate a virtual multi-turn encoder value from a single-turn encoder. The actual position value in $r2521$ is limited to 2^{32} places.

- When position tracking is deactivated ($p29243 = 0$):
Encoder actual position value range = actual single-turn resolution
- When position tracking is activated ($p29243 = 1$):
Encoder actual position value range = actual single-turn resolution \times virtual multi-turn resolution ($p29244$)

Tolerance window

The tolerance window is preset to a quarter of one encoder revolution. After switching on the drive, the difference between the saved position and the actual position is determined. Based on the difference, the following situations apply:

- Difference being within the tolerance window:
The position is reproduced based on the actual encoder value.
- Difference exceeding the tolerance window:
The fault F7449 (for EPOS control mode) is output.

NOTICE

Multi-turn position loss resulting from the axis movement when the drive is power-off

When the drive is power-off, if the axis moves, the drive does not store the multi-turn position (when using the virtual multi-turn encoder). The actual position loses.

- Make sure that the motor holding brake function is enabled when you use the position tracking function.

Position area extension

After the position tracking function is activated, the position area can be extended.

Example

An absolute encoder that can represent eight encoder revolutions is used here.

- If the position tracking function is deactivated ($p29243 = 0$), the position for ± 4 encoder revolutions can be reproduced.
- If you activate the position tracking function ($p29243 = 1$), and set the virtual multi-turn $p29244 = 24$, and the gear ratio $p29248/p29249 = 1$, the position for ± 12 encoder revolutions (± 12 load revolutions with load gear) can be reproduced.

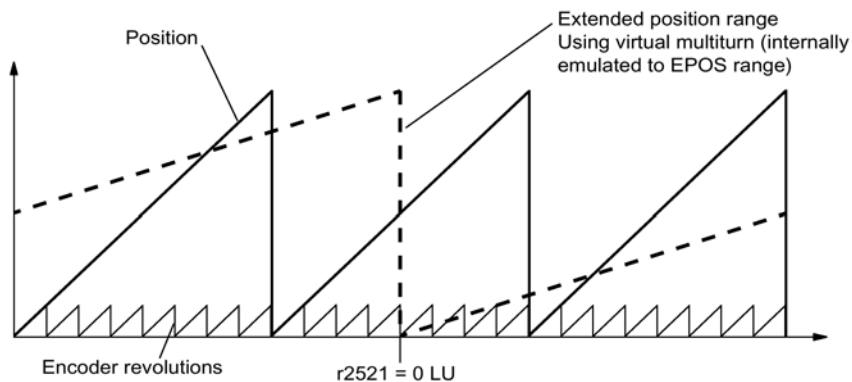

Mechanical gear configuration

If you are using a mechanical gear between the motor and the load, and using an absolute encoder to process the position control, an offset occurs (depending on the gear ratio) between the zero position of the encoder and the load whenever encoder overflow occurs.

Note

If the ratio between the multi-turn resolution and the modulo range (p29246) is not an integer number, fault F7442 is output.

To make the ratio between the multi-turn resolution and the modulo range an integer number, observe the following formulas. The ratio v is calculated as follows:

- Motor encoder without position tracking (p29243 = 0):
 - For multi-turn encoders:

$$v = (4096 \times p29247 \times p29248) / (p29249 \times p29246)$$
 - For single-turn encoders:

$$v = (p29247 \times p29248) / (p29249 \times p29246)$$
- Motor encoder with position tracking (p29243 = 1):

$$v = (p29244 \times p29247) / p29246$$

Example

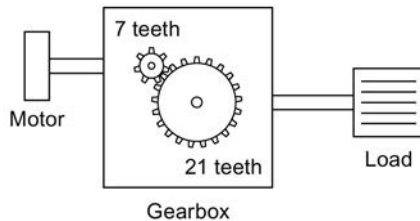

- Gear ratio = p29248 : p29249 = 1 : 3
- The absolute encoder can count eight encoder revolutions
- Position tracking function is deactivated (p29243 = 0)

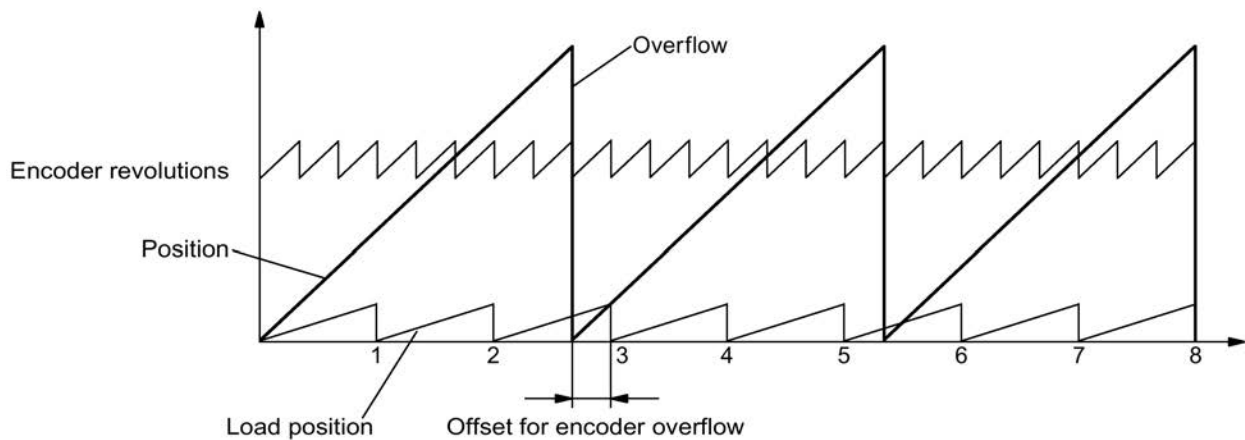

For each encoder overflow, there is a load-side offset of $1/3$ load revolution, after three encoder overflows, the motor and load zero position coincide again. The position of the load can no longer be clearly reproduced after one overflow.

In this case, if you activate the position tracking function (set $p29243 = 1$), and set the virtual multi-turn $p29244 = 24$, the gear ratio is calculated with the encoder actual position value.

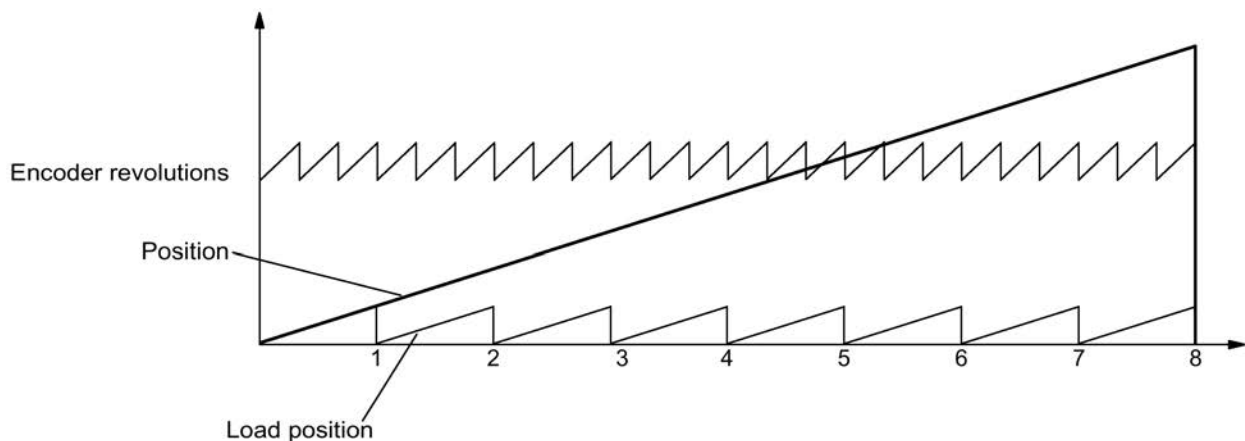

Note

Be sure to perform the "ABS" function again after you set $p29243$ to 1.

Overview of important parameters

- $p29243$ Position tracking activate
- $p29244$ Absolute encoder virtual rotary revolutions
- $p29248$ Mechanical gear: Numerator
- $p29249$ Mechanical gear: Denominator
- $r2521[0]$ LR position actual value

7.2 Basic positioner (EPOS)

7.2.1 Setting the mechanical system

By parameterizing the mechanical system, the link between the physical moving part and the length unit (LU) is established.

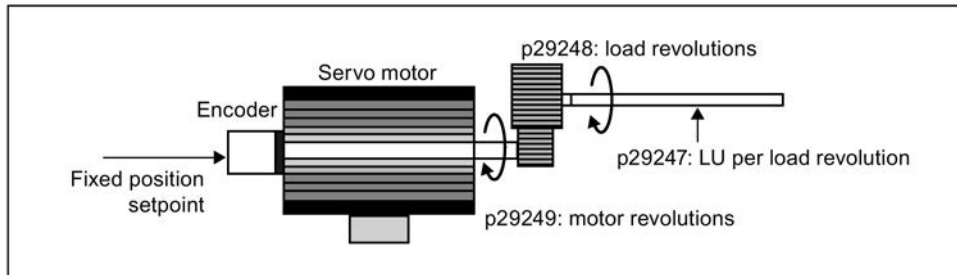

The unit of the fixed position setpoint is the Length Unit (LU). All subsequent position setpoint, related speed value, and acceleration value will maintain the LU as the unit in internal position control mode.

Taking a ball screw system for example, if the system has a pitch of 10 mm/revolution (10000 μm /revolution) and the resolution of the length unit is 1 μm (1 LU = 1 μm), one load revolution corresponds to 10000 LU (p29247 = 10000).

Note

If the value of p29247 increases by N times, the values of p2542, p2544 and p2546 should increase by N times accordingly. Otherwise, the fault F7450 or F7452 occurs.

Relevant parameters

Parameter	Range	Factory setting	Unit	Description
p29247	1 to 2147483647	10000	-	LU per load revolution
p29248	1 to 1048576	1	-	Load revolutions
p29249	1 to 1048576	1	-	Motor revolutions

Examples for configuring mechanical system

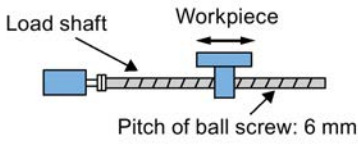
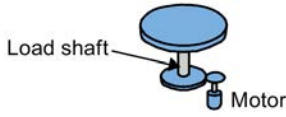
Step	Description	Mechanical system		
		Ball screw	Disc table	
				
1	Identify the mechanical system	<ul style="list-style-type: none"> Pitch of ball screw: 6 mm Reduction gear ratio: 1:1 	<ul style="list-style-type: none"> Rotary angle: 360° Reduction gear ratio: 3:1 	
2	Define LU	1 LU = 1 μm	1 LU = 0.01°	
3	Calculate the LU per load shaft revolution	6/0.001 = 6000 LU	360/0.01 = 36000 LU	
4	Set parameters	p29247	6000	36000
		p29248	1	1
		p29249	1	3

7.2.2 Configuring the linear/modular axis

You can choose to use a linear axis or a modular axis depending on your actual application. The linear axis has a restricted traversing range, which is the factory setting of the SINAMICS V90 PN servo drive.

The modular axis has an unrestricted traversing range. The value range of the position repeats itself after a value is specified in p29245. You can use the modular axis by setting the following parameters additionally:

Parameter	Range	Unit	Default	Description
p29245	0 to 1	-	0	<ul style="list-style-type: none"> 0: linear axis 1: modular axis
p29246	1 to 2147482647	LU	360000	Modular range

Note

After modifying parameter p29245, you must perform the referencing operation again.

7.2.3 Backlash compensation

Generally, backlash occurs when the mechanical force is transferred between a machine part and its drive:

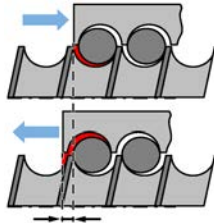

Backlash: p2583

If the mechanical system was to be adjusted/designed so that there was absolutely no backlash, this would result in high wear. Thus, backlash can occur between the machine component and the encoder. For axes with indirect position sensing, mechanical backlash results in a false traversing distance because the axis, at direction reversal, travels either too far or not far enough corresponding to the absolute value of the backlash.

Note

Pre-conditions for backlash compensation

The backlash compensation is active after

- the axis has been referenced for the incremental measuring system. Refer to Section "Referencing (Page 167)" for detailed information about referencing.
- the axis has been adjusted for the absolute measuring system. Refer to Section "Adjusting an absolute encoder (Page 149)" for reference.

In order to compensate the backlash, the determined backlash must be specified in p2583 with correct polarity. At each direction of rotation reversal, the axis actual value is corrected dependent on the actual traversing direction.

If the axis has been referenced or adjusted, the setting of parameter p2604 (reference point approach, starting direction) is used to activate the compensation value:

p2604	Traversing direction	Activate compensation value
0	Negative	Immediately
1	Positive	Immediately

Parameter settings

Parameter	Range	Unit	Default	Description
p2583	-200000 to 200000	LU	0	Backlash compensation
p2604 ¹⁾	0 to 1	-	0	Set signal source for start direction of searching cam: <ul style="list-style-type: none"> • 0: start in positive direction • 1: start in negative direction

¹⁾ When telegram 111 is used, the value of p2604 is assigned by control word POS_STW2.9.

7.2.4 Over-travel

When the servo motor travels over the distance limit, the limit switch is turned on and then the servo motor has an emergency stop.

When telegram 111 is used, the over-travel function can be configured with the PROFINET control word POS_STW2.15:

Control word	Setting	Description
POS_STW2.15	1	STOP cam active.
	0	STOP cam inactive.

Travel limit signal (CWL/CCWL)

In EPOS control mode, the motor rotates properly after you do as follows:

- When F7492 is triggered after the STOP cam plus is reached in a positive traversing direction, acknowledge the fault using the RESET signal, and then move the axis away from the STOP cam plus in a negative traversing direction to return it to a position within the valid traversing range.
- When F7491 is triggered after the STOP cam minus is reached in a negative traversing direction, acknowledge the fault using the RESET signal, and then move the axis away from the STOP cam minus in a positive traversing direction to return it to a position within the valid traversing range.

Note

- Make sure both signals CWL and CCWL are at a high level when the servo drive is powered on.
- In EPOS control mode, the motor cannot rotate with F7491/F7492 being triggered again, if you only acknowledge the fault without returning the axis to a position within the valid traversing range.

Signal CWL functions as the clockwise travel limit while signal CCWL functions as the counter-clockwise travel limit. Both of them are level and edge sensitive signals.

Signal type	Signal name	Pin assignment	Setting	Description
DI	CWL	X8-a (a = 1 to 4)	Falling edge (1→0)	The servo motor has travelled to the clockwise travel limit and has an emergency stop after that.
DI	CCWL	X8-b (b = 1 to 4; b ≠ a)	Falling edge (1→0)	The servo motor has travelled to the counter-clockwise travel limit and has an emergency stop after that.

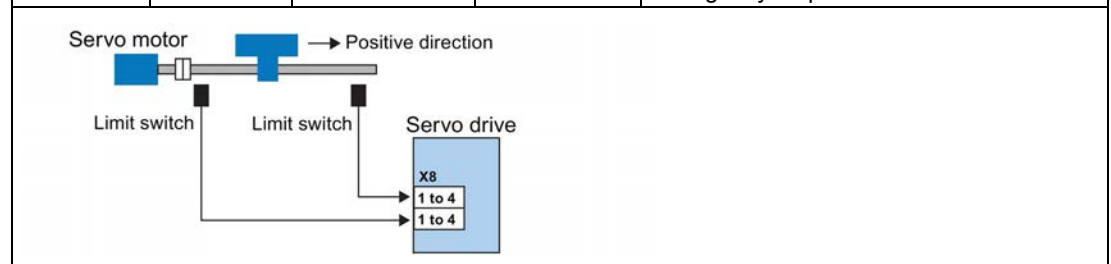

Relevant parameter settings

Parameter	Value setting	Description
p29301 to p29304	3	Signal CWL (signal number: 3) is assigned to any one of DI1 to DI4.
p29301 to p29304	4	Signal CCWL (signal number: 4) is assigned to any one of DI1 to DI4.

When either of signals CWL and CCWL is not assigned to any DI, the signal will be at a high level automatically.

Note

DI parameterization

Refer to Section "Digital inputs/outputs (DIs/Dos) (Page 102)" for detailed information about DI parameterization.

Refer to Chapter "Parameters (Page 245)" for detailed information about parameters.

7.2.5 Software position limit

The following two software position limits are available in the internal position control mode:

- positive position limit
- negative position limit

The function of the software position limit only becomes active after the referencing operation is performed. When the actual position reaches one of the above-mentioned software position limits, the motor decelerates to 0.

When telegram 111 is used, the software position limit function can be configured with the PROFINET control word POS_STW2.14:

Control word	Setting	Description
POS_STW2.14	1	Software limit switch activation.
	0	Software limit switch deactivation.

Parameter settings

Parameter	Range	Factory setting	Unit	Description
p2580	-2147482648 to 2147482647	-2147482648	LU	Negative software position limit switch
p2581	-2147482648 to 2147482647	2147482648	LU	Positive software position limit switch
p2582	0 to 1	0	-	Activation of software limit switch: <ul style="list-style-type: none"> • 0: deactivate • 1: activate

7.2.6 Speed limit

Refer to Section "Speed limit (Page 183)" for details.

7.2.7 Torque limit

Refer to Section "Torque limit (Page 184)" for details.

7.2.8 Referencing

Referencing modes

When telegrams 7, 9, 110, and 111 are used, starting referencing can be configured with the PROFINET control word STW1.11:

Control word	Setting	Description
STW1.11	1	Start referencing.
	0	Stop referencing.

If the servo motor has an incremental encoder, totally three referencing modes are available:

- Setting reference point with the digital input signal REF
- External reference cam (signal REF) and encoder zero mark
- Encoder zero mark only

If the servo motor has an absolute encoder, the three referencing modes are available. You can also adjust the absolute encoder (by setting current position as the zero position) with the BOP function "ABS". Refer to Section "Adjusting an absolute encoder (Page 149)" for details.

You can select one of these referencing modes by setting the parameter p29240:

Parameter	Value	Description
p29240	0	Referencing with external signal REF
	1 (default)	Referencing with external reference cam (signal REF) and encoder zero mark
	2	Referencing with zero mark only

Note

Referencing mode for absolute encoder

If an absolute encoder is connected, the three referencing modes are available. You can select the different referencing modes with parameter p29240. When p29240 = 1 or 2, the referencing process can only be implemented before you use the "ABS" function. Once the "ABS" function is implemented, the two referencing modes are not available any more.

Setting reference point with the digital input signal REF (p29240=0)

When telegram 111 is used, the digital input signal REF can be configured with the PROFINET control word POS_STW2.1:

Control word	Setting	Description
POS_STW2.1	1	Set reference point.
	0	Do not set reference point.

When telegram 110 is used, the digital input signal REF can be configured with the PROFINET control word POS_STW.1:

Control word	Setting	Description
POS_STW.1	1	Set reference point.
	0	Do not set reference point.

When telegrams 7 and 9 are used, the digital input signal REF can be configured with digital inputs.

Note

Preconditions for this referencing mode

- The servo motor must be in "servo on" state and keep standstill.
- The signal REF must be OFF under the following conditions:
 - before power-on
 - when switching from another referencing mode to this referencing mode
 - when switching from another control mode to basic positioner control mode

Note

When setting the reference point via the digital input REF, you need to keep the control word STW1.11 = 0.

The current position is set to zero at a rising edge of the signal REF and the servo drive is referenced:

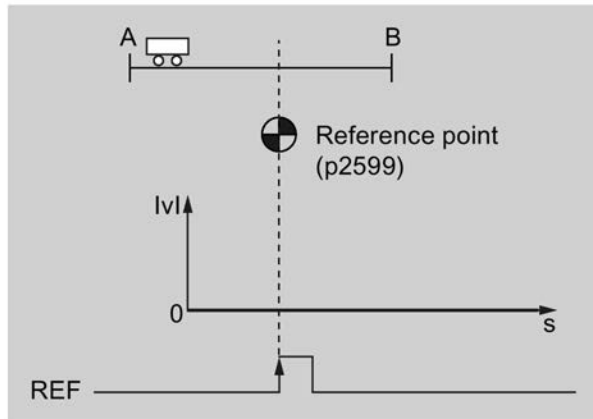

⚠ CAUTION

The referencing point may not be fixed during referencing.

The servo motor must be in "servo on" state so that the referencing point is fixed during referencing.

External reference cam (signal REF) and encoder zero mark (p29240=1)

When telegram 111 is used, the digital input signal REF can be configured with the PROFINET control word POS_STW2.2:

Control word	Setting	Description
POS_STW2.2	1	Reference cam active.
	0	Reference cam inactive.

When telegram 110 is used, the digital input signal REF can be configured with the PROFINET control word POS_STW.2:

Control word	Setting	Description
POS_STW.2	1	Reference cam active.
	0	Reference cam inactive.

When telegrams 7 and 9 are used, the digital input signal REF can be configured with digital inputs.

The referencing is triggered by control word STW1.11. After that, the servo motor accelerates to the speed specified in p2605 to find the reference cam. The direction (CW or CCW) for searching the reference cam is defined by p2604. When the reference cam is reached (signal REF: 0→1), the servo motor decelerates to standstill. After that, the servo motor accelerates again to the speed specified in p2608 and the running direction is opposite to the direction defined by p2604. Then the signal REF should be switched off (1→0). When the servo motor reaches the first zero mark, it starts to travel towards the reference point defined in p2600 with the speed specified in p2611. When the servo motor reaches the reference point (p2599), the signal REFOK is output. Set STW1.11 to 0 and the referencing finishes successfully.

The whole process is shown in the diagram below:

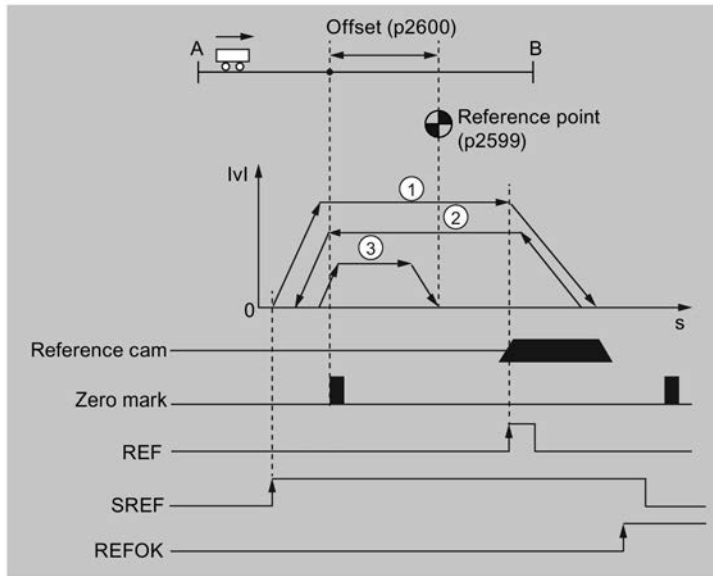

- ① Speed for searching the cam (p2605)
- ↓
- ② Speed for searching zero mark (p2608)
- ↓
- ③ Speed for searching reference point (p2611)

Follow the steps below to perform referencing with this mode:

1. Set relevant parameters:

Parameter	Range	Factory setting	Unit	Description
p2599	-2147482648 to 2147482647	0	LU	Sets the position value for the reference point coordinate.
p2600	-2147482648 to 2147482647	0	LU	Reference point offset
p2604 ¹⁾	0 to 1	0	-	Sets signal source for start direction of searching: <ul style="list-style-type: none"> • 0: start in positive direction • 1: start in negative direction
p2605	1 to 40000000	5000	1000 LU/min	Speed for searching the cam
p2606	0 to 2147482647	2147482647	LU	Maximum distance for searching the cam
p2608	1 to 40000000	300	1000 LU/min	Speed for searching zero mark
p2609	0 to 2147482647	20000	LU	Maximum distance for searching the zero mark
p2611	1 to 40000000	300	1000 LU/min	Speed for searching reference point

¹⁾ When telegram 111 is used, the value of p2604 is assigned by control word POS_STW2.9.

2. Configure signal REF.
Refer to Section "Digital inputs/outputs (DIs/Dos) (Page 102)" for reference.
3. Set STW1.11 (0→1) to start referencing.

Note

During the referencing, if STW1.11 is set to 0, the referencing stops.

4. If the servo motor reaches the reference point, the signal REFOK (if configured) is output.
5. Set control word STW1.11 to 0, and the referencing finishes successfully.

Encoder zero mark only (p29240=2)

In this mode, there is no cam available. The referencing is triggered by control word STW1.11. After that, the servo motor accelerates to the speed specified in p2608 and the direction (CW or CCW) is defined by p2604. When the servo motor reaches the first zero mark, it starts to travel towards the reference point defined in p2600 with the speed specified by p2611. When the servo motor reaches the reference point (p2599), the signal REFOK is output. Set control word STW1.11 to 0 and the referencing finishes successfully.

The whole process is shown in the diagram below:

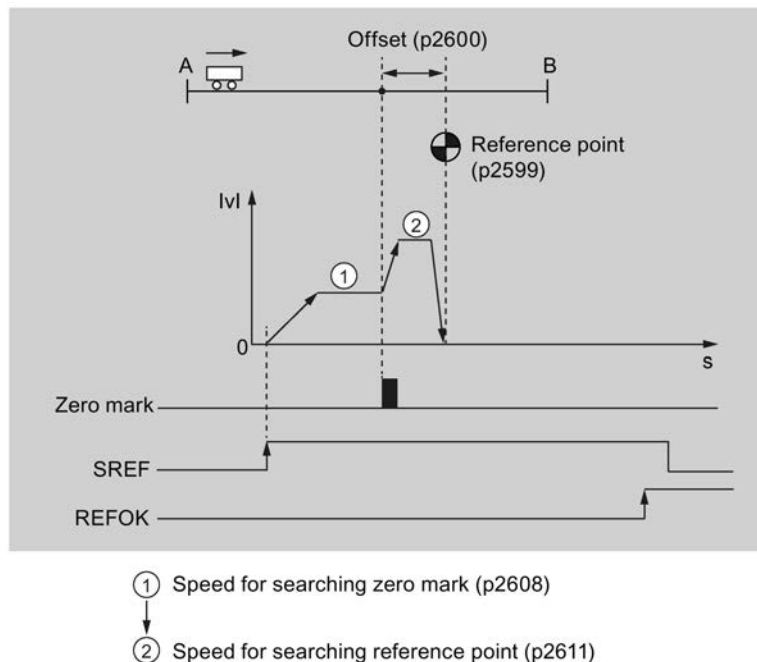

Follow the steps below to perform referencing with this mode:

1. Set relevant parameters:

Parameter	Range	Factory setting	Unit	Description
p2599	-2147482648 to 2147482647	0	LU	Sets the position value for the reference point coordinate.
p2600	-2147482648 to 2147482647	0	LU	Reference point offset
p2604	0 to 1	0	-	Sets signal source for start direction of searching: <ul style="list-style-type: none"> • 0: start in positive direction • 1: start in negative direction
p2608	1 to 40000000	300	1000 LU/min	Speed for searching zero mark
p2609	0 to 2147482647	20000	LU	Maximum distance for searching the zero mark
p2611	1 to 40000000	300	1000 LU/min	Speed for searching reference point

2. Set STW1.11 (0→1) to start referencing.

Note

During the referencing, if STW1.11 is set to 0, the referencing stops.

3. If the servo motor reaches the reference point, the signal REFOK (if configured) is output.
4. Set control word STW1.11 to 0, and the referencing finishes successfully.

7.2.9 Traversing blocks

Up to 16 different traversing tasks can be saved. All parameters which describe a traversing task are effective during a block change.

Activating the traversing block function

When telegram 111 is used, the traversing block function can be configured with the PROFINET control word POS_STW1.15:

Control word	Setting	Description
POS_STW1.15	1	MDI selection.
	0	Traversing block selection.

When telegrams 7, 9, and 110 are used, the traversing block function can be configured with the PROFINET control word SATZANW.15:

Control word	Setting	Description
SATZANW.15	1	MDI selection.
	0	Traversing block selection.

Selecting a traversing block number

When telegram 111 is used, set traversing block numbers bit 0 to bit 3 respectively with the PROFINET control words POS_STW1.0 to POS_STW1.3.

When telegrams 7, 9, and 110 are used, set traversing block numbers bit 0 to bit 3 respectively with the PROFINET control words SATZANW.0 to SATZANW.3.

Select one of the 16 traversing block numbers with the co-settings of bit 0 to bit 3:

Traversing block number	Bit 3	Bit 2	Bit 1	Bit 0
Traversing block 1	0	0	0	0
Traversing block 2	0	0	0	1
Traversing block 3	0	0	1	0
...	...			
Traversing block 16	1	1	1	1

Activating a traversing task

When telegrams 7, 9, 110, and 111 are used, activate a traversing task with the PROFINET control word STW1.6:

Control word	Setting	Description
STW1.6	1	Traversing task activation.
	0	Traversing task deactivation.

Parameter sets

Traversing blocks are parameterized using parameter sets that have a fixed structure:

- Task (p2621[0...15])
 - 1: POSITIONING
 - 2: FIXED ENDSTOP
 - 3: ENDLESS_POS
 - 4: ENDLESS_NEG
 - 5: WAIT
 - 6: GOTO
 - 7: SET_O
 - 8: RESET_O
 - 9: JERK
- Motion parameters
 - Target position or traversing distance (p2617[0...15])
 - Velocity (p2618[0...15])

- Acceleration override (p2619[0...15])
- Deceleration override (p2620[0...15])
- Task mode (p2623[0...15])

The execution of a traversing task can be influenced by parameter p2623 (task mode). This is automatically written by programming the traversing blocks in the engineering tool SINAMICS V-ASSISTANT.

Value = 0000 cccc bbbb aaaa

 - aaaa: Identifiers

000x → hide/show block (x = 0: show, x = 1: hide)
 - bbbb: Continuation condition

0000, END: 0/1 edge at STW1.6
 0001, CONTINUE_WITH_STOP:
 The exact position parameterized in the block is approached (brake to standstill and positioning window monitoring) before block processing can continue.
 0010, CONTINUE_ON-THE-FLY:
 The system switches to the next traversing block "on the fly" when the braking point for the current block is reached (if the direction needs to be changed, this does not occur until the drive stops within the positioning window).
 0011, CONTINUE_EXTERNAL:
 Same as "CONTINUE_ON-THE-FLY", except that an instant block change can be triggered up to the braking point by a 0/1 edge. If an external block change is not triggered, a block change is triggered at the braking point.
 0100, CONTINUE_EXTERNAL_WAIT:
 Control signal "External block change" can be used to trigger a flying changeover to the next task at any time during the traveling phase. If "External block change" is not triggered, the axis remains in the parameterized target position until the signal is issued. The difference here is that with CONTINUE_EXTERNAL, a flying changeover is carried out at the braking point if "External block change" has not been triggered, while here the drive waits for the signal in the target position.
 0101, CONTINUE_EXTERNAL_ALARM:
 This is the same as CONTINUE_EXTERNAL_WAIT, except that alarm A07463 "External traversing block change in traversing block x not requested" is output when "External block change" is not triggered by the time the drive comes to a standstill. The alarm can be converted to a fault with a stop response so that block processing can be canceled if the control signal is not issued.
 - cccc: positioning mode

The POSITIONING task (p2621 = 1) defines how the position specified in the traversing task is to be approached.

0000, ABSOLUTE:
 The position specified in p2617 is approached.
 0001, RELATIVE:
 The axis is traveled along the value specified in p2617
 0010, ABS_POS:
 For rotary axes with modulo offset only. The position specified in p2617 is approached in a positive direction.
 0011, ABS_NEG:
 For rotary axes with modulo offset only. The position specified in p2617 is approached in a negative direction.
- Task parameter (command-dependent significance) (p2622[0...15])

Traversing block tasks

POSITIONING

The POSITIONING task initiates motion. The following parameters are evaluated:

- p2616[x] Block number
- p2617[x] Position
- p2618[x] Velocity
- p2619[x] Acceleration override
- p2620[x] Deceleration override
- p2623[x] Task mode

The task is executed until the target position is reached. If, when the task is activated, the drive is already located at the target position, then for the block change enable (CONTINUE_ON-THE-FLY or CONTINUE_EXTERNAL), the next task is selected in the same interpolation cycle. For CONTINUE_WITH_STOP, the next block is activated in the next interpolation cycle. CONTINUE_EXTERNAL_ALARM causes a message to be output immediately.

FIXED STOP

The FIXED STOP task triggers a traversing movement with reduced torque to fixed stop.

The following parameters are relevant:

- p2616[x] Block number
- p2617[x] Position
- p2618[x] Velocity
- p2619[x] Acceleration override
- p2620[x] Deceleration override
- p2623[x] Task mode
- p2622[x] Task parameter clamping torque [0.01 Nm] with rotary motors.

Possible continuation conditions include END, CONTINUE_WITH_STOP, CONTINUE_EXTERNAL, CONTINUE_EXTERNAL_WAIT.

ENDLESS POS, ENDLESS NEG

Using these tasks, the axis is accelerated to the specified velocity and is moved until:

- A software limit switch is reached.
- A STOP cam signal has been issued.
- The traversing range limit is reached.
- Motion is interrupted by the control signal "no intermediate stop / intermediate stop" (STW1.5).
- Motion is interrupted by the control signal "do not reject traversing task / reject traversing task" (STW1.4).
- An external block change is triggered (with the appropriate continuation condition).

The following parameters are relevant:

- p2618[x] Velocity
- p2619[x] Acceleration override
- p2623[x] Task mode

All continuation conditions are possible.

JERK

Jerk limitation can be activated (command parameter = 1) or deactivated (task parameter = 0) by means of the JERK task. p2575 "Active jerk limitation" must be set to zero. The value parameterized in "jerk limit" p2574 is the jerk limit.

A precise stop is always carried out here regardless of the parameterized continuation condition of the task preceding the JERK task.

The following parameters are relevant:

- p2622[x] Task parameter = 0 or 1

All continuation conditions are possible.

WAIT

The WAIT task can be used to set a waiting period which should expire before the following task is processed.

The following parameters are relevant:

- p2622[x] Task parameter = delay time in milliseconds ≥ 0 ms, but is rounded-off to a multiple of numeral 8
- p2623[x] Task mode

Regardless of the parameterized continuation condition which is parameterized for the task that precedes the WAIT task, an exact stop is always executed before the waiting time expires. The WAIT task can be executed by an external block change.

Possible continuation conditions include END, CONTINUE_WITH_STOP, CONTINUE_EXTERNAL, CONTINUE_EXTERNAL_WAIT, and CONTINUE_EXTERNAL_ALARM. The fault message is triggered when "External block change" has still not been issued after the waiting time has elapsed.

GOTO

Using the GOTO task, jumps can be executed within a sequence of traversing tasks. The block number which is to be jumped to must be specified as task parameter. A continuation condition is not permissible. If there is no block with this number, then alarm A07468 (jump destination does not exist in traversing block x) is output and the block is designated as being inconsistent.

The following parameters are relevant:

- p2622[x] Task parameter = Next traversing block number

Any two of the SET_O, RESET_O and GOTO tasks can be processed in an interpolation cycle and a subsequent POSITION and WAIT task can be started.

SET_O, RESET_O

The tasks SET_O and RESET_O allow up to two binary signals (output 1 or 2) to be simultaneously set or reset. The number of the output (1 or 2) is specified bit-coded in the task parameter.

The following parameters are relevant:

- p2616[x] Block number
- p2622[x] Task parameter = bit-coded output:
 - 0x1: Output 1
 - 0x2: Output 2
 - 0x3: Output 1 and output 2

Possible continuation conditions are END, CONTINUE_ON-THE-FLY and CONTINUE_WITH_STOP, and CONTINUE_EXTERNAL_WAIT.

Any two of the SET_O, RESET_O and GOTO tasks can be processed in an interpolation cycle and a subsequent POSITIONING and WAIT task can be started.

Intermediate stop and reject a traversing task

When telegrams 7, 9, 110, and 111 are used, reject a traversing task with the PROFINET control word STW1.4:

Control word	Setting	Description
STW1.4	1	Do not reject a traversing task.
	0	Reject a traversing task (ramp-down with the maximum deceleration).

When telegrams 7, 9, 110, and 111 are used, perform an intermediate stop with the PROFINET control word STW1.5:

Control word	Setting	Description
STW1.5	1	No intermediate stop.
	0	Intermediate stop.

Overview of important parameters

- p2617[0...15] EPOS traversing block, position
- p2618[0...15] EPOS traversing block, velocity
- p2619[0...15] EPOS traversing block, acceleration override
- p2620[0...15] EPOS traversing block, deceleration override
- p2621[0...15] EPOS traversing block, task
- p2622[0...15] EPOS traversing block, task parameter
- p2623[0...15] EPOS traversing block, task mode

For more information about the parameters above, see Section "Parameter list (Page 247)".

7.2.10 Direct setpoint input (MDI)

The "direct setpoint input" function allows for positioning (absolute, relative) and setup (endless position-controlled) by means of direct setpoint inputs (e.g. via the PLC using process data).

During traversing, the motion parameters can also be influenced (on-the-fly setpoint acceptance) and an on-the-fly change can be undertaken between the "setting-up" and "positioning" modes. The "direct setpoint specification" mode (MDI) can also be used if the axis is not referenced in the "setting-up" or "relative positioning" modes.

Activating the direct setpoint input function

When telegram 111 is used, the direct setpoint input function can be configured with the PROFINET control word POS_STW1.15:

Control word	Setting	Description
POS_STW1.15	1	MDI selection.
	0	Traversing block selection.

When telegrams 7, 9, and 110 are used, the direct setpoint input function can be configured with the PROFINET control word SATZANW.15:

Control word	Setting	Description
SATZANW.15	1	MDI selection.
	0	Traversing block selection.

Selecting a working mode

In "positioning" mode, the parameters (position, velocity, acceleration and deceleration) can be used to carry out absolute or relative positioning.

In the "setting-up" mode, using parameters (velocity, acceleration and deceleration) endless closed-loop position control behavior can be carried out.

When telegram 111 is used, select a working mode with the PROFINET control word POS_STW1.14:

Control word	Setting	Description
POS_STW1.14	1	Signal setting-up selected.
	0	Signal positioning selected. ¹⁾

¹⁾ Telegrams 7, 9, and 110 can only work in signal positioning mode.

Features

Selecting a positioning type in signal positioning mode

When telegram 111 is used, select a positioning type with the PROFINET control word POS_STW1.8:

Control word	Setting	Description
POS_STW1.8	1	Absolute positioning is selected.
	0	Relative positioning is selected.

When telegram 9 is used, select a positioning type with the PROFINET control word MDI_MOD.0:

Control word	Setting	Description
MDI_MOD.0	1	Absolute positioning is selected.
	0	Relative positioning is selected.

When telegram 7 is used, select a positioning type with the following parameter:

Parameter	Setting	Description
p29231	0 (default)	Relative positioning is selected.
	1	Absolute positioning is selected.

Selecting an absolute positioning direction in signal positioning mode

When telegram 111 is used, select an absolute positioning direction with the PROFINET control words POS_STW1.9 and POS_STW1.10:

Control word	Setting	Description
POS_STW1.9	0	Absolute positioning through the shortest distance.
POS_STW1.10	1	Absolute positioning/MDI direction selection, positive.
	2	Absolute positioning/MDI direction selection, negative.
	3	Absolute positioning through the shortest distance.

When telegram 9 is used, select an absolute positioning direction with the PROFINET control words MDI_MOD.1 and MDI_MOD.2:

Control word	Setting	Description
MDI_MOD.1	0	Absolute positioning through the shortest distance.
MDI_MOD.2	1	Absolute positioning/MDI direction selection, positive.
	2	Absolute positioning/MDI direction selection, negative.
	3	Absolute positioning through the shortest distance.

When telegram 7 is used, select an absolute positioning direction with the following parameter:

Parameter	Setting	Description
p29230	0 (default)	Absolute positioning through the shortest distance.
	1	Absolute positioning/MDI direction selection, positive.
	2	Absolute positioning/MDI direction selection, negative.

Selecting a direction in signal setting-up mode

Control word	Setting	Description
POS_STW1.9	1	MDI direction selection, positive.
POS_STW1.10	2	MDI direction selection, negative.

MDI mode with the use of telegram 110

When telegram 110 is used, select a positioning type and an absolute positioning direction with the PROFINET control word MDI_MODE (PZD12):

- xx0x = absolute
- xx1x = relative
- xx2x = ABS_POS
- xx3x = ABS_NEG

Selecting an MDI transfer type

When telegram 111 is used, select an MDI transfer type with the PROFINET control word POS_STW1.12:

Control word	Setting	Description
POS_STW1.12	1	Continuous transfer.
	0	Activate MDI block change with of a traversing task (STW1.6).

Note

When telegrams 7, 9, and 110 are used, a rising edge is fixed.

Setting MDI setpoints

When telegrams 9, 110, and 111 are used, set MDI setpoints with the following PROFINET control words:

- Position setpoint (MDI_TARPOS): 1 hex = 1 LU
- Velocity setpoint (MDI_VELOCITY): 1 hex = 1000 LU/min
- Acceleration override (MDI_ACC): 4000 hex = 100%
- Deceleration override (MDI_DEC): 4000 hex = 100%

When telegram 7 is used, set MDI setpoints with the following parameters:

- Position setpoint (p2690)
- Velocity setpoint (p2691)
- Acceleration override (p2692)
- Deceleration override (p2693)

Intermediate stop and reject an MDI task

When telegrams 7, 9, 110, and 111 are used, reject an MDI task with the PROFINET control word STW1.4:

Control word	Setting	Description
STW1.4	1	Do not reject a traversing task.
	0	Reject a traversing task (ramp-down with the maximum deceleration).

When telegrams 7, 9, 110, and 111 are used, perform an intermediate stop with the PROFINET control word STW1.5:

Control word	Setting	Description
STW1.5	1	No intermediate stop.
	0	Intermediate stop with parameterized deceleration MDI_DEC (telegrams 9, 110, and 111) or p2693 (telegram 7).

Overview of important parameters

- p2690 MDI position, fixed setpoint
- p2691 MDI velocity, fixed setpoint
- p2692 MDI acceleration override, fixed setpoint
- p2693 MDI deceleration override, fixed setpoint

For more information about the parameters above, see Section "Parameter list (Page 247)".

7.2.11 EJOG

When telegrams 7, 9, 110, and 111 are used, select a jogging channel with the PROFINET control words STW1.8 and STW1.9:

Control word	Setting	Description
STW1.8	0	No jogging channel activated.
STW1.9	1	Jog 1 signal source rising edge activated.
	2	Jog 2 signal source rising edge activated.
	3	Reserved.

Features

Selecting a jogging mode

When telegram 110 is used, select a jogging mode with the PROFINET control word POS_STW.5:

Control word	Setting	Description
POS_STW.5	1	Jogging, incremental active.
	0	Jogging, velocity active.

When telegram 111 is used, select a jogging mode with the PROFINET control word POS_STW2.5:

Control word	Setting	Description
POS_STW2.5	1	Jogging, incremental active.
	0	Jogging, velocity active.

Note

When telegrams 7 and 9 are used, endless jogging is fixed.

Setting jogging setpoints

When telegrams 7 and 9 are used, set the following jogging setpoint with the appropriate parameters:

- Velocity (p2585, p2586)

When telegrams 110 and 111 are used, set the following jogging setpoints with the appropriate parameters:

- Velocity (p2585, p2586)
- Incremental (p2587, p2588)

Overview of important parameters

- p2585 EPOS jog 1 setpoint velocity
- p2586 EPOS jog 2 setpoint velocity
- p2587 EPOS jog 1 travel distance
- p2588 EPOS jog 2 travel distance

For more information about the parameters above, see Section "Parameter list (Page 247)".

7.3 Speed control (S)

7.3.1 Speed limit

Two sources in total are available for the speed limit. You can select one of them via a combination of digital input signal SLIM:

Digital signal (SLIM)	Speed limit
0	Internal speed limit 1
1	Internal speed limit 2

Note

The bit 0 of parameter p29108 **must** be set to 1 to enable the speed limit function.

Note

You can switch between the two sources and modify their values when the servo drive is running.

Note

Fault F7901 occurs when the actual speed exceeds the positive speed limit + hysteresis speed (p2162) or the negative speed limit - hysteresis speed (p2162). Go to "List of faults and alarms (Page 287)" for information about the acknowledgment of this fault.

Refer to "DIs (Page 103)" for more information about the digital input signal SLIM.

Overall speed limit

Besides the above two channels, an overall speed limit is also available.

You can configure the overall speed limit by setting the following parameters:

Parameter	Value range	Default	Unit	Description
p1083	0 to 210000	210000	rpm	Overall speed limit (positive)
p1086	-210000 to 0	-210000	rpm	Overall speed limit (negative)

Internal speed limit

Select an internal speed limit by setting the following parameters:

Parameter	Value range	Default	Unit	Description	Digital input (SLIM)
p29070[0]	0 to 210000	210000	rpm	Internal speed limit 1 (positive)	0
p29070[1]	0 to 210000	210000	rpm	Internal speed limit 2 (positive)	1
p29071[0]	-210000 to 0	-210000	rpm	Internal speed limit 1 (negative)	0
p29071[1]	-210000 to 0	-210000	rpm	Internal speed limit 2 (negative)	1

Note

After the motor is commissioned, p1082, p1083, p1086, p29070 and p29071 are set to the maximum speed of the motor automatically.

7.3.2 Torque limit

Two sources in total are available for the torque limit. You can select one of them via the digital input signal TLIM:

Digital input (TLIM)	Torque limit
0	Internal torque limit 1
1	Internal torque limit 2

When the torque setpoint reaches torque limit, the torque is limited to the value selected by TLIM.

Note

You can switch between the two sources and modify their values when the servo drive is running.

Refer to "DIs (Page 103)" for more information about the digital input signal TLIM.

Overall torque limit

Besides the above two sources, an overall torque limit is also available. The overall torque limit takes effect when an emergency stop (OFF3) happens. In this case, the servo drive brakes with a maximum torque.

You can configure the overall torque limit by setting the following parameters:

Parameter	Value range	Default	Unit	Description
p1520	-1000000.00 to 2000000.00	0	Nm	Overall torque limit (positive)
p1521	-2000000.00 to 1000000.00	0	Nm	Overall torque limit (negative)

Internal torque limit

Select an internal torque limit by setting the following parameters:

Parameter	Value range	Default	Unit	Description	Digital input (TLIM)
p29050[0]	-150 to 300	300	%	Internal torque limit 1 (positive)	0
p29050[1]	-150 to 300	300	%	Internal torque limit 2 (positive)	1
p29051[0]	-300 to 150	-300	%	Internal torque limit 1 (negative)	0
p29051[1]	-300 to 150	-300	%	Internal torque limit 2 (negative)	1

The following diagram shows how the internal torque limit functions:

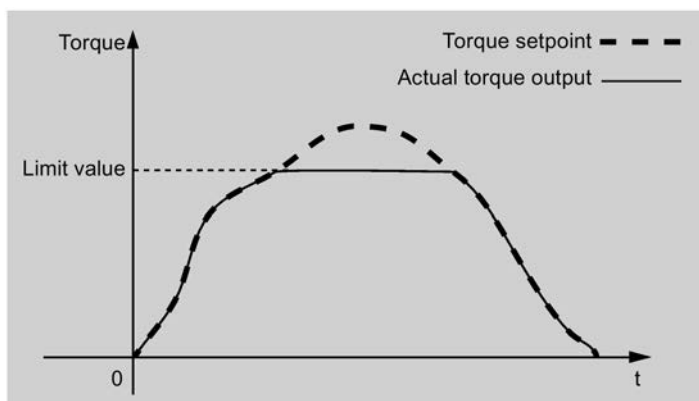

Torque limit reached (TLR)

When the generated torque has nearly (internal hysteresis) reached the value of the positive torque limit or negative torque limit, the signal TLR is output.

7.3.3 Ramp-function generator

The ramp-function generator is used to limit acceleration in the event of abrupt setpoint changes and thus helps prevent load surges during drive operation.

The ramp-up time p1120 and ramp-down time p1121 can be used to set acceleration and deceleration ramps separately. This allows a smoothed transition in the event of setpoint changes.

The maximum speed p1082 is used as the reference value for calculating the ramp-up and ramp-down times.

You can see the properties of the ramp-function generator from the diagram below:

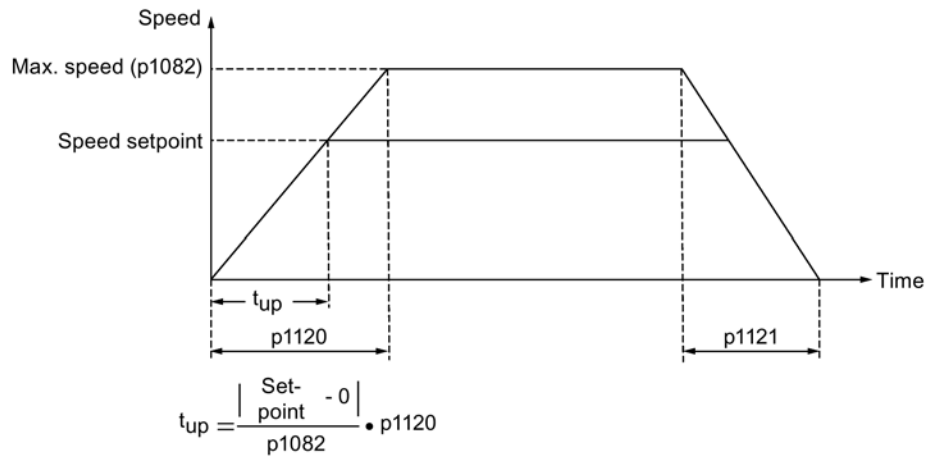

S-curve ramp-function generator

You can also use the S-curve ramp-function generator by setting p1115 to 1. The S-curve ramp-function generator is realized with the following parameters:

- the acceleration (p1120) and deceleration (p1121) ramps
- the initial (p1130) and final (p1131) rounding-off times

You can see the properties of the S-curve ramp-function generator from the diagram below:

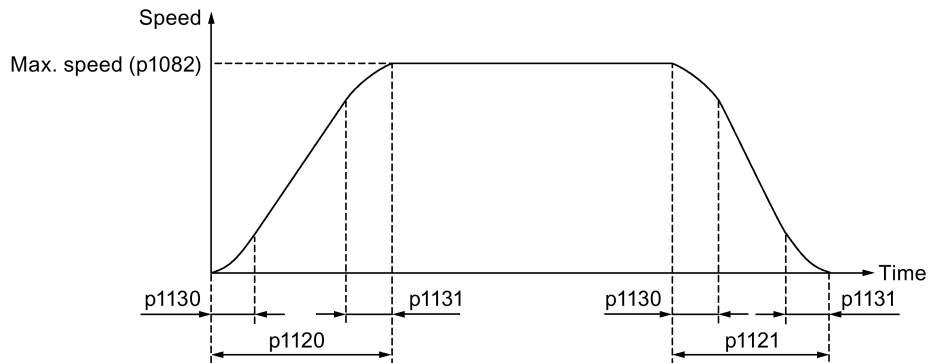

Parameter settings

Parameter	Range	Default	Unit	Description
p1082	0 to 210000	1500	rpm	Maximum motor speed
p1115	0 to 1	0	-	Ramp-function generator selection
p1120	0 to 999999	1	s	Ramp-function generator ramp-up time
p1121	0 to 999999	1	s	Ramp-function generator ramp-down time
p1130	0 to 30	0	s	Ramp-function generator initial rounding-off time
p1131	0 to 30	0	s	Ramp-function generator final rounding-off time

PROFINET communication

PROFINET IO is a real time protocol based on Ethernet. It is used as high level network for industrial automation applications. PROFINET IO focuses on the data exchange for a programmable controller. A PROFINET IO network consists of the following devices:

- IO controller: typically, it is the PLC, which controls the whole application
- IO device: a decentralized IO device (for example, encoder, sensor), which is controlled by the IO controller
- IO supervisor: HMI (human machine interface) or PC for diagnostic purposes or commissioning

PROFINET supplies two kinds of real time communication, that is, PROFINET IO RT (Real Time) and PROFINET IO IRT (Isochronous Real Time). The real time channel is used for IO data and alarm mechanism.

In PROFINET IO RT, the RT data is transferred via a prioritized Ethernet frame. No special hardware is required. Due to this prioritization a cycle time of 4 ms can be achieved. PROFINET IO IRT is used for more precise timing requirements. Cycle time of 2 ms is possible, but also special hardware for IO devices and switches are required.

All diagnostic and configuration data is transferred via the non-real time channel (NRT). For this purpose the common TCP/IP protocol is used. Anyhow, no timing can be guaranteed and typically the cycle times can be more than 100 ms.

8.1 Supported telegrams

SINAMICS V90 PN supports standard telegrams and Siemens telegrams for speed control mode and basic positioner control mode. You can select the desired telegram with parameter p0922. See the following table for details.

From the perspective of the drive unit, the received process data represents the receive words and the process data to be sent represents the send words.

Telegram	Maximum number of PZD		Description
	Receive word	Send word	
Standard telegram 1	2	2	p0922 = 1
Standard telegram 2	4	4	p0922 = 2
Standard telegram 3	5	9	p0922 = 3
Standard telegram 5	9	9	p0922 = 5
Standard telegram 7	2	2	p0922 = 7
Standard telegram 9	10	5	p0922 = 9
Siemens telegram 102	6	10	p0922 = 102
Siemens telegram 105	10	10	p0922 = 105

8.1 Supported telegrams

Telegram	Maximum number of PZD		Description
	Receive word	Send word	
Siemens telegram 110	12	7	p0922 = 110
Siemens telegram 111	12	12	p0922 = 111



One PZD = one word

Standard telegram 5 and Siemens telegram 105 can only be used when the V90 PN connects to the SIMATICS S7-1500 and the TIA Portal version is V14 or higher.

Telegrams used for speed control mode

Tele-gram	1		2		3		5		102		105		
Appl. class	1		1		1, 4		4		1, 4		4		
PZD1	STW1	ZSW1	STW1	ZSW1	STW1	ZSW1	STW1	ZSW1	STW1	ZSW1	STW1	ZSW1	
PZD2	NSOLL_A	NIST_A	NSOLL_B	NIST_B	NSOLL_B	NIST_B	NSOLL_B	NIST_B	NSOLL_B	NIST_B	NSOLL_B	NIST_B	
PZD3	↑ Receive telegram from PROFINET	↓ Send telegram to PROFINET											
PZD4			STW2	ZSW2	STW2	ZSW2	STW2	ZSW2	STW2	ZSW2	STW2	ZSW2	ZSW2
PZD5					G1_STW	G1_ZSW	G1_STW	G1_ZSW	MOMRED	MELDW	MOMRED	MELDW	MELDW
PZD6						G1_XIS T1	XERR	G1_XIS T1	G1_STW	G1_ZSW	G1_STW	G1_ZSW	G1_ZSW
PZD7										G1_XIS T1	XERR	G1_XIS T1	G1_XIS T1
PZD8						G1_XIS T2	KPC	G1_XIS T2		G1_XIS T2	KPC	G1_XIS T2	G1_XIS T2
PZD9										G1_XIS T2	KPC	G1_XIS T2	G1_XIS T2
PZD10													

Telegrams used for basic positioner control mode

Telegram	7		9		110		111			
Appl. class	3		3		3		3			
PZD1	STW1	ZSW1	STW1	ZSW1	STW1	ZSW1	STW1	ZSW1		
PZD2	SATZANW	AKTSATZ	SATZANW	AKTSATZ	SATZANW	AKTSATZ	POS_STW 1	POS_ZSW 1		
PZD3	 Receive telegram from PROFINET	 Send telegram to PROFINET	STW2	ZSW2	POS_STW	POS_ZSW	POS_STW 2	POS_ZSW 2		
PZD4			MDI_TARPOS	XIST_A	STW2	ZSW2	STW2	ZSW2	STW2	ZSW2
PZD5					OVERVERRIDE	MELDW	OVERVERRIDE	MELDW	OVERVERRIDE	MELDW
PZD6			MDI_VELOCITY		MDI_TAR POS	XIST_A	MDI_TAR POS	XIST_A	MDI_TAR POS	XIST_A
PZD7										
PZD8			MDI_ACC		MDI_VELO CITY		MDI_VELO CITY		MDI_VELO CITY	NIST_B
PZD9			MDI_DEC							
PZD10			MDI_MOD		MDI_ACC		MDI_ACC		MDI_ACC	FAULT_CO DE
PZD11							MDI_DEC		MDI_DEC	WARN_CO DE
PZD12							MDI_MODE		user ¹⁾	user ²⁾

1) User-defined receive word

2) User-defined send word

Note

When you use the telegram 110 and 111 in EPOS functions JOG, MDI, traversing block, and referencing, the value of the PZD5 OVERRIDE affects the speed.

8.2 I/O data signals

Parameters p200x apply as reference variables (telegram contents = 4000 hex or 40000000 hex in the case of double words if the input variable has the value p200x).

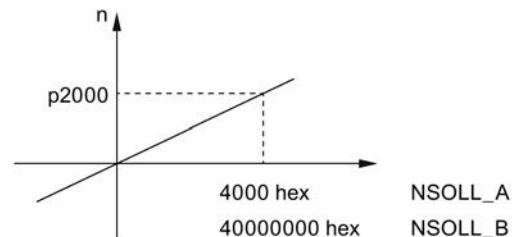

The following table provides an overview of the I/O data used in the telegram.

Signal	Description	Receive word/send word	Data type	Scaling
STW1	Control word 1	Receive word	U16	-
STW2	Control word 2	Receive word	U16	-
ZSW1	Status word 1	Send word	U16	-
ZSW2	Status word 2	Send word	U16	-
NSOLL_A	Speed setpoint A (16 bit)	Receive word	I16	4000 hex \triangleq p2000
NSOLL_B	Speed setpoint B (32 bit)	Receive word	I32	40000000 hex \triangleq p2000
NIST_A	Speed actual value A (16 bit)	Send word	I16	4000 hex \triangleq p2000
NIST_B	Speed actual value B (32 bit)	Send word	I32	40000000 hex \triangleq p2000
G1_STW	Encoder 1 control word	Receive word	U16	-
G1_ZSW	Encoder 1 status word	Send word	U16	-
G1_XIST1	Encoder 1 actual position 1	Send word	U32	-
G1_XIST2	Encoder 1 actual position 2	Send word	U32	-
MOMRED	Torque reduction	Receive word	I16	4000 hex \triangleq p2003
MELDW	Message word	Send word	U16	-
KPC	Position controller gain factor	Receive word	I32	-
XERR	Position deviation	Receive word	I32	-
SATZANW	Position block selection	Receive word	U16	-
AKTSATZ	Selected position block	Send word	U16	-
MDI_TAR POS	MDI position	Receive word	I32	1 hex \triangleq 1 LU
MDI_VELO CITY	MDI velocity	Receive word	I32	1 hex \triangleq 1000 LU/min
MDI_ACC	MDI acceleration override	Receive word	I16	4000 hex \triangleq 100%
MDI_DEC	MDI deceleration override	Receive word	I16	4000 hex \triangleq 100%
XIST_A	Position actual value A	Send word	I32	1 hex \triangleq 1 LU
OVERRIDE 1)	Position velocity override	Receive word	I16	4000 hex \triangleq 100%
MDI_MODE	Position MDI mode	Receive word	U16	-
FAULT_CO DE	Fault code	Send word	U16	-
WARN_CO DE	Alarm code	Send word	U16	-
POS_ZSW	Position status word	Send word	U16	-

Signal	Description	Receive word/send word	Data type	Scaling
user ²⁾	User-defined receive word (depends on the value of p29150): <ul style="list-style-type: none"> • p29150 = 0: No function • p29150 = 1: Torque feedforward • p29150 = 2: Speed feedforward 	Receive word	l16	<ul style="list-style-type: none"> • Torque feedforward (4000 hex \triangleq p2003) • Speed feedforward (4000 hex \triangleq p2003)
user	User-defined send word (depends on the value of p29151): <ul style="list-style-type: none"> • p29151 = 0: No function • p29151 = 1: Actual torque • p29151 = 2: Actual absolute current • p29151 = 3: DI status 	Send word	l16	<ul style="list-style-type: none"> • Actual torque (4000 hex \triangleq p2003) • Actual absolute current (4000 hex \triangleq p2003)

1) Make sure that signal OVERRIDE is set to a value from 0 to 32767.

2) When you use the auto-tuning function, values of the torque feedforward and speed feedforward can be overwritten after the tuning function is enabled. If you want to use functions of the torque feedforward and speed feedforward, you need to set their values to the required values again.

8.3 Control word definition

8.3.1 STW1 control word (for telegrams 1, 2, 3, 5)

Note



When p29108.0 = 0, STW1.11 is disabled.

Note

When telegram 5 is used, STW1.4, STW1.5, and STW1.6 are disabled.

Note

STW1.10 must be set to 1 to allow the PLC to control the drive.

Signal	Description
STW1.0	 = ON (pulses can be enabled) 0 = OFF1 (braking with ramp-function generator, then pulse suppression and ready for switching on)
STW1.1	1 = No OFF2 (enable is possible) 0 = OFF2 (immediate pulse suppression and switching on inhibited)
STW1.2	1 = No OFF3 (enable is possible) 0 = OFF3 (braking with the OFF3 ramp p1135, then pulse suppression and switching on inhibited)
STW1.3	1 = Enable operation (pulses can be enabled) 0 = Inhibit operation (suppress pulses)
STW1.4	1 = Operating condition (the ramp-function generator can be enabled) 0 = Inhibit ramp-function generator (set the ramp-function generator output to zero)
STW1.5	1 = Continue ramp-function generator 0 = Freeze ramp-function generator (freeze the ramp-function generator output)
STW1.6	1 = Enable setpoint 0 = Inhibit setpoint (set the ramp-function generator input to zero)
STW1.7	 = 1. Acknowledge faults
STW1.8	Reserved
STW1.9	Reserved
STW1.10	1 = Control via PLC
STW1.11	1 = Setpoint inversion
STW1.12	Reserved
STW1.13	Reserved
STW1.14	Reserved
STW1.15	Reserved

8.3.2 STW2 control word (for telegrams 2, 3, 5)

Signal	Description
STW2.0	Reserved
STW2.1	Reserved
STW2.2	Reserved
STW2.3	Reserved
STW2.4	Reserved
STW2.5	Reserved
STW2.6	Reserved
STW2.7	Reserved
STW2.8	1 = Traverse to fixed endstop
STW2.9	Reserved
STW2.10	Reserved

Signal	Description
STW2.11	Reserved
STW2.12	Master sign-of-life, bit 0
STW2.13	Master sign-of-life, bit 1
STW2.14	Master sign-of-life, bit 2
STW2.15	Master sign-of-life, bit 3



8.3.3 STW1 control word (for telegrams 102, 105)

Note

When telegram 105 is used, STW1.4, STW1.5, and STW1.6 are disabled.

Note

STW1.10 must be set to 1 to allow PLC to control the drive.

Signal	Description
STW1.0	 = ON (pulses can be enabled) 0 = OFF1 (braking with ramp-function generator, then pulse suppression and ready for switching on)
STW1.1	1 = No OFF2 (enable is possible) 0 = OFF2 (immediate pulse suppression and switching on inhibited)
STW1.2	1 = No OFF3 (enable is possible) 0 = OFF3 (braking with the OFF3 ramp p1135, then pulse suppression and switching on inhibited)
STW1.3	1 = Enable operation (pulses can be enabled) 0 = Inhibit operation (suppress pulses)
STW1.4	1 = Operating condition (the ramp-function generator can be enabled) 0 = Inhibit ramp-function generator (set the ramp-function generator output to zero)
STW1.5	1 = Continue ramp-function generator 0 = Freeze ramp-function generator (freeze the ramp-function generator output)
STW1.6	1 = Enable setpoint 0 = Inhibit setpoint (set the ramp-function generator input to zero)
STW1.7	 = 1. Acknowledge faults
STW1.8	Reserved
STW1.9	Reserved
STW1.10	1 = Control via PLC
STW1.11	1 = Ramp-function generator active
STW1.12	1 = Unconditionally open the holding brake
STW1.13	Reserved
STW1.14	Reserved
STW1.15	Reserved

8.3.4 STW2 control word (for telegrams 102, 105)

Note

When p29108.0 = 0, STW2.4 is disabled.

Signal	Description
STW2.0	Reserved
STW2.1	Reserved
STW2.2	Reserved
STW2.3	Reserved
STW2.4	1 = Bypass ramp-function generator
STW2.5	Reserved
STW2.6	1 = Integrator inhibit, speed controller
STW2.7	Reserved
STW2.8	1 = Traverse to fixed endstop
STW2.9	Reserved
STW2.10	Reserved
STW2.11	Reserved
STW2.12	Master sign-of-life, bit 0
STW2.13	Master sign-of-life, bit 1
STW2.14	Master sign-of-life, bit 2
STW2.15	Master sign-of-life, bit 3

8.3.5 STW1 control word (for telegrams 7, 9, 110, 111)

Note

STW1.10 must be set to 1 to allow the PLC to control the drive.

Signal	Description
STW1.0	 = ON (pulses can be enabled) 0 = OFF1 (braking with ramp-function generator, then pulse suppression and ready for switching on)
STW1.1	1 = No OFF2 (enable is possible) 0 = OFF2 (immediate pulse suppression and switching on inhibited)
STW1.2	1 = No OFF3 (enable is possible) 0 = OFF3 (braking with the OFF3 ramp p1135, then pulse suppression and switching on inhibited)
STW1.3	1 = Enable operation (pulses can be enabled) 0 = Inhibit operation (suppress pulses)
STW1.4	1 = Do not reject traversing task 0 = Reject traversing task (ramp-down with the maximum deceleration)

STW1.5	1 = No intermediate stop 0 = Intermediate stop
STW1.6	⏮ = Activate traversing task
STW1.7	⏮ = Acknowledge faults
STW1.8	1 = Jog 1 signal source
STW1.9	1 = Jog 2 signal source
STW1.10	1 = Control via PLC
STW1.11	1 = Start referencing 0 = Stop referencing
STW1.12	Reserved
STW1.13	⏮ = External block change
STW1.14	Reserved
STW1.15	Reserved

8.3.6 STW2 control word (for telegrams 9, 110, 111)

Signal	Description
STW2.0	Reserved
STW2.1	Reserved
STW2.2	Reserved
STW2.3	Reserved
STW2.4	Reserved
STW2.5	Reserved
STW2.6	Reserved
STW2.7	Reserved
STW2.8	1 = Traverse to fixed endstop
STW2.9	Reserved
STW2.10	Reserved
STW2.11	Reserved
STW2.12	Master sign-of-life, bit 0
STW2.13	Master sign-of-life, bit 1
STW2.14	Master sign-of-life, bit 2
STW2.15	Master sign-of-life, bit 3

8.3.7 G1_STW encoder 1 control word

Signal	Description																
G1_STW.0	Selects the function to be activate (with bit value = 1)																
G1_STW.1																	
G1_STW.2																	
G1_STW.3		<table border="1"> <thead> <tr> <th>Function No.</th> <th>Function for bit 7 = 0 (search for reference mark)</th> <th>Function for bit 7 = 1 (flying measurement)</th> </tr> </thead> <tbody> <tr> <td>1</td> <td>Reference mark 1</td> <td>⏴ Measuring probe 1</td> </tr> <tr> <td>2</td> <td>Reference mark 2</td> <td>⏵ Measuring probe 1</td> </tr> <tr> <td>3</td> <td>Reference mark 3</td> <td>⏴ Measuring probe 2</td> </tr> <tr> <td>4</td> <td>Reference mark 4</td> <td>⏵ Measuring probe 2</td> </tr> </tbody> </table>	Function No.	Function for bit 7 = 0 (search for reference mark)	Function for bit 7 = 1 (flying measurement)	1	Reference mark 1	⏴ Measuring probe 1	2	Reference mark 2	⏵ Measuring probe 1	3	Reference mark 3	⏴ Measuring probe 2	4	Reference mark 4	⏵ Measuring probe 2
		Function No.	Function for bit 7 = 0 (search for reference mark)	Function for bit 7 = 1 (flying measurement)													
1	Reference mark 1	⏴ Measuring probe 1															
2	Reference mark 2	⏵ Measuring probe 1															
3	Reference mark 3	⏴ Measuring probe 2															
4	Reference mark 4	⏵ Measuring probe 2															
G1_STW.4	Start/stop/read selected function																
G1_STW.5																	
G1_STW.6		<table border="1"> <tbody> <tr> <td>0</td> <td>1</td> <td>0</td> <td>1</td> </tr> <tr> <td>0</td> <td>0</td> <td>1</td> <td>1</td> </tr> <tr> <td>0</td> <td>0</td> <td>0</td> <td>0</td> </tr> </tbody> </table> <p> ———— Interrupt function ———— Read generated value ———— Activate selected function ———— No function </p>	0	1	0	1	0	0	1	1	0	0	0	0			
0	1	0	1														
0	0	1	1														
0	0	0	0														
G1_STW.7	Mode of the function to be activated 1 = Flying measurement 0 = Search for reference mark																
G1_STW.8	Reserved																
G1_STW.9	Reserved																
G1_STW.10	Reserved																
G1_STW.11	Reserved																
G1_STW.12	Reserved																
G1_STW.13	1 = Request value cyclic transfer of the absolute position value in Gn_XIST2																
G1_STW.14	1 = Request parking encoder																
G1_STW.15	⏴ = Acknowledge encoder fault																

8.3.8 SATZANW control word

Signal	Description
SATZANW.0	1 = Traversing block selection, bit 0
SATZANW.1	1 = Traversing block selection, bit 1
SATZANW.2	1 = Traversing block selection, bit 2
SATZANW.3	1 = Traversing block selection, bit 3
SATZANW.4	1 = Traversing block selection, bit 4

Signal	Description
SATZANW.5	1 = Traversing block selection, bit 5
SATZANW.6	Reserved
SATZANW.7	Reserved
SATZANW.8	Reserved
SATZANW.9	Reserved
SATZANW.10	Reserved
SATZANW.11	Reserved
SATZANW.12	Reserved
SATZANW.13	Reserved
SATZANW.14	Reserved
SATZANW.15	1 = Activate MDI 0 = Deactivate MDI

8.3.9 MDI_MOD control word

Signal	Description
MDI_MOD.0	1 = Absolute positioning is selected 0 = Relative positioning is selected
MDI_MOD.1	0 = Absolute positioning through the shortest distance
MDI_MOD.2	1 = Absolute positioning in the positive direction 2 = Absolute positioning in the negative direction 3 = Absolute positioning through the shortest distance
MDI_MOD.3	Reserved
MDI_MOD.4	Reserved
MDI_MOD.5	Reserved
MDI_MOD.6	Reserved
MDI_MOD.7	Reserved
MDI_MOD.8	Reserved
MDI_MOD.9	Reserved
MDI_MOD.10	Reserved
MDI_MOD.11	Reserved
MDI_MOD.12	Reserved
MDI_MOD.13	Reserved
MDI_MOD.14	Reserved
MDI_MOD.15	Reserved

8.3.10 POS_STW control word

Signal	Description
POS_STW.0	1 = Tracking mode active 0 = No tracking mode active
POS_STW.1	1 = Set reference point 0 = Do not set reference point
POS_STW.2	1 = Reference cam active
POS_STW.3	Reserved
POS_STW.4	Reserved
POS_STW.5	1 = Jogging, incremental active 0 = Jogging, velocity active
POS_STW.6	Reserved
POS_STW.7	Reserved
POS_STW.8	Reserved
POS_STW.9	Reserved
POS_STW.10	Reserved
POS_STW.11	Reserved
POS_STW.12	Reserved
POS_STW.13	Reserved
POS_STW.14	Reserved
POS_STW.15	Reserved

Note

If the tracking mode is activated, the position setpoint follows the actual position value, i.e. position setpoint = actual position value.

8.3.11 POS_STW1 positioning control word

Signal	Description
POS_STW1.0	Traversing block selection, bit 0
POS_STW1.1	Traversing block selection, bit 1
POS_STW1.2	Traversing block selection, bit 2
POS_STW1.3	Traversing block selection, bit 3
POS_STW1.4	Traversing block selection, bit 4
POS_STW1.5	Traversing block selection, bit 5
POS_STW1.6	Reserved
POS_STW1.7	Reserved
POS_STW1.8	1 = Absolute positioning is selected 0 = Relative positioning is selected
POS_STW1.9	0 = Absolute positioning through the shortest distance

Signal	Description
POS_STW1.10	1 = Absolute positioning/MDI direction selection, positive 2 = Absolute positioning/MDI direction selection, negative 3 = Absolute positioning through the shortest distance
POS_STW1.11	Reserved
POS_STW1.12	1 = Continuous transfer 0 = Activate MDI block change with  of a traversing task (STW1.6)
POS_STW1.13	Reserved
POS_STW1.14	1 = Signal setting-up selected 0 = Signal positioning selected
POS_STW1.15	1 = MDI selection

8.3.12 POS_STW2 positioning control word

Signal	Description
POS_STW2.0	1 = Tracking mode active
POS_STW2.1	1 = Set reference point
POS_STW2.2	1 = Reference cam active
POS_STW2.3	Reserved
POS_STW2.4	Reserved
POS_STW2.5	1 = Jogging, incremental active 0 = Jogging, velocity active
POS_STW2.6	Reserved
POS_STW2.7	Reserved
POS_STW2.8	Reserved
POS_STW2.9	1 = Start the search for reference in the negative direction 0 = Start the search for reference in the positive direction
POS_STW2.10	Reserved
POS_STW2.11	Reserved
POS_STW2.12	Reserved
POS_STW2.13	Reserved
POS_STW2.14	1 = Software limit switch activation
POS_STW2.15	1 = STOP cam active

Note

If the tracking mode is activated, the position setpoint follows the actual position value, i.e. position setpoint = actual position value.

8.4 Status word definition

8.4.1 ZSW1 status word (for telegrams 1, 2, 3, 5)

Signal	Description
ZSW1.0	1 = Ready for servo on
ZSW1.1	1 = Ready for operation
ZSW1.2	1 = Operation enabled
ZSW1.3	1 = Fault present
ZSW1.4	1 = No coast down active (OFF2 inactive)
ZSW1.5	1 = No fast stop active (OFF3 inactive)
ZSW1.6	1 = Switching on inhibited active
ZSW1.7	1 = Alarm present
ZSW1.8	1 = Speed setpoint - actual value deviation within tolerance t_off
ZSW1.9	1 = Control requested
ZSW1.10	1 = f or n comparison value reached/exceeded
ZSW1.11	0 = I, M, or P limit reached
ZSW1.12	1 = Open the holding brake
ZSW1.13	1 = No motor overtemperature alarm
ZSW1.14	1 = Motor rotates forwards (n_act ≥ 0) 0 = Motor rotates backwards (n_act < 0)
ZSW1.15	1 = No alarm, thermal overload, power unit

8.4.2 ZSW2 status word (for telegrams 2, 3, 5)

Signal	Description
ZSW2.0	Reserved
ZSW2.1	Reserved
ZSW2.2	Reserved
ZSW2.3	Reserved
ZSW2.4	Reserved
ZSW2.5	1 = Alarm class bit 0
ZSW2.6	1 = Alarm class bit 1
ZSW2.7	Reserved
ZSW2.8	1 = Traverse to fixed endstop
ZSW2.9	Reserved
ZSW2.10	1 = Pulses enabled
ZSW2.11	Reserved
ZSW2.12	Slave sign-of-life, bit 0

Signal	Description
ZSW2.13	Slave sign-of-life, bit 1
ZSW2.14	Slave sign-of-life, bit 2
ZSW2.15	Slave sign-of-life, bit 3

8.4.3 ZSW1 status word (for telegrams 102, 105)

Signal	Description
ZSW1.0	1 = Ready for servo on
ZSW1.1	1 = Ready for operation
ZSW1.2	1 = Operation enabled
ZSW1.3	1 = Fault present
ZSW1.4	1 = No coast down active (OFF2 inactive)
ZSW1.5	1 = No fast stop active (OFF3 inactive)
ZSW1.6	1 = Switching on inhibited active
ZSW1.7	1 = Alarm present
ZSW1.8	1 = Speed setpoint - actual value deviation within tolerance t_off
ZSW1.9	1 = Control requested
ZSW1.10	1 = f or n comparison value reached/exceeded
ZSW1.11	1 = Alarm class bit 0
ZSW1.12	1 = Alarm class bit 1
ZSW1.13	Reserved
ZSW1.14	1 = Closed-loop torque control active
ZSW1.15	Reserved

8.4.4 ZSW2 status word (for telegrams 102, 105)

Signal	Description
ZSW2.0	Reserved
ZSW2.1	Reserved
ZSW2.2	Reserved
ZSW2.3	Reserved
ZSW2.4	1 = Ramp-function generator inactive
ZSW2.5	1 = Open the holding brake
ZSW2.6	1 = Integrator inhibit, speed controller
ZSW2.7	Reserved
ZSW2.8	1 = Traverse to fixed endstop
ZSW2.9	Reserved
ZSW2.10	Reserved

8.4 Status word definition

Signal	Description
ZSW2.11	Reserved
ZSW2.12	Slave sign-of-life, bit 0
ZSW2.13	Slave sign-of-life, bit 1
ZSW2.14	Slave sign-of-life, bit 2
ZSW2.15	Slave sign-of-life, bit 3

8.4.5 ZSW1 status word (for telegrams 7, 9, 110, 111)













Signal	Description
ZSW1.0	1 = Ready for switching on
ZSW1.1	1 = Ready for operation (DC link loaded, pulses blocked)
ZSW1.2	1 = Operation enabled (drive follows n_set)
ZSW1.3	1 = Fault present
ZSW1.4	1 = No coast down active (OFF2 inactive)
ZSW1.5	1 = No fast stop active (OFF3 inactive)
ZSW1.6	1 = Switching on inhibited active
ZSW1.7	1 = Alarm present
ZSW1.8	1 = Following error within tolerance
ZSW1.9	1 = Control requested
ZSW1.10	1 = Target position reached
ZSW1.11	1 = Reference point set
ZSW1.12	 = Acknowledgement traversing block activated
ZSW1.13	1 = Setpoint fixed
ZSW1.14	1 = Axis accelerated
ZSW1.15	1 = Axis decelerated

8.4.6 ZSW2 status word (for telegrams 9, 110, 111)

Signal	Description
ZSW2.0	Reserved
ZSW2.1	Reserved
ZSW2.2	Reserved
ZSW2.3	Reserved
ZSW2.4	Reserved
ZSW2.5	1 = Alarm class bit 0
ZSW2.6	1 = Alarm class bit 1
ZSW2.7	Reserved
ZSW2.8	1 = Traverse to fixed endstop

Signal	Description
ZSW2.9	Reserved
ZSW2.10	1 = Pulses enabled
ZSW2.11	Reserved
ZSW2.12	Slave sign-of-life, bit 0
ZSW2.13	Slave sign-of-life, bit 1
ZSW2.14	Slave sign-of-life, bit 2
ZSW2.15	Slave sign-of-life, bit 3

8.4.7 G1_ZSW encoder 1 status word

Signal	Description											
G1_ZSW.0	Feedback signal of the active function (1 = function active)											
G1_ZSW.1	<table border="1"> <thead> <tr> <th>Function No.</th> <th>For reference number and flying measurement</th> </tr> </thead> <tbody> <tr> <td>1</td> <td>Reference mark 1 or measuring probe 1 </td> </tr> <tr> <td>2</td> <td>Reference mark 2 or measuring probe 1 </td> </tr> <tr> <td>3</td> <td>Reference mark 3 or measuring probe 2 </td> </tr> <tr> <td>4</td> <td>Reference mark 4 or measuring probe 2 </td> </tr> </tbody> </table>		Function No.	For reference number and flying measurement	1	Reference mark 1 or measuring probe 1 	2	Reference mark 2 or measuring probe 1 	3	Reference mark 3 or measuring probe 2 	4	Reference mark 4 or measuring probe 2 
Function No.			For reference number and flying measurement									
1			Reference mark 1 or measuring probe 1 									
2			Reference mark 2 or measuring probe 1 									
3			Reference mark 3 or measuring probe 2 									
4	Reference mark 4 or measuring probe 2 											
G1_ZSW.2												
G1_ZSW.3												
G1_ZSW.4	1 = Position actual value from function 1	Generated value in Gn_XIST2 (and can be read)										
G1_ZSW.5	1 = Position actual value from function 2											
G1_ZSW.6	1 = Position actual value from function 3											
G1_ZSW.7	1 = Position actual value from function 4											
G1_ZSW.8	Reserved											
G1_ZSW.9	Reserved											
G1_ZSW.10	Reserved											
G1_ZSW.11	1 = Acknowledge encoder fault active											
G1_ZSW.12	Reserved (for reference point offset)											
G1_ZSW.13	Absolute value is cyclically transferred											
G1_ZSW.14	Parking encoder active											
G1_ZSW.15	Encoder fault, the fault is in Gn_XIST2											

8.4.8 MELDW status word

Signal	Description
MELDW.0	1 = Ramp-up/ramp-down complete 0 = Ramp-function generator active
MELDW.1	1 = Torque utilization [%] < torque threshold value 2
MELDW.2	1 = n_act < speed threshold value 3 (p2161)
MELDW.3	1 = n_act ≤ speed threshold value 2
MELDW.4	1 = Vdc_min controller active
MELDW.5	Reserved
MELDW.6	1 = No motor overtemperature alarm
MELDW.7	1 = No alarm, thermal overload, power unit
MELDW.8	1 = Speed setpoint - actual value deviation within tolerance t_on
MELDW.9	Reserved
MELDW.10	Reserved
MELDW.11	1 = Controller enable
MELDW.12	1 = Drive ready
MELDW.13	1 = Pulses enabled
MELDW.14	Reserved
MELDW.15	Reserved

8.4.9 POS_ZSW1 positioning status word

Signal	Description
POS_ZSW1.0	Active Traversing Block Bit 0 (2 ⁰)
POS_ZSW1.1	Active Traversing Block Bit 0 (2 ¹)
POS_ZSW1.2	Active Traversing Block Bit 0 (2 ²)
POS_ZSW1.3	Active Traversing Block Bit 0 (2 ³)
POS_ZSW1.4	Active Traversing Block Bit 0 (2 ⁴)
POS_ZSW1.5	Active Traversing Block Bit 0 (2 ⁵)
POS_ZSW1.6	Reserved
POS_ZSW1.7	Reserved
POS_ZSW1.8	1 = STOP cam minus active
POS_ZSW1.9	1 = STOP cam plus active
POS_ZSW1.10	1 = Jogging active
POS_ZSW1.11	1 = Reference point approach active
POS_ZSW1.12	Reserved
POS_ZSW1.13	1 = Traversing Block active
POS_ZSW1.14	1 = Set-up active
POS_ZSW1.15	1 = MDI active 0 = MDI inactive

8.4.10 POS_ZSW2 positioning status word

Signal	Description
POS_ZSW2.0	1 = Tracking mode active
POS_ZSW2.1	1 = Velocity limiting active
POS_ZSW2.2	1 = Setpoint available
POS_ZSW2.3	Reserved
POS_ZSW2.4	1 = Axis moves forward
POS_ZSW2.5	1 = Axis moves backwards
POS_ZSW2.6	1 = Software limit switch minus reached
POS_ZSW2.7	1 = Software limit switch plus reached
POS_ZSW2.8	1 = Position actual value \leq cam switching position 1
POS_ZSW2.9	1 = Position actual value \leq cam switching position 2
POS_ZSW2.10	1 = Direct output 1 via traversing block
POS_ZSW2.11	1 = Direct output 2 via traversing block
POS_ZSW2.12	1 = Fixed stop reached
POS_ZSW2.13	1 = Fixed stop clamping torque reached
POS_ZSW2.14	1 = Travel to fixed stop active
POS_ZSW2.15	1 = Traversing command active

Safety integrated function

9.1 Standards and regulations

9.1.1 General information

9.1.1.1 Aims

Manufacturers and operating companies of equipment, machines, and products are responsible for ensuring the required level of safety. This means that plants, machines, and other equipment must be designed to be as safe as possible in accordance with the current state of the art. To ensure this, companies describe in the various standards the current state of the art covering all aspects relevant to safety. When the relevant Standards are observed, this ensures that state-of-the-art technology has been utilized and, in turn, the erector/builder of a plant or a manufacturer of a machine or a piece of equipment has fulfilled his appropriate responsibility.

Safety systems are designed to minimize potential hazards for both people and the environment by means of suitable technical equipment, without restricting industrial production and the use of machines more than is necessary. The protection of man and environment must be assigned equal importance in all countries, which is it is important that rules and regulations that have been internationally harmonized are applied. This is also designed to avoid distortions in the competition due to different safety requirements in different countries.

There are different concepts and requirements in the various regions and countries of the world when it comes to ensuring the appropriate degree of safety. The legislation and the requirements of how and when proof is to be given and whether there is an adequate level of safety are just as different as the assignment of responsibilities.

The most important thing for manufacturers of machines and companies that set up plants and systems is that the legislation and regulations in the country where the machine or plant is being operated apply. For example, the control system for a machine that is to be used in the US must fulfill local US requirements even if the machine manufacturer (OEM) is based in the European Economic Area (EEA).

9.1.1.2 Functional safety

Safety, from the perspective of the object to be protected, cannot be split-up. The causes of hazards and, in turn, the technical measures to avoid them can vary significantly. This is why a differentiation is made between different types of safety (e.g. by specifying the cause of possible hazards). "Functional safety" is involved if safety depends on the correct function. To ensure the functional safety of a machine or plant, the safety-related parts of the protection and control devices must function correctly. In addition, the systems must behave in such a way that either the plant remains in a safe state or it is brought into a safe state if a fault occurs. In this case, it is necessary to use specially qualified technology that fulfills the requirements described in the associated Standards. The requirements to achieve functional safety are based on the following basic goals:

- Avoiding systematic faults
- Controlling systematic faults
- Controlling random faults or failures

Benchmarks for establishing whether or not a sufficient level of functional safety has been achieved include the probability of hazardous failures, the fault tolerance, and the quality that is to be ensured by minimizing systematic faults. This is expressed in the Standards using different terms. In IEC/EN 61508, IEC/EN 62061 "Safety Integrity Level" (SIL) and EN ISO 13849-1 "Categories" and "Performance Level" (PL).

9.1.2 Safety of machinery in Europe

The EU Directives that apply to the implementation of products are based on Article 95 of the EU contract, which regulates the free exchange of goods. These are based on a new global concept ("new approach", "global approach"):

- EU Directives only specify general safety goals and define basic safety requirements.
- Technical details can be defined by means of standards by Standards Associations that have the appropriate mandate from the commission of the European Parliament and Council (CEN, CENELEC). These standards are harmonized in line with a specific directive and listed in the official journal of the commission of the European Parliament and Council. Legislation does not specify that certain standards have to be observed. When the harmonized Standards are observed, it can be assumed that the safety requirements and specifications of the Directives involved have been fulfilled.
- EU Directives specify that the Member States must mutually recognize domestic regulations.

The EU Directives are equal. This means that if several Directives apply for a specific piece of equipment or device, the requirements of all of the relevant Directives apply (e.g. for a machine with electrical equipment, the Machinery Directive and the Low-Voltage Directive apply).

9.1.2.1 Machinery Directive

The basic safety and health requirements specified in Annex I of the Directive must be fulfilled for the safety of machines.

The protective goals must be implemented responsibly to ensure compliance with the Directive.

Manufacturers of a machine must verify that their machine complies with the basic requirements. This verification is facilitated by means of harmonized standards.

9.1.2.2 Harmonized European Standards

The two Standards Organizations CEN (Comité Européen de Normalisation) and CENELEC (Comité Européen de Normalisation Électrotechnique), mandated by the EU Commission, drew-up harmonized European standards in order to precisely specify the requirements of the EC directives for a specific product. These standards (EN standards) are published in the official journal of the commission of the European Parliament and Council and must be included without revision in domestic standards. They are designed to fulfill basic health and safety requirements as well as the protective goals specified in Annex I of the Machinery Directive.

When the harmonized standards are observed, it is "automatically assumed" that the Directive is fulfilled. As such, manufacturers can assume that they have observed the safety aspects of the Directive under the assumption that these are also covered in this standard. However, not every European Standard is harmonized in this sense. Key here is the listing in the official journal of the commission of the European Parliament and Council.

The European Safety of Machines standard is hierarchically structured. It is divided into:

- A standards (basic standards)
- B standards (group standards)
- C standards (product standards)

Type A standards/basic standards

A standards include basic terminology and definitions relating to all types of machine. This includes EN ISO 12100-1 (previously EN 292-1) "Safety of Machines, Basic Terminology, General Design Principles".

A standards are aimed primarily at the bodies responsible for setting the B and C standards. The measures specified here for minimizing risk, however, may also be useful for manufacturers if no applicable C standards have been defined.

Type B standards/group standards

B standards cover all safety-related standards for various different machine types. B standards are aimed primarily at the bodies responsible for setting C standards. They can also be useful for manufacturers during the machine design and construction phases, however, if no applicable C standards have been defined.

A further sub-division has been made for B standards:

- Type B1 standards for higher-level safety aspects (e.g. ergonomic principles, safety clearances from sources of danger, minimum clearances to prevent parts of the body from being crushed).
- Type B2 standards for protective safety devices are defined for different machine types (e.g. EMERGENCY STOP devices, two-hand operating circuits, interlocking elements, contactless protective devices, safety-related parts of controls).

Type C standards/product standards

C standards are product-specific standards (e.g. for machine tools, woodworking machines, elevators, packaging machines, printing machines etc.). Product standards cover machine-specific requirements. The requirements can, under certain circumstances, deviate from the basic and group standards. Type C/product standards have the highest priority for machine manufacturers who can assume that it fulfills the basic requirements of Annex I of the Machinery Directive (automatic presumption of compliance). If no product standard has been defined for a particular machine, type B standards can be applied when the machine is constructed.

A complete list of the standards specified and the mandated draft standards are available on the Internet at the following address:

<http://www.newapproach.org/>

Recommendation: Due to the rapid pace of technical development and the associated changes in machine concepts, the standards (and C standards in particular) should be checked to ensure that they are up to date. Please note that the application of a particular standard may not be mandatory provided that all the safety requirements of the applicable EU directives are fulfilled.

9.1.2.3 Standards for implementing safety-related controllers

If the functional safety of a machine depends on various control functions, the controller must be implemented in such a way that the probability of the safety functions failing is sufficiently minimized. EN ISO 13849-1 and EN IEC61508 define principles for implementing safety-related machine controllers which, when properly applied, ensure that all the safety requirements of the EC Machinery Directive are fulfilled. These standards ensure that the relevant safety requirements of the Machinery Directive are fulfilled.

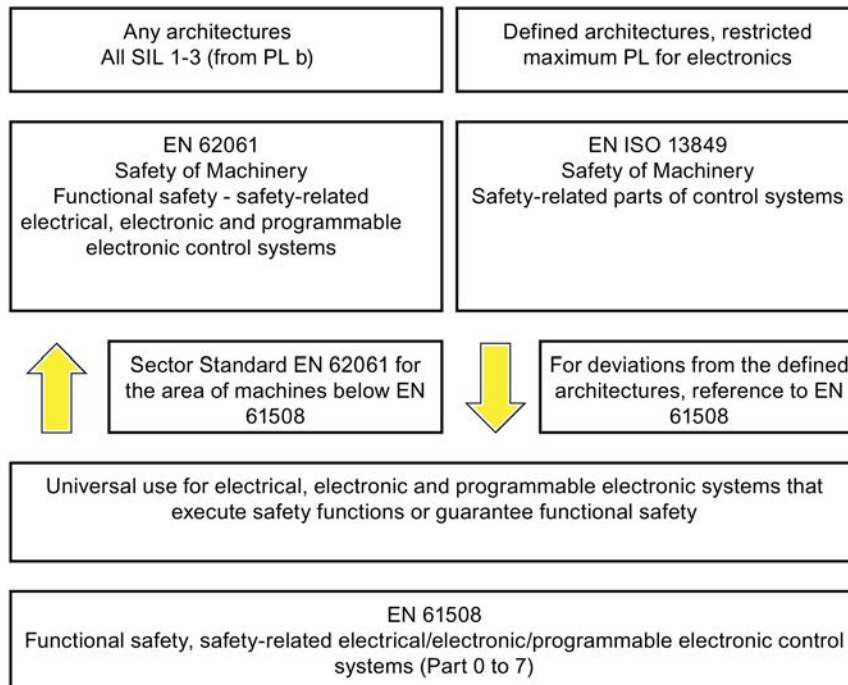

The application areas of EN ISO 13849-1, EN 62061, and EN 61508 are very similar. To help users make an appropriate decision, the IEC and ISO associations have specified the application areas of both standards in a joint table in the introduction to the standards. EN ISO 13849-1 or EN 62061 should be applied depending on the technology (mechanics, hydraulics, pneumatics, electrics, electronics and programmable electronics), risk classification and architecture.

Type	Systems for executing safety-related control functions	EN ISO 13849-1	EN 62061
A	Non-electrical (e.g. hydraulic, pneumatic)	X	Not covered
B	Electromechanical (e.g. relay and/or basic electronics)	Restricted to the designated architectures (see comment 1) and max. up to PL = e	All architectures and max. up to SIL 3
C	Complex electronics (e.g. programmable electronics)	Restricted to the designated architectures (see comment 1) and max. up to PL = d	All architectures and max. up to SIL 3
D	A standards combined with B standards	Restricted to the designated architectures (see comment 1) and max. up to PL = e	X See comment 3
E	C standards combined with B standards	Restricted to the designated architectures (see comment 1) and max. up to PL = d	All architectures and max. up to SIL 3
F	C standards combined with A standards or C standards combined with A standards and B standards	X See comment 2	X See comment 3
<p>"X" indicates that the point is covered by this standard.</p> <p>Comment 1: Designated architectures are described in Annex B of EN ISO 13849-1 and provide a simplified basis for the quantification.</p> <p>Comment 2: For complex electronics: Using designated architectures in compliance with EN ISO 13849-1 up to PL = d or every architecture in compliance with EN 62061.</p> <p>Comment 3: For non-electrical systems: Use components that comply with EN ISO 13849-1 as sub-systems.</p>			

9.1.2.4 DIN EN ISO 13849-1

A qualitative analysis according to DIN ISO EN 13849-1 is not sufficient for modern control systems due to their technology. Among other things, DIN EN ISO 13849-1 does not take into account time behavior (e.g. test interval and/or cyclic test, lifetime). This results in the probabilistic approach in DIN EN ISO 13849-1 (probability of failure per unit time). DIN EN ISO 13849-1 takes into account complete safety functions and all the devices required to execute these. With DIN EN ISO 13849-1, safety functions are investigated from the qualitative perspective as well as the quantitative perspective. Performance levels (PL), which are based on the categories, are used. The following safety-related characteristic quantities are required for devices/equipment:

- Category (structural requirement)
- PL: Performance level

- MTTF_d: Mean time to dangerous failure
- DC: Diagnostic coverage
- CCF: Common cause failure

The standard describes how the performance level (PL) is calculated for safety-related components of the controller on the basis of designated architectures. In the event of any deviations from this, EN ISO 13849-1 refers to EN 61508.

When combining several safety-related parts to form a complete system, the standard explains how to determine the resulting PL.

Note

DIN EN ISO 13849-1 and machinery directive

Since May 2007, DIN EN ISO 13849-1 has been harmonized as part of the Machinery Directive.

9.1.2.5 EN 62061

EN 62061 (identical to IEC 62061) is a sector-specific standard subordinate to IEC/EN 61508. It describes the implementation of safety-related electrical machine control systems and looks at the complete life cycle, from the conceptual phase to decommissioning. The standard is based on the quantitative and qualitative analyses of safety functions, whereby it systematically applies a top-down approach to implementing complex control systems (known as "functional decomposition"). The safety functions derived from the risk analysis are sub-divided into sub-safety functions, which are then assigned to real devices, sub-systems, and sub-system elements. Both the hardware and software are covered. EN 62061 also describes the requirements placed on implementing application programs.

A safety-related control system comprises different sub-systems. From a safety perspective, the sub-systems are described in terms of the SIL claim limit and PFHD characteristic quantities.

Programmable electronic devices (e.g. PLCs or variable-speed drives) must fulfill EN 61508. They can then be integrated in the controller as sub-systems. The following safety-related characteristic quantities must be specified by the manufacturers of these devices.

Safety-related characteristic quantities for subsystems:

- SIL CL: SIL claim limit
- PFHD: Probability of dangerous failures per hour
- T1: Lifetime

Simple sub-systems (e.g. sensors and actuators) in electromechanical components can, in turn, comprise sub-system elements (devices) interconnected in different ways with the characteristic quantities required for determining the relevant PFHD value of the sub-system.

Safety-related characteristic quantities for subsystem elements (devices):

- λ : Failure rate
- B10 value: For elements that are subject to wear
- T1: Lifetime

For electromechanical devices, a manufacturer specifies a failure rate λ with reference to the number of operating cycles. The failure rate per unit time and the lifetime must be determined using the switching frequency for the particular application.

Parameters for the sub-system, which comprises sub-system elements, that must be defined during the design phase:

- T2: Diagnostic test interval
- β : Susceptibility to common cause failure
- DC: Diagnostic coverage

The PFHD value of the safety-related controller is determined by adding the individual PFHD values for subsystems.

The user has the following options when setting up a safety-related controller:

- Use devices and sub-systems that already comply with EN ISO 13849-1, IEC/EN 61508, or IEC/EN 62061. The standard provides information specifying how qualified devices can be integrated when safety functions are implemented.
- Develop own subsystems:
 - Programmable, electronic systems and complex systems: Application of EN 61508 or EN 61800-5-2.
 - Simple devices and subsystems: Application of EN 62061.

EN 62061 does not include information about non-electric systems. The standard provides detailed information on implementing safety-related electrical, electronic, and programmable electronic control systems. EN ISO 13849-1 must be applied for non-electric systems.

Note

Function examples

Details of simple sub-systems that have been implemented and integrated are now available as "functional examples".

Note

EN 62061 and machinery directive

IEC 62061 has been ratified as EN 62061 in Europe and harmonized as part of the Machinery Directive.

9.1.2.6 Series of standards EN 61508 (VDE 0803)

This series of standards describes the current state of the art.

EN 61508 is not harmonized in line with any EU directives, which means that an automatic presumption of conformity for fulfilling the protective requirements of a directive is not implied. The manufacturer of a safety-related product, however, can also use EN 61508 to fulfill basic requirements of European directives in accordance with the latest conceptual design, for example, in the following cases:

- If no harmonized standard exists for the application in question. In this case, the manufacturer can use EN 61508, although no presumption of conformity exists here.
- A harmonized European standard (e.g. EN 62061, EN ISO 13849, EN 60204-1) references EN 61508. This ensures that the appropriate requirements of the directives are fulfilled ("standard that is also applicable"). When manufacturers apply EN 61508 properly and responsibly in accordance with this reference, they can use the presumption of conformity of the referencing standard.

EN 61508 covers all the aspects that must be taken into account when E/E/PES systems (electrical, electronic, and programmable electronic System) are used in order to execute safety functions and/or to ensure the appropriate level of functional safety. Other hazards (e.g. electric shock) are, as in EN ISO 13849, not part of the standard.

EN 61508 has recently been declared the "International Basic Safety Publication", which makes it a framework for other, sector-specific standards (e.g. EN 62061). As a result, this standard is now accepted worldwide, particularly in North America and in the automotive industry. Today, many regulatory bodies already stipulate it (e.g. as a basis for NRTL listing).

Another recent development with respect to EN 61508 is its system approach, which extends the technical requirements to include the entire safety installation from the sensor to the actuator, the quantification of the probability of hazardous failure due to random hardware failures, and the creation of documentation covering all phases of the safety-related lifecycle of the E/E/PES.

9.1.2.7 Risk analysis/assessment

Risks are intrinsic in machines due to their design and functionality. For this reason, the Machinery Directive requires that a risk assessment be performed for each machine and, if necessary, the level of risk reduced until the residual risk is less than the tolerable risk. To assess these risks, the following standards must be applied:

EN ISO 12100-1 "Safety of Machinery - basic terminology, general principles for design"

EN ISO 13849-1 "Safety-related parts of control systems"

EN ISO 12100-1 focuses on the risks to be analyzed and the design principles for minimizing risk.

The risk assessment is a procedure that allows hazards resulting from machines to be systematically investigated. Where necessary, the risk assessment is followed by a risk reduction procedure. When the procedure is repeated, this is known as an iterative process. This can help eliminate hazards (as far as this is possible) and can act as a basis for implementing suitable protective measures.

The risk assessment involves the following:

- Risk analysis
 - Determines the limits of the machine (EN ISO 12100-1)
 - Identification of the hazards (EN ISO 12100-114)
 - Estimating the level of risk (EN 1050 Paragraph 7)
- Risk evaluation

As part of the iterative process to achieve the required level of safety, a risk assessment is carried out after the risk estimation. A decision must be made here as to whether the residual risk needs to be reduced. If the risk is to be further reduced, suitable protective measures must be selected and applied. The risk assessment must then be repeated.

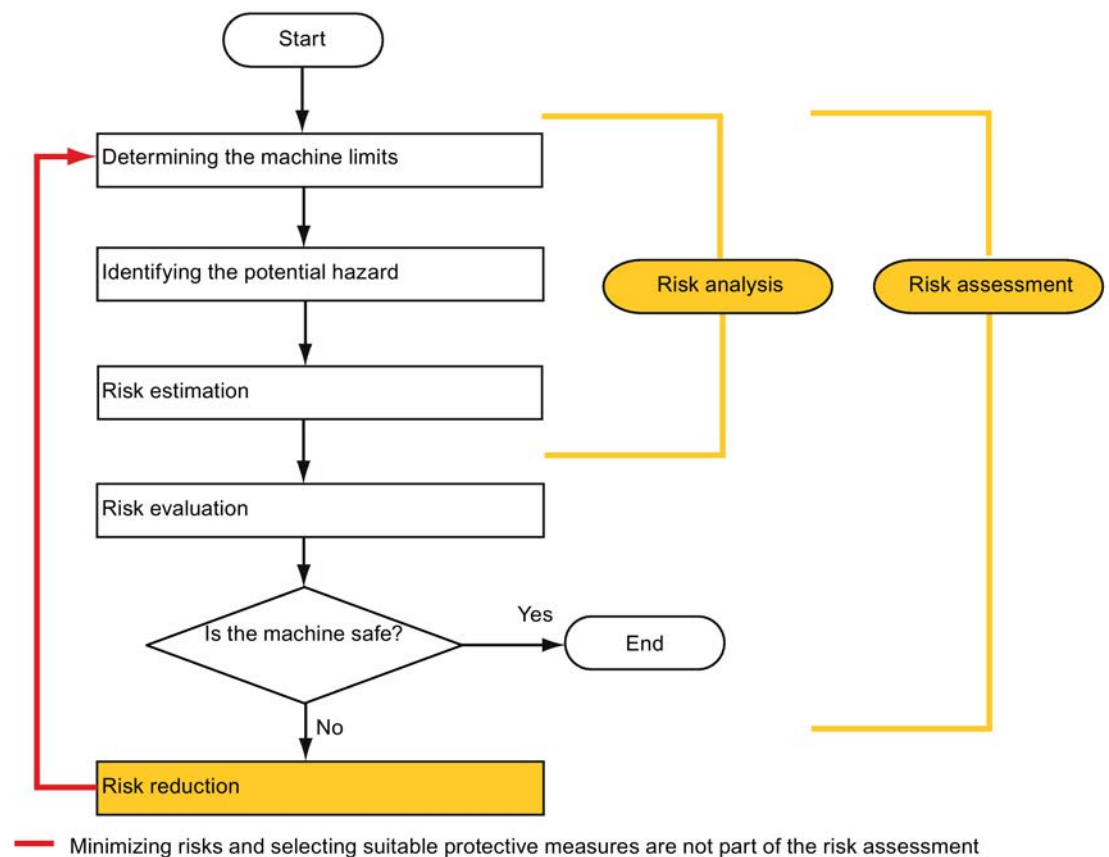

Risks must be reduced by designing and implementing the machine accordingly (e.g. by means of controllers or protective measures suitable for the safety-related functions).

If the protective measures involve the use of interlocking or control functions, these must be designed according to EN ISO 13849-1. For electrical and electronic controllers, EN 62061 can be used as an alternative to EN ISO 13849-1. Electronic controllers and bus systems must also comply with IEC/EN 61508.

9.1.2.8 Risk reduction

Risk reduction measures for a machine can be implemented by means of safety-related control functions in addition to structural measures. To implement these control functions, special requirements must be taken into account, graded according to the magnitude of the risk. These are described in EN ISO 13849-1 or, in the case of electrical controllers (particularly programmable electronics), in EN 61508 or EN 62061. The requirements regarding safety-related controller components are graded according to the magnitude of the risk and the level to which the risk needs to be reduced.

EN ISO 13849-1 defines a risk flow chart that instead of categories results in hierarchically graduated Performance Levels (PL).

IEC/EN 62061 uses "Safety Integrity Level" (SIL) for classification purposes. This is a quantified measure of the safety-related performance of a controller. The required SIL is also determined in accordance with the risk assessment principle according to ISO 12100 (EN 1050). Annex A of the standard describes a method for determining the required Safety Integrity Level (SIL).

Regardless of which standard is applied, steps must be taken to ensure that all the machine controller components required for executing the safety-related functions fulfill these requirements.

9.1.2.9 Residual risk

In today's technologically advanced world, the concept of safety is relative. The ability to ensure safety to the extent that risk is ruled out in all circumstances – "zero-risk guarantee" – is practically impossible. The residual risk is the risk that remains once all the relevant protective measures have been implemented in accordance with the latest state of the art.

Residual risks must be clearly referred to in the machine/plant documentation (user information according to EN ISO 12100-2).

9.1.3 Machine safety in the USA

A key difference between the USA and Europe in the legal requirements regarding safety at work is that, in the USA, no legislation exists regarding machinery safety that is applicable in all of the states and that defines the responsibility of the manufacturer/supplier. A general requirement exists stating that employers must ensure a safe workplace.

9.1.3.1 Minimum requirements of the OSHA

The Occupational Safety and Health Act (OSHA) from 1970 regulates the requirement that employers must offer a safe place of work. The core requirements of OSHA are specified in Section 5 "Duties".

The requirements of the OSH Act are managed by the "Occupational Safety and Health Administration" (also known as OSHA). OSHA employs regional inspectors who check whether or not workplaces comply with the applicable regulations.

The OSHA regulations are described in OSHA 29 CFR 1910.xxx ("OSHA Regulations (29 CFR) PART 1910 Occupational Safety and Health"). (CFR: Code of Federal Regulations.)

<http://www.osha.gov>

The application of standards is regulated in 29 CFR 1910.5 "Applicability of standards". The concept is similar to that used in Europe. Product-specific standards have priority over general standards insofar as they cover the relevant aspects. Once the standards are fulfilled, employers can assume that they have fulfilled the core requirements of the OSH Act with respect to the aspects covered by the standards.

In conjunction with certain applications, OSHA requires that all electrical equipment and devices that are used to protect workers be authorized by an OSHA-certified, "Nationally Recognized Testing Laboratory" (NRTL) for the specific application.

In addition to the OSHA regulations, the current standards defined by organizations such as NFPA and ANSI must be carefully observed and the extensive product liability legislation that exists in the US taken into account. Due to the product liability legislation, it is in the interests of manufacturing and operating companies that they carefully maintain the applicable regulations and are "forced" to fulfill the requirement to use state-of-the-art technology.

Third-party insurance companies generally demand that their customers fulfill the applicable standards of the standards organizations. Self-insured companies are not initially subject to this requirement but, in the event of an accident, they must provide verification that they have applied generally-recognized safety principles.

9.1.3.2 NRTL listing

To protect employees, all electrical equipment used in the USA must be certified for the planned application by a "Nationally Recognized Testing Laboratory" (NRTL) certified by the OSHA. NRTLs are authorized to certify equipment and material by means of listing, labeling, or similar. Domestic standards (e.g. NFPA 79) and international standards (e.g. IEC/EN 61508 for E/E/PES systems) are the basis for testing.

9.1.3.3 NFPA 79

Standard NFPA 79 (Electrical Standard for Industrial Machinery) applies to electrical equipment on industrial machines with rated voltages of less than 600 V. A group of machines that operate together in a coordinated fashion is also considered to be one machine.

For programmable electronics and communication buses, NFPA 79 states as a basic requirement that these must be listed if they are to be used to implement and execute safety-related functions. If this requirement is fulfilled, then electronic controls and communication buses can also be used for Emergency Stop functions, Stop Categories 0 and 1 (refer to NFPA 79 9.2.5.4.1.4). Like EN 60204-1, NFPA 79 no longer specifies that the electrical energy must be disconnected by electromechanical means for emergency stop functions.

The core requirements regarding programmable electronics and communication buses are: system requirements (see NFPA 79 9.4.3)

1. Control systems that contain software-based controllers must:
 - In the event of a single fault
 - cause the system to switch to a safe shutdown mode
 - prevent the system from restarting until the fault has been rectified
 - prevent an unexpected restart
 - Offer the same level of protection as hard-wired controllers
 - Be implemented in accordance with a recognized standard that defines the requirements for such systems.
2. IEC 61508, IEC 62061, ISO 13849-1, ISO 13849 2 and IEC 61800-5-2 are specified as suitable standards in a note.

Underwriter Laboratories Inc. (UL) has defined a special category for "Programmable Safety Controllers" for implementing this requirement (code NRGF). This category covers control devices that contain software and are designed for use in safety-related functions.

A precise description of the category and a list of devices that fulfill this requirement can be found on the Internet at the following address:

<http://www.ul.com> → certifications directory → UL Category code/ Guide information → search for category "NRGF"

TUV Rheinland of North America, Inc. is also an NRTL for these applications.

9.1.3.4 ANSI B11

ANSI B11 standards are joint standards developed by associations such as the Association for Manufacturing Technology (AMT) and the Robotic Industries Association (RIA).

The hazards of a machine are evaluated by means of a risk analysis/assessment. The risk analysis is an important requirement in accordance with NFPA 79, ANSI/RIA 15.06, ANSI B11.TR-3 and SEMI S10 (semiconductors). The documented findings of a risk analysis can be used to select a suitable safety system based on the safety class of the application in question.

The situation in Japan is different from that in Europe and the US. Legislation such as that prescribed in Europe does not exist. Similarly, product liability does not play such an important role as it does in the US.

Instead of legal requirements to apply standards have been defined, an administrative recommendation to apply JIS (Japanese Industrial Standard) is in place: Japan bases its approach on the European concept and uses basic standards as national standards (see table).

Japanese standards

ISO/IEC number	JIS number	Comment
ISO12100-1	JIS B 9700-1	Earlier designation TR B 0008
ISO12100-2	JIS B 9700-2	Earlier designation TR B 0009
ISO14121- 1 / EN1050	JIS B 9702	
ISO13849- 1	JIS B 9705-1	

ISO/IEC number	JIS number	Comment
ISO13849- 2	JIS B 9705-1	
IEC 60204-1	JIS B 9960-1	Without annex F or route map of the European foreword
IEC 61508-0 to -7	JIS C 0508	
IEC 62061		JIS number not yet assigned

In addition to the requirements of the guidelines and standards, company-specific requirements must be taken into account. Large corporations in particular (e.g. automobile manufacturers) make stringent demands regarding automation components, which are often listed in their own equipment specifications.

Safety-related issues (e.g. operating modes, operator actions with access to hazardous areas, EMERGENCY STOP concepts, etc.) should be clarified with customers early on so that they can be integrated in the risk assessment/risk reduction process.

9.1.4 Machine safety in Japan

The situation in Japan is different from that in Europe and the US. Legislation such as that prescribed in Europe does not exist. Similarly, product liability does not play such an important role as it does in the US.

Instead of legal requirements to apply standards have been defined, an administrative recommendation to apply JIS (Japanese Industrial Standard) is in place: Japan bases its approach on the European concept and uses basic standards as national standards (see table).

Japanese standards

ISO/IEC number	JIS number	Comment
ISO12100-1	JIS B 9700-1	Earlier designation TR B 0008
ISO12100-2	JIS B 9700-2	Earlier designation TR B 0009
ISO14121- 1 / EN1050	JIS B 9702	
ISO13849-1	JIS B 9705-1	
ISO13849-2	JIS B 9705-1	
IEC 60204-1	JIS B 9960-1	Without annex F or route map of the European foreword
IEC 61508-0 to -7	JIS C 0508	
IEC 62061		JIS number not yet assigned

9.1.5 Equipment regulations

In addition to the requirements of the guidelines and standards, company-specific requirements must be taken into account. Large corporations in particular (e.g. automobile manufacturers) make stringent demands regarding automation components, which are often listed in their own equipment specifications.

Safety-related issues (e.g. operating modes, operator actions with access to hazardous areas, EMERGENCY STOP concepts, etc.) should be clarified with customers early on so that they can be integrated in the risk assessment/risk reduction process.

9.2 General information about SINAMICS Safety Integrated

Safety Integrated function - STO

The Safe Torque Off (STO) is a safety function that prevents the drive from restarting unexpectedly, in accordance with EN 60204-1:2006 Section 5.4.

The STO function is in conformance with the IEC 61508, SIL2 standard, in the operating mode with a high demand, Category 3 and Performance Level d (PL d) acc. to ISO 13849-1:2015, as well as IEC 61800-5-2.

Controlling the STO Function

The STO function can be controlled via terminals. For the details about STO wiring, refer to the chapter "24 V power supply/STO (Page 110)".

9.3 System features

9.3.1 STO functional safety data

The STO functional safety data of SINAMICS V90 PN is as follows:

Applied standards	IEC 61508, IEC 62061, ISO 13849-1
Type	A
Safety Integrity Level (SIL)	2
Hardware Fault Tolerance (HFT)	1
Probability of Failure per Hour (PFH)	5×10^{-8} per hour

9.3.2 Certification

The safety function of the SINAMICS V90 PN drive system meets the following requirements:

- Category 3 according to ISO 13849-1:2015
- Performance Level (PL) d to ISO 13849-1:2015
- Safety integrity level 2 (SIL 2) to IEC 61508

In addition, the safety function of SINAMICS V90 PN has been certified by independent institutes. An up-to-date list of certified components is available on request from your local Siemens office.

9.3.3 Safety instructions

Note

Residual risks not specified in this section are included in the chapter "Fundamental safety instructions (Page 11)".

DANGER

Death or serious injury resulting from failure to observe the Safety Integrated instructions

Safety Integrated can be used to minimize the level of risk associated with machines and plants. Failure to observe the Safety Integrated instructions. Machines and plants can only be operated safely in conjunction with Safety Integrated when the machine manufacturer is familiar with and observes every aspect of this technical user documentation, including the documented general conditions, safety information, and residual risks.

- Precisely knows and observes this technical user documentation - including the documented limitations, safety information and residual risks;
- Carefully constructs and configures the machine/plant. A careful and thorough acceptance test must then be performed by qualified personnel and the results documented.
- Implements and validates all the measures required in accordance with the machine/plant risk analysis by means of the programmed and configured Safety Integrated functions or by other means.
- The use of Safety Integrated does not replace the machine/plant risk assessment carried out by the machine manufacturer as required by the EC machinery directive.
- In addition to using Safety Integrated functions, further risk reduction measures must be implemented.

WARNING

Failure to activate the Safety Integrated function due to system not startup

The Safety Integrated functions cannot be activated until the system has been completely powered up. System startup is a critical operating state with increased risk. To start up the system, you need to make sure that the following requirements are fulfilled.

- No personnel is present in the immediate danger zone in this phase.
- The drives of vertical axes must be in torque state.
- A complete forced dormant error detection cycle is required after power on.

 WARNING
Personal injury or device damage due to improper operations of the Emergency Stop function
There is a personal injury or device damage if you use the Emergency Stop function improperly. According to the standard EN 60204-1:2006, Emergency Stop function must bring the machine to a standstill in accordance with STO.
<ul style="list-style-type: none">• Make sure that, if you use the Emergency Stop function to shut down the machine, the machine is not allowed to restart automatically after EMERGENCY STOP.• When the safety function is deactivated, an automatic restart is permitted under certain circumstances depending on the risk analysis (except when Emergency Stop is reset). For example, an automatic start is permitted when a protective door is closed.

 WARNING
Personal injury or device damage due to improper operations after the hardware and/or software components change
After hardware and/or software components have been modified or replaced, all protective equipment must be closed prior to system startup and drive activation; otherwise, personal injury or device damage occur.
<ul style="list-style-type: none">• No personnel is present within the danger zone.• Before allowing anybody to re-enter the danger zone, you should test steady control response by briefly moving the drives in forward and reverse direction (+/-).• To use Safety Integrated functions, you need to make sure that the system has completely powered up.

9.3.4 Probability of failure of the safety function

Probability of failure per hour (PFH)

The probability of the failure of safety functions must be specified in the form of a PFH value in accordance with IEC 61508, IEC 62061, and ISO 13849-1:2015. The PFH value of a safety function depends on the safety concept of the drive unit and its hardware configuration, as well as on the PFH values of other components used for this safety function.

Corresponding PFH values are provided for the SINAMICS V90 PN drive system, depending on the hardware configuration (number of drives, control type, number of encoders used). The various integrated safety functions are not differentiated.

The PFH value of SINAMICS V90 PN drive system is 5×10^{-8} per hour.

Hardware fault tolerance (HFT)

The HFT value of SINAMICS V90 PN drive system is one. It means that the system can handle one fault without brake down. SINAMICS V90 PN STO function is a subsystem from type A, and only the discrete components are involved in the STO function.

9.3.5 Response time

Response time means the time from the control via terminals until the response actually occurs. For 200 V variant servo drives, the STO response time in the worst case is 15 ms. For 400 V variant servo drives, the STO response time in the worst case is 5 ms. The response time of fault reaction functions is 2 s.

9.3.6 Residual risk

The fault analysis enables the machine manufacturer to determine the residual risk at this machine with regard to the drive unit. The following residual risks are known:

 WARNING
Personal injury or device damage due to the intrinsic potential of hardware faults
Due to the intrinsic potential of hardware faults, electrical systems are subject to additional residual risk, which can be expressed by means of the PFH value.
<ul style="list-style-type: none">• Take into account these residual risks when designing your machine and where necessary apply suitable countermeasures.

 WARNING
Personal injury or device damage resulting from the simultaneous failure of two power transistors in the inverter
Simultaneous failure of two power transistors (one in the upper and the other offset in the lower inverter bridge) in the drive may cause brief movement of the drive which can result in a personal injury or device damage. The movement depends on the number of poles of the motor. For a synchronous rotary motor, the maximum movement is 180 °/No. of pole pairs
<ul style="list-style-type: none">• Take suitable measures to prevent unexpected drive movement, for example, by using a brake equipped with safety monitoring.

9.4 Safety Integrated basic function

9.4.1 Safe Torque Off (STO)

In conjunction with a machine function or in the event of a fault, the "Safe Torque Off" (STO) function is used to safely disconnect and de-energize the torque-generating energy feed to the motor.

When the function is selected, the drive unit is in a "safe status". The switching on inhibited function prevents the drive unit from being restarted.

The two-channel pulse suppression function integrated in the Motor Modules/power units is a basis for this function.

Functional features of "Safe Torque Off"

- This function is integrated in the drive; this means that a higher-level controller is not required.
- The function is drive-specific, i.e. it is available for each drive and must be individually commissioned.
- When the "Safe Torque Off" function is selected, the following applies:
 - The motor cannot be started accidentally.
 - The pulse suppression safely disconnects the torque-generating energy feed to the motor.
 - The power unit and motor are not electrically isolated.
- By selecting/deselecting STO, the safety messages are automatically withdrawn.

The STO function can be used wherever the drive naturally reaches a standstill due to load torque or friction in a sufficiently short time or when "coasting down" of the drive will not have any relevance for safety.

WARNING

Personal injury or device damage resulting from the unexpected movement of the motor after the energy feed is disconnected

The motor may have an undesired movement once the energy feed has been disconnected. This may lead to a personal injury or device damage.

- Take appropriate measures to ensure that the motor does not undesirably move in this case, e.g. against coasting down.

CAUTION

Personal injury or device damage resulting from the simultaneous failure of two power transistors in the inverter

If two power transistors (one in the upper and one in the lower bridge) simultaneously fail in the drive, this can cause brief momentary movement. For a synchronous rotary motor, the maximum movement is 180 °/No. of pole pairs. For a synchronous linear motor, the maximum movement is the pole width.

- Take suitable measures to prevent unexpected drive movement, for example, by using a brake equipped with safety monitoring.

Note

Closing delay of the holding brake

The closing signal (low level) of the holding brake is output 30 ms after the STO is triggered.

Preconditions for using the STO function

When use the STO function, the following preconditions should be fulfilled:

- Each monitoring channel (STO1 and STO2) triggers safe pulse suppression with its switch off signal path.
- If a motor holding brake is connected and configured, the connected brake is not safe because there is no safety function for brake, such as safe brake.

Behaviors of the STO function

Terminal		State	Action
STO1	STO2		
High level	High level	Safe	The servo motor can normally run when you power on the servo drive.
Low level	Low level	Safe	The servo drive starts up normally but the servo motor cannot run.
High level	Low level	Unsafe	Fault F1611 occurs and servo motor coasts down (OFF2).
Low level	High level	Unsafe	Fault F1611 occurs and servo motor coasts down (OFF2).

Selecting/deselecting "Safe Torque Off"

The following is executed when "Safe Torque Off" is selected:

- Each monitoring channel triggers safe pulse suppression via its switch-off signal path.
- A motor holding brake is closed (if connected and configured).

Note

If "Safe Torque Off" is selected and de-selected through one channel within 2 seconds, the pulses are suppressed without a message being output.

Restart after the "Safe Torque Off" function has been selected

1. Deselect the function in each monitoring channel via the input terminals.
2. Issue drive enable signals.
3. Switch the drive back on.
 - 1/0 edge at input signal "ON/OFF1"
 - 0/1 edge at input signal "ON/OFF1" (switch on drive)
4. Operate the drives again.

Response time for the "Safe Torque Off" function

For 200 V variant servo drives, the STO response time in the worst case is 15 ms. For 400 V variant servo drives, the STO response time in the worst case is 5 ms.

9.4.2 Forced dormant error detection

Forced dormant error detection or test of the switch-off signal paths for Safety Integrated basic functions

The forced dormant error detection function at the switch-off signal paths is used to detect software/hardware faults at both monitoring channels in time and is automated by means of activation/deactivation of the "Safe Torque Off" function.

To fulfill the requirements of ISO 13849-1:2015 regarding timely error detection, the two switch-off signal paths must be tested at least once within a defined time to ensure that they are functioning properly. This functionality must be implemented by means of forced dormant error detection function, triggered either in manual mode or by the automated process.

A timer ensures that forced dormant error detection is carried out as quickly as possible.

8760 hours for the forced dormant error detection.

Once this time has elapsed, an alarm is output and remains present until forced dormant error detection is carried out.

The timer returns to the set value each time the STO function is deactivated.

When the appropriate safety devices are implemented (e.g. protective doors), it can be assumed that running machinery will not pose any risk to personnel. For this reason, only an alarm is output to inform the user that a forced dormant error detection run is due and to request that this be carried out at the next available opportunity. This alarm does not affect machine operation.

Examples of when to carry out forced dormant error detection:

- When the drives are at a standstill after the system has been switched on (POWER ON).
- When the protective door is opened.
- At defined intervals.
- In automatic mode (time and event dependent)

Note

The timer will be reset if the associated forced dormant error detection is executed. The corresponding alarm is not triggered.

The forced dormant error detection procedure of Safety Function (STO) always has to be executed through the terminals.

Tuning

10.1 Controller overview

The SINAMICS V90 PN servo drive consists of three control loops:

- Current control
- Speed control
- Position control

The following block diagram shows the relationship between these three control loops:

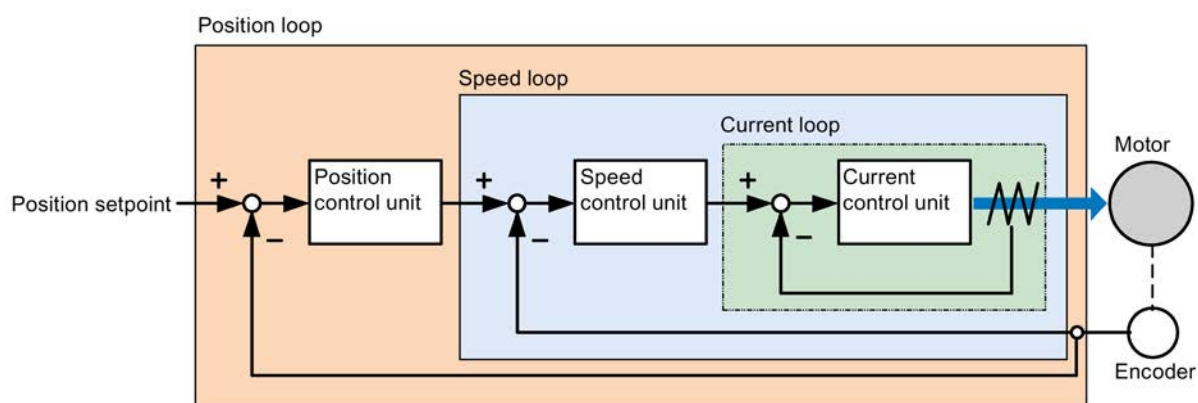

In theory, frequency width of the inside control loop **must** be wider than that of the outer control loop; otherwise, the whole control system can vibrate or have a low response level. The relationship between the frequency widths of these three control loops is as follows:

Current loop > speed loop > position loop

Since the current loop of SINAMICS V90 PN servo drive already has a perfect frequency width, it is only necessary for you to adjust the speed loop gain and the position loop gain.

Servo gains

- Position loop gain

Position loop gain directly influences the response level of the position loop. If the mechanical system does not vibrate or produce noises, you can increase the value of position loop gain so that the response level can be increased and positioning time can be shortened.

Parameter	Value range	Default value	Unit	Description
p29110	0.00 to 300.00	1.8	1000/min	Position loop gain

- Speed loop gain

Speed loop gain directly influences the response level of the speed loop. If the mechanical system does not vibrate or produce noises, you can increase the value of speed loop gain so that the response level can be increased.

Parameter	Value range	Default value	Unit	Description
p29120	0 to 999999.00	0.3	Nms/rad	Speed loop gain

- Speed loop integral gain

With adding integral component into speed loop, the servo drive can efficiently eliminate the steady-state error of speed and give response to a small change to speed.

Generally speaking, if the mechanical system does not vibrate or produce noises, you can decrease speed loop integral gain so that the system rigidity can be increased.

If the load inertia ratio is very high or the mechanical system has a resonance factor, it must be guaranteed that the speed loop integral time constant is big enough; otherwise, the mechanical system may have a resonance.

Parameter	Value range	Default value	Unit	Description
p29121	0 to 100000.00	15	ms	Speed loop integral time
p29022	1 to 10000	1	-	Tuning: Ratio of total inertia moment to motor inertia moment

- Position loop feed forward gain

With position loop feed forward gain, the responsiveness level can be increased. If the position loop feed forward gain is too big, motor speed can have overshoots and the digital output signal INP can have a repeated on/off. You, therefore, must monitor the changes to speed waveform and the action of the digital output signal INP during adjustment. You can slowly adjust the position loop feed forward gain. The effect of feed forward function is not obvious if the position loop gain is too big.

Parameter	Value range	Default value	Unit	Description
p29111	0 to 200	0	%	Speed pre-control factor (feed forward)

10.2 Tuning mode

Responsivity of a machine can be optimized by tuning. The responsivity is reflected by dynamic factor and determined by the servo gains that is set in the servo drive.

The servo gains are set by using a combination of parameters. These parameters influence each other so you must consider the balance between set values when setting these values.

Generally, the responsivity of a machine with high rigidity can be improved by increasing the servo gains; however, if the servo gains of a machine with low rigidity are increased, the machine can vibrate and the responsivity cannot be improved.

NOTICE
Effectiveness of servo gains
The tuning function only uses the first group of servo gains (position loop gain 1, speed loop gain 1 and speed loop integral time 1).

The following tuning functions are available for the SINAMICS V90 PN servo drive.

Select a tuning mode by setting parameter p29021:

Parameter	Setting value	Description
p29021	0 (default)	Auto tuning is disabled (manual tuning) without changing servo gains relevant parameters.
	1	One-button auto tuning Identify the ratio of load moment of inertia and automatically adjust servo gains accordingly.
	3	Real-time auto tuning Identify the ratio of load moment of inertia and automatically adjust servo gains in real time.
	5	Auto tuning is disabled (manual tuning). All servo gains relevant parameters are set to tuning default values.

Auto-tuning methods

The SINAMICS V90 PN supplies two auto-tuning modes: one-button auto tuning and real-time auto tuning. The auto tuning function can optimize control parameters with ratio of machine load moment of inertia (p29022) and set suitable current filter parameters to suppress the machine resonance automatically. You can change the dynamic performance of the system by setting different dynamic factors.

- One-button auto tuning
 - One-button auto tuning estimates the machine load moment of inertia and mechanical characteristics with internal motion commands. To achieve the desired performance, you can execute the process many times before you control the drive with the host controller. The maximum speed is limited by the rated speed.

- Real-time auto tuning
 - Real-time auto tuning estimates the machine load moment of inertia automatically while the drive is running with the host controller command. After the motor is servo on, the real-time auto tuning function stays effective. If you do not need to estimate the load moment of inertia continuously, you can disable the function when the system performance is acceptable.

You are recommended to save the tuned parameters when the tuning is completed and the drive performance is acceptable.

Tuning with SINAMICS V-ASSISTANT

You are recommended to perform tuning with the engineering tool SINAMICS V-ASSISTANT. For more information, refer to SINAMICS V-ASSISTANT Online Help.

10.3 One-button auto tuning

Note

Before using the one-button auto tuning, move the servo motor to the middle of mechanical position to avoid approaching the actual machine position limit.

Pre-conditions for one-button auto tuning

- The ratio of machine load moment of inertia is still unknown and needs to be estimated.
- The motor is allowed to rotate clockwise and counter clockwise.
- The motor rotation position (p29027 defines that one revolution equals to 360 degree) is allowed by the machine.
 - For the motor with an absolute encoder: position limitation is defined by p29027
 - For the motor with an incremental encoder: the motor must be allowed to rotate freely about two rounds when tuning starts

One-button auto tuning procedure

Proceed as follows to perform one-button auto tuning for the SINAMICS V90 PN servo drive.

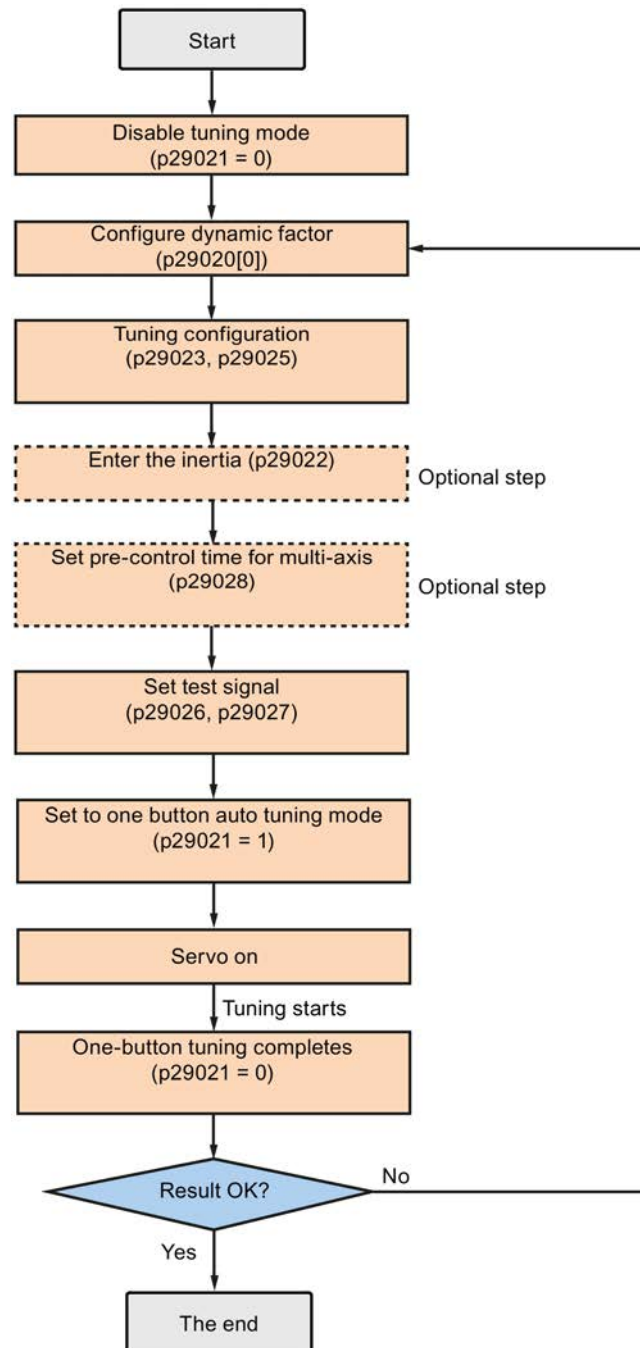

Parameter settings

You can set the ratio of machine load moment of inertia (p29022) with the following methods:

- Enter it manually if you have known the ratio of machine load moment of inertia.
- Estimate the ratio of machine load moment of inertia with one-button auto tuning (p29023.2 = 1). When you have executed the one-button tuning many times and obtained a stable value of p29022, you can stop estimating it by setting p29023.2 = 0.

Parameter	Value range	Default value	Unit	Description
p29020[0...1]	1 to 35	18	-	The dynamic factor of auto tuning <ul style="list-style-type: none"> • [0]: dynamic factor for one-button auto tuning • [1]: dynamic factor for real-time auto tuning
p29021	0 to 5	0	-	Selection of a tuning mode <ul style="list-style-type: none"> • 0: disabled • 1: one-button auto tuning • 3: real-time auto tuning • 5: disabled with default control parameters
p29022	1 to 10000	1	-	Ratio of load moment of inertia
p29023	0 to 0xffff	0x0007	-	One-button auto tuning configuration
p29025	0 to 0x003f	0x0004	-	Overall tuning configuration
p29026	0 to 5000	2000 (default)	ms	Test signal duration
p29027	0 to 30000	0 (default)	°	Limit rotation position of the motor
p29028	0.0 to 60.0	7.5	ms	Pre-control time constant

Parameter p29028 is available when the multi-axis interpolation function is activated (p29023.7 = 1). If the axes are used as the interpolation axes, you need to set the same pre-control time constants (p29028) for them.

You can configure the dynamic factor of the servo system with the parameter p29020. Higher dynamic factor means higher tracking ability and shorter settling time but also higher possibility of resonance. You should find a desired dynamic factor within a resonance-free range.

A total of 35 dynamic factors are available for the SINAMICS V90 PN servo drive:

Dynamic factor (p29020)	Machine rigidity
1	Low
2	↑
...	
17	

Dynamic factor (p29020)	Machine rigidity
18	Middle
19	↓
...	
35	High

If the dynamic factor setting cannot be increased up to the desired level because of machine resonance beyond 250 Hz, the function of resonance suppression can be used to suppress machine resonance and thus increase dynamic factor. Refer to Section "Resonance suppression (Page 241)" for detailed information about the function of resonance suppression.

Note

The tuning configuration parameters must be set carefully when the auto tuning function is disabled (p29021=0).

After servo on, the motor will run with the test signal.

When the one-button auto tuning process completes successfully, the parameter p29021 will be set to 0 automatically. You can also set the parameter p29021 to 0 before servo on to interrupt the one-button tuning process. Before you save the parameters on the drive, make sure that p29021 has changed to 0.

Note

Do not use the JOG function when you use the one-button tuning function.

Note

After the one-button tuning is activated, no operation will be allowed except the servo off and emergency stop.

With one-button auto tuning, the servo drive can automatically estimate the ratio of load moment of inertia and set the following relevant parameters accordingly.

Parameter	Value range	Default value	Unit	Description
p1414	0 to 3	0	-	Speed setpoint filter activation
p1415	0 to 2	0	-	Speed setpoint filter 1 type
p1417	0.5 to 16000	1999	Hz	Speed setpoint filter 1 denominator natural frequency
p1418	0.001 to 10	0.7	-	Speed setpoint filter 1 denominator damping
p1419	0.5 to 16000	1999	Hz	Speed setpoint filter 1 numerator natural frequency
p1420	0.001 to 10	0.7	-	Speed setpoint filter 1 numerator damping
p1441	0 to 50	0	ms	Actual speed smoothing time
p1656	0 to 15	1	-	Activates current setpoint filter
p1658	0.5 to 16000	1999	Hz	Current setpoint filter 1 denominator natural frequency
p1659	0.001 to 10	0.7	-	Current setpoint filter 1 denominator damping
p2533	0 to 1000	0	ms	LR position setpoint filter time constant

Parameter	Value range	Default value	Unit	Description
p2572	1 to 2000000	100	1000 LU/s ²	EPOS maximum acceleration
p2573	1 to 2000000	100	1000 LU/s ²	EPOS maximum deceleration
p29022	1 to 10000	1	-	Ratio of load moment of inertia
p29110	0.00 to 300.00	1.8	1000/min	Position loop gain
p29120	0 to 999999	0.3	Nms/rad	Speed loop gain
p29121	0 to 100000	15	ms	Speed loop integral time
p29111	0 to 200	0	%	Speed pre-control factor (feed forward)

After one-button tuning, four current setpoint filters can be activated at most. The following parameters related to the filters may be tuned accordingly.

Parameter	Value range	Default value	Unit	Description
p1663	0.5 to 16000	1000	Hz	Natural frequency of current notch filter 2 denominator.
p1664	0.001 to 10	0.3	-	Damp of current notch filter 2 denominator.
p1665	0.5 to 16000	1000	Hz	Natural frequency of current notch filter 2 numerator.
p1666	0.0 to 10	0.01	-	Damp of current notch filter 2 numerator.
p1668	0.5 to 16000	1000	Hz	Natural frequency of current notch filter 3 denominator.
p1669	0.001 to 10	0.3	-	Damp of current notch filter 3 denominator.
p1670	0.5 to 16000	1000	Hz	Natural frequency of current notch filter 3 numerator.
p1671	0.0 to 10	0.01	-	Damp of current notch filter 3 numerator.
p1673	0.5 to 16000	1000	Hz	Natural frequency of current notch filter 4 denominator.
p1674	0.001 to 10	0.3	-	Damp of current notch filter 4 denominator.
p1675	0.5 to 16000	1000	Hz-	Natural frequency of current notch filter 4 numerator.
p1676	0.0 to 10	0.01	-	Damp of current notch filter 4 numerator.

Note

After one-button auto tuning is activated, do not change other auto tuning related control/filter parameters since these parameters can be set automatically and your changes will not be accepted.

Note

One-button auto tuning may cause some changes of the control parameters. When the system rigidity is low, this may lead to a situation that when you set EMGS = 0, the motor needs take long time to emergency stop.

10.4 Real-time auto tuning

With real-time auto tuning, the servo drive can automatically estimate the ratio of load moment of inertia and set the optimum control parameters.

Pre-conditions for the real-time auto tuning

- The drive must be controlled by the host controller.
- The machine actual load moment of inertia is different when the machine moves to the different positions.
- Make sure that the motor has multiple accelerations and decelerations. Step command is recommended.
- Machine resonance frequency changes when the machine is running.

Real-time auto tuning procedure

Proceed as follows to perform real-time auto tuning for the SINAMICS V90 PN servo drive.

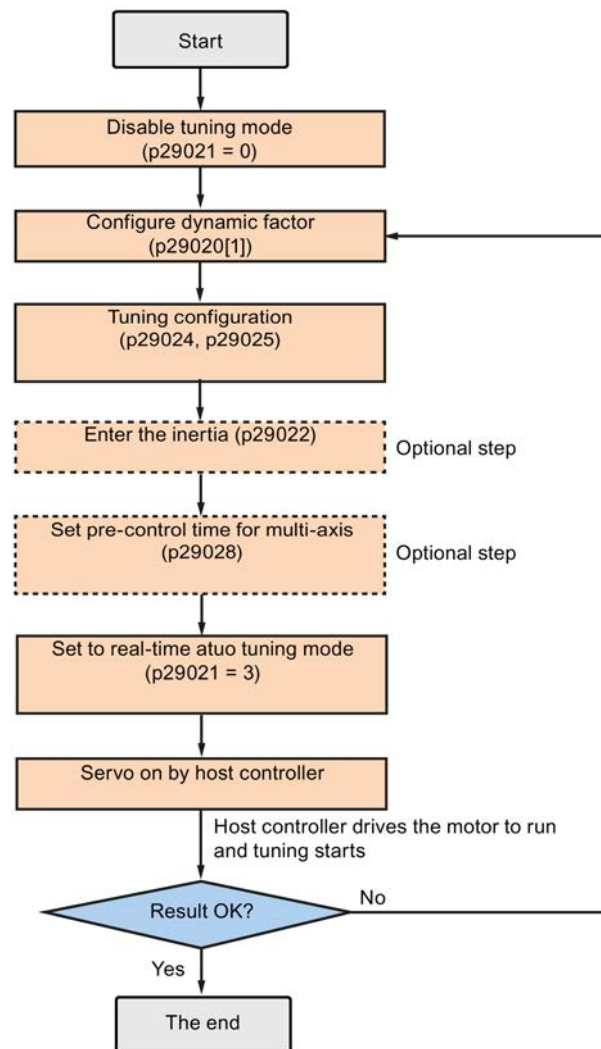

Parameter settings

You can set the ratio of machine load moment of inertia (p29022) with the following methods:

- Enter it manually if you have known the ratio of machine load moment of inertia
- Use the ratio of machine load moment of inertia estimated by the one-button auto tuning function directly
- Estimate the ratio of machine load moment of inertia with real-time auto tuning (p29024.2 = 1). When you have obtained a stable value of p29022, you can stop estimating it by setting p29024.2 = 0.

Parameter	Value range	Default value	Unit	Description
p29020[0...1]	1 to 35	18	-	The dynamic factor of auto tuning. <ul style="list-style-type: none"> • [0]: dynamic factor for one-button auto tuning • [1]: dynamic factor for real-time auto tuning
p29021	0 to 5	0	-	Selection of a tuning mode. <ul style="list-style-type: none"> • 0: disabled • 1: one-button auto tuning • 3: real-time auto tuning • 5: disable with default controller parameters
p29022	1 to 10000	1	-	Ratio of load moment of inertia
p29024	0 to 0xffff	0x004c	-	Real-time auto tuning configuration
p29025	0 to 0x003f	0x0004	-	Overall tuning configuration
p29028	0.0 to 60.0	7.5	ms	Pre-control time constant

Parameter p29028 is available when the multi-axis interpolation function is activated (p29024.7 = 1). If the axes are used as the interpolation axes, you need to set the same pre-control time constants (p29028) for them.

You can configure the dynamic factor of the servo system with the parameter p29020. Higher dynamic factor means higher tracking ability and shorter settling time but also higher possibility of resonance. You should find a desired dynamic factor within a resonance-free range.

35 dynamic factors are available for the SINAMICS V90 PN servo drive:

Dynamic factor (p29020)	Machine rigidity
1	Low
2	↑
...	
17	
18	Middle
19	↓
...	
35	
	High

If the dynamic factor setting cannot be increased up to the desired level because of machine resonance beyond 250 Hz, the function of resonance suppression can be used to suppress machine resonance and thus increase dynamic factor. Refer to Section "Resonance suppression (Page 241)" for detailed information about the function of resonance suppression.

Note

The tuning configuration parameters must be set carefully when the auto tuning function is disabled (p29021=0).

During tuning, you can modify the dynamic factor with p29020[1] to obtain the different dynamic performance after p29022 has been tuned and accepted by the drive.

After servo on, the real-time auto tuning function will always effective for the servo drive. If you want to end or interrupt the real-time auto tuning process, set the drive to the servo off state then set p29021 to 0.

The following relevant parameters can be continuous set in real time when you are using the real-time auto tuning:

Parameter	Value range	Default value	Unit	Description
p1417	0.5 to 16000	1999	Hz	Speed setpoint filter 1 denominator natural frequency
p1419	0.5 to 16000	1999	Hz	Speed setpoint filter 1 numerator natural frequency
p29022	1 to 10000	1	-	Ratio of load moment of inertia
p29110	0.00 to 300.00	1.8	1000/min	Position loop gain
p29120	0 to 999999	0.3	Nms/rad	Speed loop gain
p29121	0 to 100000	15	ms	Speed loop integral time
p29111	0 to 200	0	%	Speed pre-control factor (feed forward)

Note

When using the real-time auto tuning function, if the default values are inappropriate, the host controller cannot run the motor. To run the motor with the host controller, you need to let the drive tune the parameters automatically through trial run with the real-time auto tuning function. After the tuning is completed, the host controller can run the motor.

Note

After the real-time auto tuning is activated, do not change other auto tuning related control/filter parameters since these parameters can be set automatically and your changes will not be accepted.

Note

The real-time auto tuning may not be performed properly if the following conditions are not satisfied:

- Accelerate the motor for 100 ms or more with the acceleration torque.
- The acceleration/deceleration torque is 15% or more of the rated torque.

Under operating conditions that impose sudden disturbance torque during acceleration/deceleration or on a machine that its rigidity is poor, auto tuning may not function properly, either. In such cases, use the one-button auto tuning or manual tuning to optimize the drive.

10.5 Manual tuning

When the auto tuning cannot reach expected tuning results, you can disable the auto tuning function by setting the parameter p29021 and manually perform tuning:

- p29021 = 5: auto tuning function is disabled and all control parameters are reset to tuning default values.
- p29021 = 0: auto tuning function is disabled without changing control parameters.

Procedure for manual tuning

Follow the procedure below to perform manual tuning:

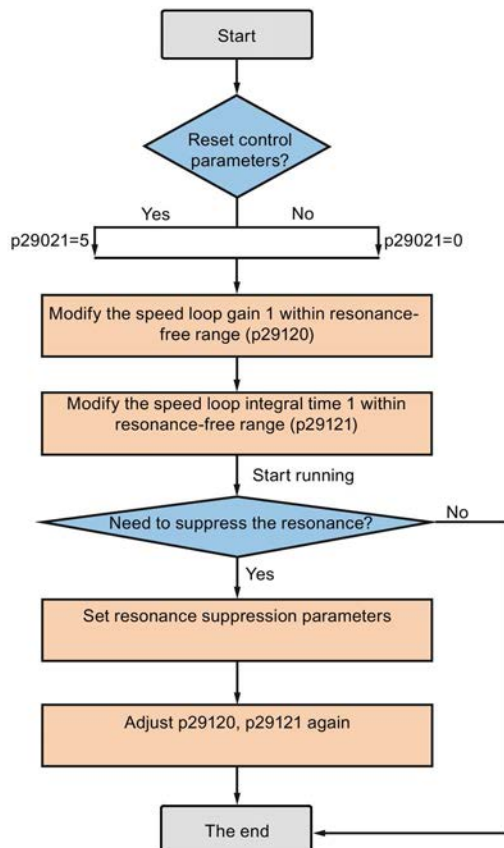

Note

Resonance suppression

For detailed information about the resonance suppression, refer to Section "Resonance suppression (Page 241)".

Parameter settings

You need to set the following servo gains related parameters manually when using the manual tuning function:

Parameter	Value range	Default value	Unit	Description
p2533	0 to 1000	0	ms	LR position setpoint filter time constant
p2572	1 to 2000000	100	1000 LU/s ²	EPOS maximum acceleration
p2573	1 to 2000000	100	1000 LU/s ²	EPOS maximum deceleration
p29110	0.00 to 300.00	1.8	1000 /min	Position loop gain
p29120	0 to 999999	0.3	Nms /rad	Speed loop gain
p29121	0 to 100000	15	ms	Speed loop integral time
p29111	0 to 200	0	%	Speed pre-control factor (feed forward)

10.6 Resonance suppression

The resonance suppression function is filter (notch filter) function. It detects mechanical resonance at a frequency between 250 Hz and 1500 Hz, and decreases the gain of specific frequency (by automatically setting notch filter) to suppress the mechanical resonance.

Now four current setpoint filters are available for the V90 PN servo drive. Filter 1 is lowpass filter. Filter 2, filter 3 and filter 4 are band damp filters.

The gain decreasing frequency, width as well as depth can be set by setting the notch filter:

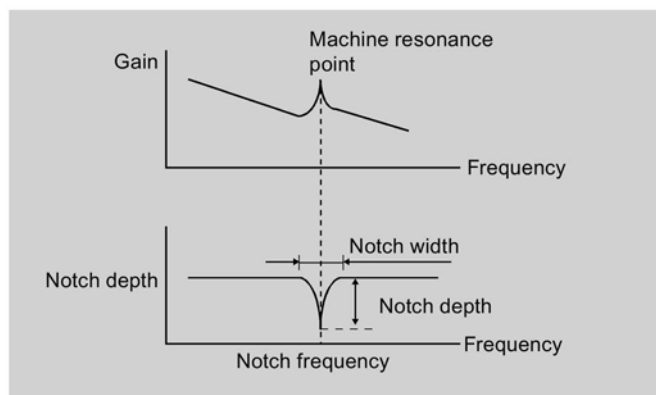

Using the resonance suppression function

Note

The resonance suppression function is used together with the auto tuning function. In real-time auto tuning and one-button auto tuning mode, the function is activated by default.

When you use real-time auto tuning function, you are recommended to disable the resonance suppression function to get a high dynamic performance if there is no resonance in the machine.

The function can be activated/deactivated with the following parameters:

- For one-button auto tuning: bit 1 of p29023
- For real-time auto tuning: bit 6 of p29024

Resonance suppression with one-button auto tuning (p29021=1, p29023.1=1)

Before you use the resonance suppression function with one-button auto tuning, make sure the load is mounted as required and the servo motor can rotate freely. When the one-button auto tuning process completes successfully, the servo drive automatically sets the following notch filter relevant parameters with real machine characteristic. Four current setpoint filters can be activated at most.

Parameter	Value range	Default value	Unit	Description
p1663	0.5 to 16000	1000	Hz	Natural frequency of current notch filter 2 denominator.
p1664	0.001 to 10	0.3	-	Damp of current notch filter 2 denominator.
p1665	0.5 to 16000	1000	Hz	Natural frequency of current notch filter 2 numerator.
p1666	0.0 to 10	0.01	-	Damp of current notch filter 2 numerator.
p1668	0.5 to 16000	1000	Hz	Natural frequency of current notch filter 3 denominator.
p1669	0.001 to 10	0.3	-	Damp of current notch filter 3 denominator.
p1670	0.5 to 16000	1000	Hz	Natural frequency of current notch filter 3 numerator.
p1671	0.0 to 10	0.01	-	Damp of current notch filter 3 numerator.
p1673	0.5 to 16000	1000	Hz	Natural frequency of current notch filter 4 denominator.
p1674	0.001 to 10	0.3	-	Damp of current notch filter 4 denominator.
p1675	0.5 to 16000	1000	Hz-	Natural frequency of current notch filter 4 numerator.
p1676	0.0 to 10	0.01	-	Damp of current notch filter 4 numerator.

Note

Notch filter remains active when the resonance suppression function is activated automatically.

After one-button tuning is completed, four filters can be activated at most. You can deactivate the notch filters by setting the parameter p1656.

Resonance suppression with real-time auto tuning (p29021=3, p29024.6=1)

When you choose to use the resonance suppression function with real-time auto tuning, the servo drive performs real-time detection of the resonance frequency and configures the following notch filter relevant parameters accordingly:

Parameter	Value range	Default value	Unit	Description
p1663	0.5 to 16000	1000	Hz	Natural frequency of current notch filter 2 denominator.
p1664	0.001 to 10	0.3	-	Damp of current notch filter 2 denominator.
p1665	0.5 to 16000	1000	Hz	Natural frequency of current notch filter 2 numerator.
p1666	0.0 to 10	0.01	-	Damp of current notch filter 2 numerator.

Resonance suppression with manual tuning (p29021=0)

When both the resonance suppression with real-time auto tuning and one-button tuning mode cannot reach the suppression effect, you can do the resonance suppression by manually setting the following parameters:

Parameter	Value range	Default value	Unit	Description
p1663	0.5 to 16000	1000	Hz	Natural frequency of current notch filter 2 denominator.
p1664	0.001 to 10	0.3	-	Damp of current notch filter 2 denominator.
p1665	0.5 to 16000	1000	Hz	Natural frequency of current notch filter 2 numerator.
p1666	0.0 to 10	0.01	-	Damp of current notch filter 2 numerator.
p1668	0.5 to 16000	1000	Hz	Natural frequency of current notch filter 3 denominator.
p1669	0.001 to 10	0.3	-	Damp of current notch filter 3 denominator.
p1670	0.5 to 16000	1000	Hz	Natural frequency of current notch filter 3 numerator.
p1671	0.0 to 10	0.01	-	Damp of current notch filter 3 numerator.
p1673	0.5 to 16000	1000	Hz	Natural frequency of current notch filter 4 denominator.
p1674	0.001 to 10	0.3	-	Damp of current notch filter 4 denominator.
p1675	0.5 to 16000	1000	Hz	Natural frequency of current notch filter 4 numerator.
p1676	0.0 to 10	0.01	-	Damp of current notch filter 4 numerator.

Assume the notch frequency is f_{sp} , notch width is f_{BB} , and notch depth is K , then the filter parameters can be calculated as follows:

$$p1663=p1665=f_{sp}$$

$$p1664=f_{BB} / (2 \times f_{sp})$$

$$p1666=(f_{BB} \times 10^{(k/20)}) / (2 \times f_{sp})$$

10.7 Low frequency vibration suppression

The low frequency vibration suppression function is a position setpoint filter function. It can suppress the vibration from 0.5 Hz to 62.5 Hz. The function is available in EPOS control mode.

Related parameters

When you use the vibration suppression function, you need to configure the following parameters accordingly:

Parameter	Value range	Default value	Unit	Description
p29035	0 to 1	0	-	Vibration suppression activation. <ul style="list-style-type: none"> 0: disable 1: enable
p31581	0 to 1	0	-	Vibration suppression filter type. <ul style="list-style-type: none"> 0: filter type rugged 1: filter type sensitive
p31585	0.5 to 62.5	1	Hz	Vibration suppression filter frequency.
p31586	0 to 0.99	0.03	-	Vibration suppression filter damp.

Operating steps

Step	Description	Comment
①	Set the drive to "servo off" state.	
②	Select the filter type by p31581.	Vibration suppression filter type. <ul style="list-style-type: none"> 0: filter type rugged 1: filter type sensitive
③	Set the suppression frequency by p31585.	You can set the suppression frequency from 0.5 Hz to 62.5 Hz.
④	Set the damp of the filter by p31586.	You can set the damp from 0 to 0.99.
⑤	Set the control mode for the drive by p29003.	
⑥	Enable the vibration suppression function by p29035.	Set p29035 = 1 to activate the function.
⑦	Set the drive to "servo on" state.	

Parameters

11.1 Overview

The section below lists all the parameters of the SINAMICS V90 PN servo drive.

Parameter number

Numbers prefixed with an "r" indicate that parameter is a read-only parameter.

Numbers prefixed with a "p" indicate that the parameter is an editable parameter.

Effective

Indicates the conditions for making parameterization effective. Two conditions are possible:

- IM (**I**mmediately): Parameter value becomes effective immediately after changing.
- RE (**R**eset): Parameter value becomes effective after repower-on.

Can be changed

This indicates when the parameter can be changed. Two states are possible:

- U (Run): Can be changed in the "**R**unning" state when the drive is in "servo on" state. The "RDY" LED lights up green.
- T (Ready to run): Can be changed in the "**R**eady" state when the drive is in "servo off" state. The "RDY" LED lights up red.

Note





When judging the state of the drive according to the "RDY" LED, ensure that no faults or alarms exist.

Data type

Date type	Abbreviation	Description
Integer16	I16	16-bit integer
Integer32	I32	32-bit integer
Unsigned8	U8	8-bit unsigned integer
Unsigned16	U16	16-bit unsigned integer
Unsigned32	U32	32-bit unsigned integer
FloatingPoint32	Float	32-bit floating point number

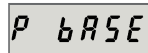
Parameter groups

The SINAMICS V90 PN parameters are divided into the following groups:

Parameter group	Available parameters	Parameter group display on the BOP
Basic parameters	p07xx, p10xx to p16xx, p21xx	
Application parameters	p29xxx	
Communication parameters	p09xx, p89xx	
Basic positioner parameters	p25xx, p26xx	
Status monitoring parameters	All read-only parameters	

11.2 Parameter list

Editable parameters

The values of the parameters marked with an asterisk (*) may be changed after commissioning. Make sure you back up the parameters first as required if you desire to replace the motor. The default values of the parameters marked with two asterisks (**) are motor dependent. They may have different default values when the drive connects to different motors.

Par. No.	Name	Min	Max	Factory Setting	Unit	Data type	Effective	Can be changed
p0748	CU invert digital outputs	-	-	0	-	U32	IM	T, U
	Description: Inverts the signals at the digital outputs. <ul style="list-style-type: none"> • Bit 0: inverts signal DO 1 <ul style="list-style-type: none"> – Bit 0 = 0: not inverted – Bit 0 = 1: inverted • Bit 1: inverts signal DO 2 <ul style="list-style-type: none"> – Bit 1 = 0: not inverted – Bit 1 = 1: inverted 							
p0922	PROFIdrive: PZD telegram selection	1	111	105	-	U16	IM	T
	Description: Sets the send and receive telegram. For speed control mode: <ul style="list-style-type: none"> • 1: Standard telegram 1, PZD-2/2 • 2: Standard telegram 2, PZD-4/4 • 3: Standard telegram 3, PZD-5/9 • 5: Standard telegram 5, PZD-9/9 • 102: SIEMENS telegram 102, PZD-6/10 • 105: SIEMENS telegram 105, PZD-10/10 For basic positioner control mode: <ul style="list-style-type: none"> • 7: Standard telegram 7, PZD-2/2 • 9: Standard telegram 9, PZD-10/5 • 110: SIEMENS telegram 110, PZD-12/7 • 111: SIEMENS telegram 111, PZD-12/12 							
p0925	PROFIdrive: Synchronous sign-of-life tolerance	0	65535	1	-	U16	IM	T, U
	Description: Sets the number of tolerated consecutive sign-of-life errors of the clock-cycle synchronous master. The sign-of-life signal is normally received in PZD4 (control word 2) from the master.							
p0972	Drive unit reset	0	2	0	-	U16	IM	T, U
	Description: Sets the required procedure to execute a hardware reset for the drive unit. <ul style="list-style-type: none"> • 0: Inactive • 1: Hardware reset immediate • 2: Hardware reset preparation 							

11.2 Parameter list

Par. No.	Name	Min	Max	Factory Setting	Unit	Data type	Effective	Can be changed
	<p>Danger: It must be absolutely ensured that the system is in a safe condition. The memory card/device memory of the Control Unit must not be accessed.</p> <p>Note: If value = 1: Reset is immediately executed and communications interrupted. If value = 2: Help to check the reset operation. Firstly, set p0972 = 2 and then read back. Secondly, set p0972 = 1 (it is possible that this request is possibly no longer acknowledged). The communication is then interrupted. After the drive unit has been restarted and communications have been established, read p0972 and check the following: p0972 = 0? → The reset was successfully executed. p0972 > 0? → The reset was not executed.</p>							
p0977	Save all parameters	0	1	0	-	U16	IM	T, U
	<p>Description: Saves all parameters of the drive system to the non-volatile memory. When saving, only the adjustable parameters intended to be saved are taken into account.</p> <ul style="list-style-type: none"> Value = 0: Inactive Value = 1: Save in non-volatile memory - downloaded at POWER ON <p>Notice: The Control Unit power supply may only be powered down after data has been saved (i.e. after data save has been started, wait until the parameter again has the value 0). Writing to parameters is inhibited while saving.</p>							
p1058	JOG 1 speed setpoint	0.00	210000.000	100.00	rpm	Float	IM	T
	<p>Description: Sets the speed/velocity for JOG 1. Jogging is level-triggered and allows the motor to be incrementally moved.</p> <p>Note: The parameter values displayed on the BOP are integers.</p>							
p1082 *	Maximum speed	0.000	210000.000	1500.00 0	rpm	Float	IM	T
	<p>Description: Sets the highest possible speed.</p> <p>Notice: After the value has been modified, no further parameter modifications can be made.</p> <p>Note: The parameter values displayed on the BOP are integers. The parameter applies for both motor directions. The parameter has a limiting effect and is the reference quantity for all ramp-up and ramp-down times (e.g. down ramps, ramp-function generator and motor potentiometer). The range of the parameter is different when connect with different motors.</p>							
p1083 *	Speed limit in positive direction of rotation	0.000	210000.000	210000.000	rpm	Float	IM	T, U
	<p>Description: Sets the maximum speed for the positive direction.</p> <p>Note: The parameter values displayed on the BOP are integers.</p>							
p1086 *	Speed limit in negative direction of rotation	-210000.000	0.000	- 210000.000	rpm	Float	IM	T, U
	<p>Description: Sets the speed limit for the negative direction.</p> <p>Note: The parameter values displayed on the BOP are integers.</p>							

Par. No.	Name	Min	Max	Factory Setting	Unit	Data type	Effective	Can be changed
p1115	Ramp-function generator selection	0	1	0	-	l16	IM	T
	Description: Sets the ramp-function generator type.							
	Note: Another ramp-function generator type can only be selected when the motor is at a standstill.							
p1120	Ramp-function generator ramp-up time	0.000	999999.000	1	s	Float	IM	T, U
	Description: The ramp-function generator ramps-up the speed setpoint from standstill (setpoint = 0) up to the maximum speed (p1082) in this time.							
	Dependency: Refer to p1082							
p1121	Ramp-function generator ramp-down time	0.000	999999.000	1	s	Float	IM	T, U
	Description: Sets the ramp-down time for the ramp-function generator. The ramp-function generator ramps-down the speed setpoint from the maximum speed (p1082) down to standstill (setpoint = 0) in this time. Further, the ramp-down time is always effective for OFF1.							
	Dependency: Refer to p1082							
p1130	Ramp-function generator initial rounding-off time	0.000	30.000	0.000	s	Float	IM	T, U
	Description: Sets the initial rounding-off time for the extended ramp generator. The value applies to ramp-up and ramp-down.							
	Note: Rounding-off times avoid an abrupt response and prevent damage to the mechanical system.							
p1131	Ramp-function generator final rounding-off time	0.000	30.000	0.000	s	Float	IM	T, U
	Description: Sets the final rounding-off time for the extended ramp generator. The value applies to ramp-up and ramp-down.							
	Note: Rounding-off times avoid an abrupt response and prevent damage to the mechanical system.							
p1135	OFF3 ramp-down time	0	600	0	s	Float	IM	T, U
	Description: Sets the ramp-down time from the maximum speed down to zero speed for the OFF3 command.							
	Note: This time can be exceeded if the DC link voltage reaches its maximum value.							
p1215 *	Motor holding brake configuration	0	2	0	-	l16	IM	T
	Description: Sets the holding brake configuration.							
	Dependency: Refer to p1216, p1217, p1226, p1227, p1228							
	Caution: For the setting p1215 = 0, if a brake is used, it remains closed. If the motor moves, this will destroy the brake.							
	Notice: If p1215 was set to 1, then when the pulses are suppressed, the brake is closed even if the motor is still rotating.							
Note: The parameter can only be set to zero when the pulses are inhibited.								
p1216 *	Motor holding brake opening time	0	10000	100	ms	Float	IM	T, U
	Description: Sets the time to open the motor holding brake. After controlling the holding brake (opens), the speed/velocity setpoint remains at zero for this time. After this, the speed/velocity setpoint is enabled.							
	Dependency: Refer to p1215, p1217							
	Note: For a motor with integrated brake, this time is pre-assigned the value saved in the motor. For p1216 = 0 ms, the monitoring and the message A7931 "Brake does not open" are deactivated.							

Par. No.	Name	Min	Max	Factory Setting	Unit	Data type	Effective	Can be changed
p1217 *	Motor holding brake closing time	0	10000	100	ms	Float	IM	T, U
	<p>Description: Sets the time to apply the motor holding brake. After OFF1 or OFF3 and the holding brake is controlled (the brake closes), then the drive remains closed-loop controlled for this time stationary with a speed setpoint/velocity setpoint of zero. The pulses are suppressed when the time expires.</p>							
	<p>Dependency: Refer to p1215, p1216</p>							
	<p>Note: For a motor with integrated brake, this time is pre-assigned the value saved in the motor. For p1217 = 0 ms, the monitoring and the message A07932 "Brake does not close" are deactivated.</p>							
p1226	Threshold for zero speed detection	0.00	210000.00	20.00	rpm	Float	IM	T, U
	<p>Description: Sets the speed threshold for the standstill identification. Acts on the actual value and setpoint monitoring. When braking with OFF1 or OFF3, when the threshold is undershot, standstill is identified. The following applies when the brake control is activated: When the threshold is undershot, the brake control is started and the system waits for the brake closing time in p1217. The pulses are then suppressed. If the brake control is not activated, the following applies: When the threshold is undershot, the pulses are suppressed and the drive coasts down.</p>							
	<p>Dependency: Refer to p1215, p1216, p1217, p1227</p>							
	<p>Notice: For reasons relating to the compatibility to earlier firmware versions, a parameter value of zero in indices 1 to 31 is overwritten with the parameter value in index 0 when the drive boots.</p>							
	<p>Note: Standstill is identified in the following cases: - The speed actual value falls below the speed threshold in p1226 and the time started after this in p1228 has expired. - The speed setpoint falls below the speed threshold in p1226 and the time started after this in p1227 has expired. The actual value sensing is subject to measuring noise. For this reason, standstill cannot be detected if the speed threshold is too low.</p>							
	<p>Dependency: Refer to p1215, p1216, p1217, p1226</p>							
p1227	Zero speed detection monitoring time	0.000	300.000	300.000	s	Float	IM	T, U
	<p>Description: Sets the monitoring time for the standstill identification. When braking with OFF1 or OFF3, standstill is identified after this time has expired, after the setpoint speed has fallen below p1226. After this, the brake control is started, the system waits for the closing time in p1217 and then the pulses are suppressed.</p>							
	<p>Dependency: Refer to p1215, p1216, p1217, p1226</p>							
	<p>Notice: The setpoint is not equal to zero dependent on the selected value. This can therefore cause the monitoring time in p1227 to be exceeded. In this case, for a driven motor, the pulses are not suppressed..</p>							

Par. No.	Name	Min	Max	Factory Setting	Unit	Data type	Effective	Can be changed
	<p>Note: Standstill is identified in the following cases:</p> <ul style="list-style-type: none"> - The speed actual value falls below the speed threshold in p1226 and the time started after this in p1228 has expired. - The speed setpoint falls below the speed threshold in p1226 and the time started after this in p1227 has expired. <p>For p1227 = 300.000 s, the following applies: Monitoring is de-activated.</p> <p>For p1227 = 0.000 s, the following applies: With OFF1 or OFF3 and a ramp-down time = 0, the pulses are immediately suppressed and the motor "coasts" down.</p>							
p1228	Pulse suppression delay time	0.000	299.000	0.000	s	Float	IM	T, U
	<p>Description: Sets the delay time for pulse suppression. After OFF1 or OFF3, the pulses are canceled, if at least one of the following conditions is fulfilled:</p> <ul style="list-style-type: none"> - The speed actual value falls below the threshold in p1226 and the time started after this in p1228 has expired. - The speed setpoint falls below the threshold in p1226 and the time started after this in p1227 has expired. <p>Dependency: Refer to p1226, p1227</p> <p>Notice: When the motor holding brake is activated, pulse cancellation is additionally delayed by the brake closing time (p1217).</p>							
p1414	Speed setpoint filter activation	-	-	0000 bin	-	U16	IM	T, U
	<p>Description: Setting for activating/de-activating the speed setpoint filter.</p> <ul style="list-style-type: none"> • Bit 0: Activate filter 1 <ul style="list-style-type: none"> - Bit 0 = 0: Deactivated - Bit 0 = 1: Activated • Bit 1: Activate filter 2 <ul style="list-style-type: none"> - Bit 1 = 0: Deactivated - Bit 1 = 1: Activated <p>Dependency: The individual speed setpoint filters are parameterized as of p1415.</p> <p>Note: The drive unit displays the value in hex format. To know the logic (high/low) assignment to each bit, you must convert the hex number to the binary number, for example, FF (hex) = 11111111 (bin).</p>							
p1415	Speed setpoint filter 1 type	0	2	0	-	l16	IM	T, U
	<p>Description: Sets the type for speed setpoint filter 1.</p> <p>Dependency: PT1 low pass: p1416 PT2 low pass: p1417, p1418 General filter: p1417 ... p1420</p>							
p1416	Speed setpoint filter 1 time constant	0.00	5000.00	0.00	ms	Float	IM	T, U
	<p>Description: Sets the time constant for the speed setpoint filter 1 (PT1).</p> <p>Dependency: Refer to p1414, p1415</p> <p>Note: This parameter is only effective if the filter is set as a PT1 low pass.</p>							

11.2 Parameter list

Par. No.	Name	Min	Max	Factory Setting	Unit	Data type	Effective	Can be changed
p1417	Speed setpoint filter 1 denominator natural frequency	0.5	16000.0	1999.0	Hz	Float	IM	T, U
	Description: Sets the denominator natural frequency for speed setpoint filter 1(PT2, general filter).							
	Dependency: Refer to p1414, p1415							
	Note: This parameter is only effective if the speed filter is parameterized as a PT2 low pass or as general filter. The filter is only effective if the natural frequency is less than half of the sampling frequency.							
p1418	Speed setpoint filter 1 denominator damping	0.001	10.000	0.700	-	Float	IM	T, U
	Description: Sets the denominator damping for speed setpoint filter 1 (PT2, general filter).							
	Dependency: Refer to p1414, p1415							
	Note: This parameter is only effective if the speed filter is parameterized as a PT2 low pass or as general filter.							
p1419	Speed setpoint filter 1 numerator natural frequency	0.5	16000.0	1999.0	Hz	Float	IM	T, U
	Description: Sets the numerator natural frequency for speed setpoint filter 1 (general filter).							
	Dependency: Refer to p1414, p1415							
	Note: This parameter is only effective if the speed filter is set as a general filter. The filter is only effective if the natural frequency is less than half of the sampling frequency.							
p1420	Speed setpoint filter 1 numerator damping	0.001	10.000	0.700	-	Float	IM	T, U
	Description: Sets the numerator damping for speed setpoint filter 1 (general filter).							
	Dependency: Refer to p1414, p1415							
	Note: This parameter is only effective if the speed filter is set as a general filter.							
p1421	Speed setpoint filter 2 type	0	2	0	-	I16	IM	T, U
	Description: Sets the type for speed setpoint filter 2.							
	Dependency: PT1 low pass: p1422 PT2 low pass: p1423, p1424 General filter: p1423 ... p1426							
p1422	Speed setpoint filter 2 time constant	0.00	5000.00	0.00	ms	Float	IM	T, U
	Description: Sets the time constant for the speed setpoint filter 2 (PT1).							
	Dependency: Refer to p1414, p1421							
	Note: This parameter is only effective if the speed filter is set as a PT1 low pass.							
p1423	Speed setpoint filter 2 denominator natural frequency	0.5	16000.0	1999.0	Hz	Float	IM	T, U
	Description: Sets the denominator natural frequency for speed setpoint filter 2 (PT2, general filter).							
	Dependency: Refer to p1414, p1421							

Par. No.	Name	Min	Max	Factory Setting	Unit	Data type	Effective	Can be changed
	<p>Note: This parameter is only effective if the speed filter is parameterized as a PT2 low pass or as general filter. The filter is only effective if the natural frequency is less than half of the sampling frequency.</p>							
p1424	Speed setpoint filter 2 denominator damping	0.001	10.000	0.700	-	Float	IM	T, U
	<p>Description: Sets the denominator damping for speed setpoint filter 2 (PT2, general filter).</p>							
	<p>Dependency: Refer to p1414, p1421</p>							
	<p>Note: This parameter is only effective if the speed filter is parameterized as a PT2 low pass or as general filter.</p>							
p1425	Speed setpoint filter 2 numerator natural frequency	0.5	16000.0	1999.0	Hz	Float	IM	T, U
	<p>Description: Sets the numerator natural frequency for speed setpoint filter 2 (general filter).</p>							
	<p>Dependency: Refer to p1414, p1421</p>							
	<p>Note: This parameter is only effective if the speed filter is set as a general filter. The filter is only effective if the natural frequency is less than half of the sampling frequency.</p>							
p1426	Speed setpoint filter 2 numerator damping	0.000	10.000	0.700	-	Float	IM	T, U
	<p>Description: Sets the numerator damping for speed setpoint filter 2 (general filter).</p>							
	<p>Dependency: Refer to p1414, p1421</p>							
	<p>Note: This parameter is only effective if the speed filter is set as a general filter.</p>							
p1441	Actual speed smoothing time	0.00	50.00	0.00	ms	Float	IM	T, U
	<p>Description: Sets the smoothing time constant (PT1) for the speed actual value.</p>							
	<p>Note: The speed actual value should be smoothed for increment encoders with a low pulse number. After this parameter has been changed, we recommend that the speed controller is adapted and/or the speed controller settings checked Kp (p29120) and Tn (p29121).</p>							
p1520 *	Torque limit upper	-1000000.00	2000000.00	0.00	Nm	Float	IM	T, U
	<p>Description: Sets the fixed upper torque limit.</p>							
	<p>Danger: Negative values when setting the upper torque limit (p1520 < 0) can result in the motor accelerating in an uncontrollable fashion.</p>							
	<p>Notice: The maximum value depends on the maximum torque of the connected motor.</p>							
p1521 *	Torque limit lower	-2000000.00	1000000.00	0.00	Nm	Float	IM	T, U
	<p>Description: Sets the fixed lower torque limit.</p>							
	<p>Danger: Positive values when setting the lower torque limit (p1521 > 0) can result in the motor accelerating in an uncontrollable fashion.</p>							
	<p>Notice: The maximum value depends on the maximum torque of the connected motor.</p>							

Par. No.	Name	Min	Max	Factory Setting	Unit	Data type	Effective	Can be changed
p1656 *	Activates current setpoint filter	-	-	0001 bin	-	U16	IM	T, U
<p>Description: Setting for activating/de-activating the current setpoint filter.</p> <ul style="list-style-type: none"> • Bit 0: Activate filter 1 <ul style="list-style-type: none"> – Bit 0 = 0: Deactivated – Bit 0 = 1: Activated • Bit 1: Activate filter 2 <ul style="list-style-type: none"> – Bit 1 = 0: Deactivated – Bit 1 = 1: Activated • Bit 2: Activate filter 3 <ul style="list-style-type: none"> – Bit 2 = 0: Deactivated – Bit 2 = 1: Activated • Bit 3: Activate filter 4 <ul style="list-style-type: none"> – Bit 3 = 0: Deactivated – Bit 3 = 1: Activated 								
<p>Dependency: The individual current setpoint filters are parameterized as of p1658.</p>								
<p>Note: If not all of the filters are required, then the filters should be used consecutively starting from filter 1. The drive unit displays the value in hex format. To know the logic (high/low) assignment to each bit, you must convert the hex number to the binary number, for example, FF (hex) = 11111111 (bin).</p>								
p1658 *	Current setpoint filter 1 denominator natural frequency	0.5	16000.0	1999.0	Hz	Float	IM	T, U
<p>Description: Sets the denominator natural frequency for current setpoint filter 1 (PT2, general filter).</p>								
<p>Dependency: The current setpoint filter 1 is activated via p1656.0 and parameterized via p1658 ... p1659.</p>								
p1659 *	Current setpoint filter 1 denominator damping	0.001	10.000	0.700	-	Float	IM	T, U
<p>Description: Sets the denominator damping for current setpoint filter 1.</p>								
<p>Dependency: The current setpoint filter 1 is activated via p1656.0 and parameterized via p1658 ... p1659.</p>								
p1663	Current setpoint filter 2 denominator natural frequency	0.5	16000.0	1000.0	Hz	Float	IM	T, U
<p>Description: Sets the denominator natural frequency for current setpoint filter 2 (PT2, general filter).</p>								
<p>Dependency: Current setpoint filter 2 is activated via p1656.1 and parameterized via p1663 ... p1666.</p>								
p1664	Current setpoint filter 2 denominator damping	0.001	10.000	0.300	-	Float	IM	T, U
<p>Description: Sets the denominator damping for current setpoint filter 2.</p>								
<p>Dependency: Current setpoint filter 2 is activated via p1656.1 and parameterized via p1663 ... p1666.</p>								
p1665	Current setpoint filter 2 numerator natural frequency	0.5	16000.0	1000.0	Hz	Float	IM	T, U
<p>Description: Sets the numerator natural frequency for current setpoint filter 2 (general filter).</p>								
<p>Dependency: Current setpoint filter 2 is activated via p1656.1 and parameterized via p1662 ... p1666.</p>								

Par. No.	Name	Min	Max	Factory Setting	Unit	Data type	Effective	Can be changed
p1666	Current setpoint filter 2 numerator damping	0.000	10.000	0.010	-	Float	IM	T, U
	Description: Sets the numerator damping for current setpoint filter 2.							
	Dependency: Current setpoint filter 2 is activated via p1656.1 and parameterized via p1663 ... p1666.							
p1668	Current setpoint filter 3 denominator natural frequency	0.5	16000.0	1000.0	Hz	Float	IM	T, U
	Description: Sets the denominator natural frequency for current setpoint filter 3 (PT2, general filter).							
	Dependency: Current setpoint filter 3 is activated via p1656.2 and parameterized via p1668 ... p1671.							
p1669	Current setpoint filter 3 denominator damping	0.001	10.000	0.300	-	Float	IM	T, U
	Description: Sets the denominator damping for current setpoint filter 3.							
	Dependency: Current setpoint filter 3 is activated via p1656.2 and parameterized via p1668 ... p1671.							
p1670	Current setpoint filter 3 numerator natural frequency	0.5	16000.0	1000.0	Hz	Float	IM	T, U
	Description: Sets the numerator natural frequency for current setpoint filter 3 (general filter).							
	Dependency: Current setpoint filter 3 is activated via p1656.2 and parameterized via p1668 ... p1671.							
p1671	Current setpoint filter 3 numerator damping	0.000	10.000	0.010	-	Float	IM	T, U
	Description: Sets the numerator damping for current setpoint filter 3.							
	Dependency: Current setpoint filter 3 is activated via p1656.2 and parameterized via p1668 ... p1671.							
p1673	Current setpoint filter 4 denominator natural frequency	0.5	16000.0	1000.0	Hz	Float	IM	T, U
	Description: Sets the denominator natural frequency for current setpoint filter 4 (PT2, general filter).							
	Dependency: Current setpoint filter 4 is activated via p1656.3 and parameterized via p1673 ... p1675.							
p1674	Current setpoint filter 4 denominator damping	0.001	10.000	0.300	-	Float	IM	T, U
	Description: Sets the denominator damping for current setpoint filter 4.							
	Dependency: Current setpoint filter 4 is activated via p1656.3 and parameterized via p1673 ... p1675.							
p1675	Current setpoint filter 4 numerator natural frequency	0.5	16000.0	1000.0	Hz	Float	IM	T, U
	Description: Sets the numerator natural frequency for current setpoint filter 4 (general filter).							
	Dependency: Current setpoint filter 4 is activated via p1656.3 and parameterized via p1673 ... p1675.							
p1676	Current setpoint filter 4 numerator damping	0.000	10.000	0.010	-	Float	IM	T, U
	Description: Sets the numerator damping for current setpoint filter 4.							
	Dependency: Current setpoint filter 4 is activated via p1656.3 and parameterized via p1673 ... p1675.							
p2000	Reference speed	6.00	210000.00	3000.00	rpm	Float	IM	T
	Description: Sets the reference quantity for speed and frequency. All speeds or frequencies specified as relative value are referred to this reference quantity. The reference quantity corresponds to 100% or 4000 hex (word) or 40000000 hex (double word).							
	Dependency: Refer to: p2003							

11.2 Parameter list

Par. No.	Name	Min	Max	Factory Setting	Unit	Data type	Effective	Can be changed
p2002	Reference current	0.10	100000.00	100.00	Arms	Float	IM	T
<p>Description: Sets the reference quantity for currents. All currents specified as relative value are referred to this reference quantity. The reference quantity corresponds to 100% or 4000 hex (word) or 4000 0000 hex (double word).</p> <p>Notice: If various DDS are used with different motor data, then the reference quantities remain the same as these are not changed over with the DDS. The resulting conversion factor should be taken into account (e.g. for trace records). Example: p2002 = 100 A Reference quantity 100 A corresponds to 100 %</p>								
p2003	Reference torque	0.01	20000000.00	1.00	Nm	Float	IM	T
<p>Description: Sets the reference quantity for torque. All torques specified as relative value are referred to this reference quantity. The reference quantity corresponds to 100% or 4000 hex (word) or 40000000 hex (double word).</p>								
p2118[0...19]	Message number selection of a type-to-be-changed message	0	65535	[0] 6310 [1] 7594 [2] 7566 [3] 32905 [4...19] 0	-	U16	IM	T, U
<p>Description: Selects faults or alarms of whose message type should be changed.</p> <p>Dependency: Selects the fault or alarm and sets the required type of message realized under the same index. Refer to: p2119</p> <p>Note: Re-parameterization is also possible if a message is present. The change only becomes effective after the message has gone.</p>								
p2119[0...19]	Change the type for a message	1	3	[0] 2 [1...3] 3 [4...19] 1	-	I16	IM	T, U
<p>Description: Sets the message type for the selected fault or alarm.</p> <ul style="list-style-type: none"> Value = 1: Fault (F) Value = 2: Alarm (A) Value = 3: No message (N) <p>Dependency: Selects the fault or alarm and sets the required type of message realized under the same index. Refer to: p2118</p> <p>Note: Re-parameterization is also possible if a message is present. The change only becomes effective after the message has gone. The message type can only be changed for messages with the appropriate identification (exception, value = 0). Example: F12345(A): Fault F12345 can be changed to alarm A12345.</p>								

Par. No.	Name	Min	Max	Factory Setting	Unit	Data type	Effective	Can be changed
p2153	Speed actual value filter time constant	0	1000000	0	ms	Float	IM	T, U
	Description: Sets the time constant of the PT1 element to smooth the speed/velocity actual value. The smoothed actual speed/velocity is compared with the threshold values and is only used for messages and signals.							
p2161 *	Speed threshold 3	0.00	210000.00	10.00	rpm	Float	IM	T, U
	Description: Sets the speed threshold value for the signal that indicates the axis is stationary.							
p2162 *	Hysteresis speed n_act > n_max	0.00	60000.00	0.00	rpm	Float	IM	T, U
	Description: Sets the hysteresis speed (bandwidth) for the signal "n_act > n_max".							
	Note: For a negative speed limit, the hysteresis is effective below the limit value and for a positive speed limit above the limit value. If significant overshoot occurs in the maximum speed range (for example, due to load shedding), you are advised to increase the dynamic response of the speed controller (if possible). If this is insufficient, the hysteresis p2162 can be increased, but its value must not be greater than the value calculated by the formula below when the motor maximum speed is sufficiently greater than the maximum speed p1082. $p2162 \leq 1.05 \times \text{motor maximum speed} - \text{maximum speed (p1082)}$ The range of the parameter is different when connect with different motors.							
p2175 *	Motor blocked speed threshold	0.00	210000.00	210000.00	rpm	Float	IM	T, U
	Description: Sets the speed threshold for the message "Motor blocked". Dependency: Refer to p2177.							
p2177 *	Motor blocked delay time	0.000	65.000	0.500	s	Float	IM	T, U
	Description: Sets the delay time for the message "Motor blocked". Dependency: Refer to p2175.							
p2525	LR encoder adjustment offset	0	4294967295	0	LU	U32	IM	T
	Description: Position offset when adjusting the absolute encoder. Note: The position offset is only relevant for absolute encoders. The drive determines the value when adjusting the absolute encoder and the user should not change it.							
p2533	LR position setpoint filter time constant	0.00	1000.00	0.00	ms	Float	IM	T, U
	Description: Sets the time constant for the position setpoint filter (PT1).							
	Note: The effective Kv factor (position loop gain) is reduced with the filter. This allows a softer control behavior with improved tolerance with respect to noise/disturbances. Applications: - Reduces the pre-control dynamic response. - Jerk limiting.							
p2542 *	LR standstill window	0	2147483647	1000	LU	U32	IM	T, U
	Description: Sets the standstill window for the standstill monitoring function. After the standstill monitoring time expires, it is cyclically checked whether the difference between the setpoint and actual position is located within the standstill window and, if required, an appropriate fault is output. Value = 0: The standstill monitoring is deactivated.							

11.2 Parameter list

Par. No.	Name	Min	Max	Factory Setting	Unit	Data type	Effective	Can be changed
	Dependency: Refer to: p2543, p2544, and F07450							
	Note: The following applies for the setting of the standstill and positioning window: Standstill window (p2542) ≥ positioning window (p2544)							
p2543 *	LR standstill monitoring time	0.00	100000.00	200.00	ms	Float	IM	T, U
	Description: Sets the standstill monitoring time for the standstill monitoring function. After the standstill monitoring time expires, it is cyclically checked whether the difference between the setpoint and actual position is located within the standstill window and, if required, an appropriate fault is output.							
	Dependency: Refer to: p2542, p2545, and F07450							
	Note: The following applies for the setting of the standstill and positioning monitoring time: Standstill monitoring time (p2543) ≤ positioning monitoring time (p2545)							
p2544 *	LR positioning window	0	214748364 7	40	LU	U32	IM	T, U
	Description: Sets the positioning window for the positioning monitoring function. After the positioning monitoring time expires, it is checked once as to whether the difference between the setpoint and actual position lies within the positioning window and if required an appropriate fault is output. Value = 0: The positioning monitoring function is de-activated.							
	Dependency: Refer to: p2542, p2545, and F07451							
	Note: The following applies for the setting of the standstill and positioning window: Standstill window (p2542) ≥ positioning window (p2544)							
p2545 *	LR positioning monitoring time	0.00	100000.00	1000.00	ms	Float	IM	T, U
	Description: Sets the positioning monitoring time for the positioning monitoring. After the positioning monitoring time expires, it is checked once as to whether the difference between the setpoint and actual position lies within the positioning window and if required an appropriate fault is output.							
	Dependency: The range of p2545 depends on p2543. Refer to: p2543, p2544, and F07451							
	Note: The following applies for the setting of the standstill and positioning monitoring time: Standstill monitoring time (p2543) ≤ positioning monitoring time (p2545)							
p2546 *	LR dynamic following error monitoring tolerance	0	214748364 7	3000	LU	U32	IM	T, U
	Description: Sets the tolerance for the dynamic following error monitoring. If the dynamic following error (r2563) exceeds the selected tolerance, then an appropriate fault is output. Value = 0: The dynamic following error monitoring is deactivated.							
	Dependency: Refer to: r2563, F07452							
	Note: The tolerance bandwidth is intended to prevent the dynamic following error monitoring incorrectly responding due to operational control sequences (e.g. during load surges).							
p2571	IPos maximum velocity	1	40000000	30000	100 0 LU/ min	U32	IM	T, U
	Description: Sets the maximum velocity for the "basic positioner" function (EPOS).							
	Note: The maximum velocity is active in all of the operating modes of the basic positioner. The maximum velocity for the basic positioner should be aligned with the maximum speed/velocity of the speed/velocity controller: $p2571[1000 \text{ LU/min}] = \max_speed[\text{rpm}] \times p29248/p29249 \times p29247/1000$							

Par. No.	Name	Min	Max	Factory Setting	Unit	Data type	Effective	Can be changed
p2572 **	EPOS maximum acceleration	1	2000000	100	100 0 LU/s ²	U32	IM	T
Description: Sets the maximum acceleration for the "basic positioner" function (EPOS).								
Dependency: Refer to: p2619								
Note: The maximum acceleration appears to exhibit jumps (without jerk). "Traversing blocks" operating mode: The programmed acceleration override (p2619) acts on the maximum acceleration. "Direct setpoint input/MDI" mode: The acceleration override is effective (p2644, 4000 hex = 100%). "Jog" and "search for reference" modes: No acceleration override is active. The axis starts with the maximum acceleration.								
p2573 **	EPOS maximum deceleration	1	2000000	100	100 0 LU/s ²	U32	IM	T
Description: Sets the maximum deceleration for the "basic positioner" function (EPOS).								
Dependency: Refer to: p2620								
Note: The maximum deceleration appears to exhibit jumps (without jerk). "Traversing blocks" operating mode: The programmed deceleration override (p2620) acts on the maximum deceleration. "Direct setpoint input/MDI" mode: The deceleration override is effective (p2645, 4000 hex = 100%). "Jog" and "search for reference" modes: No deceleration override is effective. The axis brakes with the maximum deceleration.								
p2574 **	EPOS jerk limiting	1	100000000	200000 0	100 0 LU/s ³	U32	IM	T, U
Description: Sets the jerk limiting.								
Dependency: Refer to p2572, p2573, and p2575								
Note: The jerk limiting is internally converted into a jerk time as follows: Jerk time $T_r = \max(p2572, p2573)/p2574$								
p2575	EPOS jerk limiting activation	0	1	0	-	U32	IM	T
Description: Activates the jerk limiting. • 0: The jerk limiting is deactivated. • 1: The jerk limiting is activated.								
Dependency: Refer to p2574								
p2580	EPOS software limit switch minus	-2147482648	2147482647	- 214748 2648	LU	I32	IM	T, U
Description: Sets the software limit switch in the negative direction of travel.								
Dependency: Refer to p2581, p2582								

11.2 Parameter list

Par. No.	Name	Min	Max	Factory Setting	Unit	Data type	Effective	Can be changed
p2581	EPOS software limit switch plus	-2147482648	2147482647	2147482647	LU	I32	IM	T, U
	Description: Sets the software limit switch in the positive direction of travel.							
	Dependency: Refer to p2580, p2582							
p2582	EPOS software limit switch activation	-	-	0	-	U32/Binary	IM	T
	Description: Sets the signal source to activate the "software limit switch".							
	Dependency: Refer to p2580, p2581							
	Caution: Software limit switch effective: - Axis is referenced. Software limit switch ineffective: - Modulo correction active. - Search for reference is executed.							
	Notice: Target position for relative positioning outside software limit switch: The traversing block is started and the axis comes to a standstill at the software limit switch. An appropriate alarm is output and the traversing block is interrupted. Traversing blocks with valid position can be activated. Target position for absolute positioning outside software limit switch: In the "traversing blocks" mode, the traversing block is not started and an appropriate fault is output. Axis outside the valid traversing range: If the axis is already outside the valid traversing range, then an appropriate fault is output. The fault can be acknowledged at standstill. Traversing blocks with valid position can be activated.							
	Note: The traversing range can also be limited using STOP cams.							
p2583	EPOS backlash compensation	-200000	200000	0	LU	I32	IM	T, U
	Description: Sets the amount of play (backlash) for positive or negative play. <ul style="list-style-type: none"> • = 0: The backlash compensation is deactivated. • > 0: Positive backlash (normal case) When the direction is reversed, the encoder actual value leads the actual value. • < 0: Negative backlash When the direction is reversed, the actual value leads the encoder actual value. 							
	Dependency: If a stationary axis is referenced by setting the reference point, or an adjusted with absolute encoder is powered up, then the setting of p2604 is relevant for entering the compensation value. p2604 = 1: Traveling in the positive direction -> A compensation value is immediately entered. Traveling in the negative direction -> A compensation value is not entered p2604 = 0: Traveling in the positive direction -> A compensation value is not entered Traveling in the negative direction -> A compensation value is immediately entered. When again setting the reference point (a referenced axis) or for "flying referencing", p2604 is not relevant but instead the history of the axis. Refer to: p2604							

Par. No.	Name	Min	Max	Factory Setting	Unit	Data type	Effective	Can be changed
p2585	EPOS jog 1 setpoint velocity	-40000000	40000000	-300	100 0 L U/mi n	I32	IM	T, U
	Description: Sets the setpoint speed for jog 1.							
	Dependency: Refer to: p2587							
p2586	EPOS jog 2 setpoint velocity	-40000000	40000000	300	100 0 L U/mi n	I32	IM	T, U
	Description: Sets the setpoint speed for jog 2.							
	Dependency: Refer to: p2588							
p2587	EPOS jog 1 traversing distance	0	214748264 7	1000	LU	U32	IM	T, U
	Description: Sets the traversing distance for incremental jog 1.							
	Dependency: Refer to: p2585							
p2588	EPOS jog 2 traversing distance	0	214748264 7	1000	LU	U32	IM	T, U
	Description: Sets the traversing distance for incremental jog 2.							
	Dependency: Refer to: p2586							
p2599	EPOS reference point coordinate value	-2147482648	214748264 7	0	LU	I32	IM	T, U
	Description: Sets the position value for the reference point coordinate. This value is set as the actual axis position after referencing or adjustment.							
	Dependency: Refer to: p2525							
p2600	EPOS search for reference point offset	-2147482648	214748264 7	0	LU	I32	IM	T, U
	Description: Sets the reference point offset for search for reference.							
p2604	EPOS search for reference start direction	-	-	0	-	U32/Binary	IM	T
	Description: Sets the signal sources for the start direction of the search for reference.							
	<ul style="list-style-type: none"> • 1 signal: Start in the negative direction. • 0 signal: Start in the positive direction. 							
Dependency: Refer to p2583								
p2605	EPOS search for reference approach velocity reference cam	1	40000000	5000	100 0 L U/mi n	U32	IM	T, U
	Description: Sets the approach velocity to the reference cam for the search for reference.							
	Dependency: The search for reference only starts with the approach velocity to the reference cam when there is a reference cam. Refer to: p2604, p2606							
	Note: When traversing to the reference cam, the velocity override is effective. If, at the start of the search for reference, the axis is already at the reference cam, then the axis immediately starts to traverse to the zero mark.							

11.2 Parameter list

Par. No.	Name	Min	Max	Factory Setting	Unit	Data type	Effective	Can be changed
p2606	EPOS search for reference reference cam maximum distance	0	2147482647	2147482647	LU	U32	IM	T, U
	Description: Sets the maximum distance after the start of the search for reference when traversing to the reference cam.							
	Dependency: Refer to: p2604, p2605, and F07458							
	Note: When using a reversing cam, the maximum distance must be set appropriately long.							
p2608	EPOS search for reference approach velocity zero mark	1	40000000	300	100 0 L U/mi n	U32	IM	T, U
	Description: Sets the approach velocity after detecting the reference cam to search for the zero mark for the search for reference.							
	Dependency: If there is no reference cam, the search for reference immediately starts with the axis traversing to the zero mark. Refer to: p2604, p2609							
	Caution: If the reference cam is not adjusted so that at each search for reference the same zero mark for synchronization is detected, then an "incorrect" axis reference point is obtained. After the reference cam has been left, the search for the zero mark is activated with a time delay due to internal factors. This is the reason that the reference cam should be adjusted in this center between two zero marks and the approach velocity should be adapted to the distance between two zero marks.							
	Note: The velocity override is not effective when traversing to the zero mark.							
p2609	EPOS search for reference max. distance ref. cam and zero mark	0	2147482647	20000	LU	U32	IM	T, U
	Description: Sets the maximum distance after leaving the reference cam when traversing to the zero mark.							
	Dependency: Refer to: p2604, p2608, and F07459							
p2611	EPOS search for reference approach velocity reference point	1	40000000	300	100 0 L U/mi n	U32	IM	T, U
	Description: Sets the approach velocity after detecting the zero mark to approach the reference point.							
	Dependency: Refer to: p2604, p2609							
	Note: When traversing to the reference point, the velocity override is not effective.							
p2617[0... 15]	EPOS traversing block position	-2147482648	2147482647	0	LU	I32	IM	T, U
	Description: Sets the target position for the traversing block.							
	Dependency: Refer to: p2618, p2619, p2620, p2621, p2622, p2623							
	Note: The target position is approached in either relative or absolute terms depending on p2623.							
p2618[0... 15]	EPOS traversing block velocity	1	40000000	600	100 0 L U/mi n	I32	IM	T, U
	Description: Sets the velocity for the traversing block.							
	Dependency: Refer to: p2617, p2619, p2620, p2621, p2622, p2623							
	Note: The velocity can be influenced using the velocity override.							

Par. No.	Name	Min	Max	Factory Setting	Unit	Data type	Effective	Can be changed
p2619[0...15]	EPOS traversing block acceleration override	1.0	100.0	100.0	%	Float	IM	T, U
	Description: Sets the acceleration override for the traversing block. The override refers to the maximum acceleration (p2572).							
	Dependency: Refer to: p2572, p2617, p2618, p2620, p2621, p2622, p2623							
p2620[0...15]	EPOS traversing deceleration override	1.0	100.0	100.0	%	Float	IM	T, U
	Description: Sets the deceleration override for the traversing block. The override refers to the maximum deceleration (p2573).							
	Dependency: Refer to: p2573, p2617, p2618, p2619, p2621, p2622, p2623							
p2621[0...15]	EPOS traversing block task	1	9	1	%	-	IM	T, U
	Description: Sets the required task for the traversing block. <ul style="list-style-type: none"> • 1: POSITIONING • 2: FIXED STOP • 3: ENDLESS_POS • 4: ENDLESS_NEG • 5: WAIT • 6: GOTO • 7: SET_O • 8: RESET_O • 9: JERK 							
	Dependency: Refer to: p2617, p2618, p2619, p2620, p2622, p2623							
p2622[0...15]	EPOS traversing block task parameter	-2147483648	2147483647	0	-	I32	IM	T, U
	Description: Sets additional information/data of the appropriate task for the traversing block.							
	Dependency: Refer to: p2617, p2618, p2619, p2620, p2621, p2623 Note: The following should be set depending on the task: FIXED STOP: Clamping torque and clamping force (rotary 0...65536 [0.01 Nm], linear 0...65536 [N]) WAIT: Delay time [ms] GOTO: Block number SET_O: 1, 2 or 3 - set direct output 1, 2 or 3 (both) RESET_O: 1, 2 or 3 - reset direct output 1, 2 or 3 (both) JERK: 0 - deactivate, 1 - activate							

11.2 Parameter list

Par. No.	Name	Min	Max	Factory Setting	Unit	Data type	Effective	Can be changed
p2623[0...15]	EPOS traversing block task mode	0	65535	0	-	U16	IM	T, U
	Description: Sets the influence of the task for the traversing block. Value = 0000 cccc bbbb aaaa cccc: Positioning mode cccc = 0000: ABSOLUTE cccc = 0001: RELATIVE cccc = 0010: ABS_POS (only for a rotary axis with modulo correction) cccc = 0011: ABS_NEG (only for a rotary axis with modulo correction) bbbb: Progression condition bbbb = 0000: END bbbb = 0001: CONTINUE WITH STOP bbbb = 0010: CONTINUE FLYING bbbb = 0011: CONTINUE EXTERNAL bbbb = 0100: CONTINUE EXTERNAL WAIT bbbb = 0101: CONTINUE EXTERNAL ALARM aaaa: IDs aaaa = 000x: show/hide block (x = 0: show; x = 1: hide)							
	Dependency: Refer to: p2617, p2618, p2619, p2620, p2621, p2622							
p2634	EPOS fixed stop maximum following error	0	2147482647	1000	LU	U32	IM	T, U
	Description: Sets the following error to detect the "fixed stop reached" state.							
	Dependency: Refer to: p2621							
	Note: The state "fixed stop reached" is detected if the following error exceeds the theoretically calculated following error value by p2634.							
p2635	EPOS fixed stop monitoring window	0	2147482647	100	LU	U32	IM	T, U
	Description: Sets the monitoring window of the actual position after the fixed stop is reached.							
	Dependency: Refer to: F07484							
	Note: If, after the fixed stop is reached, the end stop shifts in either the positive or negative direction by more than the value set here, an appropriate message is output.							
p2690	MDI position fixed setpoint	-2147482648	2147482647	0	-	I32	IM	T, U
	Description: Sets a fixed setpoint for the position.							
p2691	MDI velocity fixed setpoint	1	40000000	600	100 0 L U/mi n	U32	IM	T, U
	Description: Sets a fixed setpoint for the speed.							
p2692	MDI acceleration override, fixed setpoint	0.100	100.000	100.000	%	Float	IM	T, U
	Description: Sets a fixed setpoint for the acceleration override.							
	Dependency: Refer to: p2572							
	Note: The percentage value refers to the maximum acceleration (p2572).							

Par. No.	Name	Min	Max	Factory Setting	Unit	Data type	Effective	Can be changed
p2693	MDI deceleration override, fixed setpoint	0.100	100.000	100.000	%	Float	IM	T, U
	Description: Sets a fixed setpoint for the deceleration override.							
	Dependency: Refer to: p2572							
Note: The percentage value refers to the maximum deceleration (p2573).								
p8920[0...239]	PROFIdrive: Name of station	-	-	-	-	U8	IM	T, U
	Description: Sets the station name for the onboard PROFINET interface on the Control Unit. The active station name is displayed in r8930.							
	Note: The interface configuration (p8920 and following) is activated with p8925. The parameter is not influenced by setting the factory setting.							
p8921[0...3]	PROFIdrive: IP address of station	0	255	0	-	U8	IM	T, U
	Description: Sets the IP address for the onboard PROFINET interface on the Control Unit. The active IP address is displayed in r8931.							
	Note: The interface configuration (p8920 and following) is activated with p8925. The parameter is not influenced by setting the factory setting.							
p8922[0...3]	PROFIdrive: Default gateway of station	0	255	0	-	U8	IM	T, U
	Description: Sets the default gateway for the onboard PROFINET interface on the Control Unit. The active default gateway is displayed in r8932.							
	Note: The interface configuration (p8920 and following) is activated with p8925. The parameter is not influenced by setting the factory setting.							
p8923[0...3]	PROFIdrive: Subnet mask of station	0	255	0	-	U8	IM	T, U
	Description: Sets the subnet mask for the onboard PROFINET interface on the Control Unit. The active subnet mask is displayed in r8933.							
	Note: The interface configuration (p8920 and following) is activated with p8925. The parameter is not influenced by setting the factory setting.							
p8925	PROFIdrive: Interface configuration	0	3	0	-	U8	IM	T, U
	Description: Setting to activate the interface configuration for the onboard PROFINET interface on the Control Unit. p8925 is automatically set to 0 at the end of the operation. <ul style="list-style-type: none"> • p8925 = 0: No function • p8925 = 2: Save and activate configuration The interface configuration (p8920 and following) is saved and activated after the next POWER ON.							
p29000 *	Motor ID	0	65535	0	-	U16	IM	T
	Description: Motor type number is printed on the motor rating plate as motor ID. For a motor with an incremental encoder, users need to manually input the parameter value. For a motor with an absolute encoder, the drive automatically reads the parameter value.							

11.2 Parameter list

Par. No.	Name	Min	Max	Factory Setting	Unit	Data type	Effective	Can be changed
p29001	Reversal of motor direction	0	1	0	-	I16	IM	T
	<p>Description: Reversal of motor running direction. By default, CW is the positive direction while CCW the negative direction. After changing of p29001, reference point will lost, A7461 will remind user to referencing again.</p> <ul style="list-style-type: none"> 0: No reversal 1: Reverse 							
p29002	BOP display selection	0	4	0	-	I16	IM	T, U
	<p>Description: Selection of BOP operating display.</p> <ul style="list-style-type: none"> 0: Actual speed (default) 1: DC voltage 2: Actual torque 3: Actual position 4: Position following error 							
p29003	Control mode	1	2	2	-	I16	IM	T
	<p>Description: Selection of control mode.</p> <ul style="list-style-type: none"> 1: Basic positioner control mode (EPOS) 2: Speed control mode (S) 							
p29005	Braking resistor capacity percentage alarm threshold	1	100	100	%	Float	IM	T
	<p>Description: Alarm triggering threshold for the capacity of the internal braking resistor. Alarm number: A52901</p>							
p29006	Line supply voltage	200	480	400/230	V	U16	IM	T
	<p>Description: Nominal Line supply voltage, effective value of line to line voltage. Drive can operate within -15% to +10% error. For 400 V variant servo drive, the value range is 380 V to 480 V, default value is 400 V. For 200 V variant servo drive, the value range is 200 V to 240 V, default value is 230 V.</p>							
p29020[0..1]	Tuning: Dynamic factor	1	35	18	-	U16	IM	T, U
	<p>Description: The dynamic factor of auto tuning. 35 dynamic factors in total are available.</p> <p>Index:</p> <ul style="list-style-type: none"> [0]: Dynamic factor for one-button auto tuning [1]: Dynamic factor for real-time auto tuning 							
p29021	Tuning: Mode selection	0	5	0	-	I16	IM	T
	<p>Description: Selection of a tuning mode.</p> <ul style="list-style-type: none"> 0: Disabled 1: One-button auto tuning 3: Real-time auto tuning 5: Disable with default controller parameters 							
p29022	Tuning: Ratio of total inertia moment to motor inertia moment	1.00	10000.00	1.00	-	Float	IM	T, U
	<p>Description: Ratio of total inertia moment to servo motor inertia moment.</p>							

Par. No.	Name	Min	Max	Factory Setting	Unit	Data type	Effective	Can be changed
p29023	Tuning: One-button auto tuning configuration	-	-	0x0007	-	U16	IM	T
	<p>Description: One-button auto tuning configuration.</p> <ul style="list-style-type: none"> • Bit 0: The speed controller gain is determined and set using a noise signal. • Bit 1: Possible required current setpoint filters are determined and set using a noise signal. As a consequence, a higher dynamic performance can be achieved in the speed control loop. • Bit 2: The inertia moment ratio (p29022) can be measured after this function is running. If not set, the inertia moment ratio must be set manually with p29022. • Bit 7: With this bit set, multi-axes are adapted to the dynamic response set in p29028. This is necessary for interpolating axes. The time in p29028 should be set according to the axis with the lowest dynamic response. 							
p29024	Tuning: Real-time auto tuning configuration	-	-	0x004c	-	U16	IM	T
	<p>Description: Real-time auto tuning configuration.</p> <ul style="list-style-type: none"> • Bit 2: The inertia moment ratio (p29022) is estimated while the motor is running, if not set, the inertia moment ratio must be set manually with p29022. • Bit 3: If not set, the inertia moment ratio (p29022) is estimated only once and the inertia estimator is deactivated automatically after the estimation is completed. If the bit is set to 1, the inertia moment ratio is estimated in real time and the controller adapts the parameters continuously. You are recommended to save the parameters when the estimation result is satisfied. After that, when you power on the drive next time, the controller will be started with the optimized parameters. • Bit 6: The adaption of current setpoint filter. This adaption may be necessary if a mechanical resonance frequency changes in operation. It can also be used to dampen a fixed resonance frequency. Once the control loop has stabilized, this bit should be deactivated and to save parameters in a non-volatile memory. • Bit 7: With this bit set, multi-axes are adapted to the dynamic response set in p29028. This is necessary for interpolating axes. The time in p29028 should be set according to the axis with the lowest dynamic response. 							
p29025	Tuning: Configuration overall	-	-	0x0004	-	U16	IM	T
	<p>Description: Overall configuration of auto tuning, apply for both one-button and real-time auto tuning.</p> <ul style="list-style-type: none"> • Bit 0: For significant differences between the motor and load moment of inertia, or for low dynamic performance of the controller, then the P controller becomes a PD controller in the position control loop. As a consequence, the dynamic performance of the position controller is increased. This function should only be set when the speed pre-control (bit 3 = 1) or the torque pre-control (bit 4 = 1) is active. • Bit 1: At low speeds, the controller gain factors are automatically reduced in order to avoid noise and oscillation at standstill. This setting is recommended for incremental encoders. • Bit 2: The estimated load moment of inertia is taken into account for the speed controller gain. • Bit 3: Activates the speed pre-control for the position controller. • Bit 4: Activates the torque pre-control for the position controller. • Bit 5: Adapts acceleration limit. 							
p29026	Tuning: Test signal duration	0	5000	2000	ms	U32	IM	T
	<p>Description: The duration time of the one-button auto tuning test signal.</p>							

11.2 Parameter list

Par. No.	Name	Min	Max	Factory Setting	Unit	Data type	Effective	Can be changed
p29027	Tuning: Limit rotation of motor	0	30000	0	°	U32	IM	T
	Description: The limit position with motor rotations during one-button auto tuning. The traversing range is limited within +/- p29027 degrees (motor run one revolution is 360 degree).							
p29028	Tuning: Pre-control time constant	0.0	60.0	7.5	ms	Float	IM	T, U
	Description: Sets the time constant for the pre-control symmetrization for auto tuning. As a consequence, the drive is allocated a defined, dynamic response via its pre-control. For drives, which must interpolate with one another, the same value must be entered. The higher this time constant is, the smoother the drive will follow the position set point. Note: This time constant is only effective when multi-axis interpolation is selected (bit 7 of p29023 and p29024).							
p29035	VIBSUP activation	0	1	0	-	I16	IM	T
	Description: Select the VIBSUP ON/OFF. Position setpoint filter can be activated (p29035) for EPOS control mode. <ul style="list-style-type: none"> • 0: Disable Filter is not activated. • 1: Enable Filter is activated. 							
p29050[0.. .1]	Torque limit upper	-150	300	300	%	Float	IM	T, U
	Description: Positive torque limit. Two internal torque limits in total are available. You can select the internal parameters as the source of the torque limit with the digital input signals TLIM.							
p29051[0.. .1]	Torque limit lower	-300	150	-300	%	Float	IM	T, U
	Description: Negative torque limit. Two internal torque limits in total are available. You can select the internal parameters as the source of the torque limit with the digital input signals TLIM.							
p29070[0.. .1] *	Speed limit positive	0	210000	210000	rpm	Float	IM	T, U
	Description: Positive speed limit. Two internal speed limits in total are available. You can select the internal parameters as the source of the speed limit with the digital input signals SLIM.							
p29071[0.. .1] *	Speed limit negative	-210000	0	- 210000	rpm	Float	IM	T, U
	Description: Negative speed limit. Two internal speed limits in total are available. You can select the internal parameters as the source of the speed limit with the digital input signals SLIM.							
p29080	Overload threshold for output signal triggering	10	300	100	%	Float	IM	T
	Description: Overload threshold for the output power.							

Par. No.	Name	Min	Max	Factory Setting	Unit	Data type	Effective	Can be changed
p29108	Function module activate	0	0xffffffff	0	-	U32	RE	T
<p>Description: Bit 0: activate extended setpoint channel including ramp-function generator (RFG), speed limit (SLIM), and JOG.</p> <ul style="list-style-type: none"> • Bit 0 = 0: Deactivate • Bit 0 = 1: Activate <p>Note: Changes only become effective after save and repower-on. Currently, you can set bit 0 only.</p>								
p29110 **	Position loop gain	0.000	300.000	1.800	100 0/mi n	Float	IM	T, U
<p>Description: Position loop gain. Two position loop gains in total are available. You can switch between these two gains by configuring the digital input signal G-CHANGE or setting relevant condition parameters. The first position loop gain is the default setting.</p> <p>Dependency: The parameter value will be set to default after configuring a new motor ID (p29000).</p>								
p29111	Speed pre-control factor (feed forward)	0.00	200.00	0.00	%	Float	IM	T, U
<p>Description: Setting to activate and weight the speed pre-control value. Value = 0%: The pre-control is deactivated.</p>								
p29120**	Speed loop gain	0.00	999999.00	Motor de- pendent	Nms /rad	Float	IM	T, U
<p>Description: Speed loop gain.</p> <p>Dependency: The parameter value will be set to default after configuring a new motor ID (p29000).</p>								
p29121*	Speed loop integral time	0.00	100000.00	15	ms	Float	IM	T, U
<p>Description: Speed loop integral time.</p> <p>Dependency: The parameter value will be set to default after configuring a new motor ID (p29000).</p>								
p29150	User defined PZD receive	0	2	0	-	16	IM	T
<p>Description: Select the function of control PZD12 when using telegram 111.</p> <ul style="list-style-type: none"> • 0: No function • 1: Additional torque setpoint • 2: Additional speed setpoint 								
p29151	User defined PZD send	0	3	0	-	16	IM	T
<p>Description: Select the function of status PZD12 when using telegram 111.</p> <ul style="list-style-type: none"> • 0: No function • 1: Actual torque • 2: Actual absolute current • 3: DI status 								

Par. No.	Name	Min	Max	Factory Setting	Unit	Data type	Effective	Can be changed
p29230	MDI direction selection	0	2	0	-	I16	IM	T
	Description: MDI direction selection: <ul style="list-style-type: none"> 0: Absolute positioning through the shortest distance 1: Absolute positioning in the positive direction 2: Absolute positioning in the negative direction 							
	Dependency: This parameter is only valid for modulo axis (p29245 = 1).							
p29231	MDI positioning type	0	1	0	-	I16	IM	T
	Description: MDI positioning type: <ul style="list-style-type: none"> 0: Relative positioning 1: Absolute positioning 							
p29240	Select referencing mode	0	2	1	-	I16	IM	T
	Description: Selects referencing mode. <ul style="list-style-type: none"> 0: Referencing with external signal REF 1: Referencing with external reference cam (signal REF) and encoder zero mark 2: Referencing with zero mark only 							
p29243	Positioning tracking activate	0	1	0	-	I16	IM	T
	Description: Activation of position tracking. <ul style="list-style-type: none"> 0: Deactivated 1: Activated 							
p29244	Absolute encoder virtual rotary revolutions	0	4096	0	-	U32	IM	T
	Description: Sets the number of rotations that can be resolved for an encoder with activated position tracking function (p29243 = 1).							
p29245	Axis mode state	0	1	0	-	U32	IM	T
	Description: Linear/modulo mode: <ul style="list-style-type: none"> 0: Linear axis 1: Modulo axis 							
p29246 *	Modulo correction range	1	214748264 7	360000	-	U32	IM	T
	Description: Modulo number, effective on modulo mode (P29245=1)							
p29247 *	Mechanical gear: LU per revolution	1	214748364 7	10000	-	U32	IM	T
	Description: LU per load revolution.							
p29248 *	Mechanical gear: Numerator	1	1048576	1	-	U32	IM	T
	Description: (Load/Motor) Load revolutions.							
p29249 *	Mechanical gear: Denominator	1	1048576	1	-	U32	IM	T
	Description: (Load/Motor) Motor revolutions.							

Par. No.	Name	Min	Max	Factory Setting	Unit	Data type	Effective	Can be changed
p29301	Digital input 1 assignment	0	29	2	-	l16	IM	T
	Description: Defines the function of digital input signal DI1 <ul style="list-style-type: none"> • 0: NA • 2: RESET • 3: CWL • 4: CCWL • 11: TLIM • 20: SLIM • 24: REF • 29: EMGS 							
p29302	Digital input 2 assignment	0	29	11	-	l16	IM	T
	Description: Defines the function of digital input signal DI2							
p29303	Digital input 3 assignment	0	29	0	-	l16	IM	T
	Description: Defines the function of digital input signal DI3							
p29304	Digital input 4 assignment	0	29	0	-	l16	IM	T
	Description: Defines the function of digital input signal DI4							
p29330	Digital output 1 assignment	1	15	2	-	l16	IM	T
	Description: Defines the function of digital output signal DO1 <ul style="list-style-type: none"> • 1: RDY • 2: FAULT • 3: INP • 4: ZSP • 6: TLR • 8: MBR • 9: OLL • 12: REFOK • 14: RDY_ON • 15: STO_EP 							
p29331	Digital output 2 assignment	1	15	9	-	l16	IM	T
	Description: Defines the function of digital output signal DO2							
p29360	Brake resistor alarm active	0	1	1	-	l16	IM	T, U
	Description: Configure the deactivation of the brake resistor alarm. <ul style="list-style-type: none"> • 0: A52901 monitor is activated. • 1: A52901 monitor is deactivated. 							

11.2 Parameter list

Par. No.	Name	Min	Max	Factory Setting	Unit	Data type	Effective	Can be changed
p29418	Fine resolution G1_XIST1 (in bits)	2	18	11	-	U8	IM	T
	Description: Sets the fine resolution in bits of the incremental position actual values G1_XIST1.							
	Note: The fine resolution specifies the fraction between two encoder pluses. The number of pulses for one encoder revolution is 2048, so the effective resolution is 2048×2^{p29418} . The default value is automatically adjusted with the encoder type.							
p29419	Fine resolution G1_XIST2 (in bits)	2	18	9	-	U8	IM	T
	Description: Sets the fine resolution in bits of the absolute position actual values G1_XIST2.							
	Note: The fine resolution specifies the fraction between two encoder pluses. The number of pulses for one encoder revolution is 2048, so the effective resolution is 2048×2^{p29419} . The default value is automatically adjusted with the encoder type.							
p31581	VIBSUP filter type	0	1	0	-	I16	IM	T
	Description: Sets the filter type for VIBSUP. Depending on the selected filter type, the VIBSUP filter results in motion sequences that take somewhat longer.							
	<ul style="list-style-type: none"> 0: The rugged VIBSUP filter has a lower sensitivity to frequency offsets compared with the sensitive filter type, but results in a higher delay of the motion sequence. The total motion sequence is extended by the time period T_d ($T_d = 1/f_d$). 1: The sensitive VIBSUP filter has a higher sensitivity to frequency offsets compared with the rugged filter type, but results in a lower delay of the motion sequence. The total motion sequence is extended by half the time period $T_d/2$ ($T_d = 1/f_d$). 							
p31585	VIBSUP filter frequency	0.5	62.5	1	Hz	Float	IM	T
	Description: Sets the frequency of the damped natural vibration of the mechanical system. This frequency can be determined by making the appropriate measurements.							
	Note: The maximum frequency that can be set depends on the filter sampling time.							
p31586	VIBSUP filter damping	0	0.99	0.03	-	Float	IM	T
	Description: Sets the value for the damping of the natural mechanical vibration to be filtered. Typically, the damping value is about 0.03, and can be optimized by performing the appropriate positioning tests.							

Read-only parameters

Par. No.	Name	Unit	Data type
r0020	Speed setpoint smoothed	rpm	Float
	Description: Displays the currently smoothed speed setpoint at the input of the speed controller or U/f characteristic (after the interpolator).		
	Note: Smoothing time constant = 100 ms The signal is not suitable as a process quantity and may only be used as a display quantity. The speed setpoint is available smoothed (r0020) and unsmoothed.		
r0021	Actual speed smoothed	rpm	Float
	Description: Displays the smoothed actual value of the motor speed.		
	Note: Smoothing time constant = 100 ms The signal is not suitable as a process quantity and may only be used as a display quantity. The speed actual value is available smoothed (r0021) and unsmoothed.		
r0026	DC link voltage smoothed	V	Float
	Description: Displays the smoothed actual value of the DC link voltage.		
	Note: Smoothing time constant = 100 ms The signal is not suitable as a process quantity and may only be used as a display quantity. The DC link voltage is available smoothed.		
r0027	Absolute actual current smoothed	Arms	Float
	Description: Displays the smoothed absolute actual current value.		
	Notice: This smoothed signal is not suitable for diagnostics or evaluation of dynamic operations. In this case, the unsmoothed value should be used.		
	Note: Smoothing time constant = 100 ms The signal is not suitable as a process quantity and may only be used as a display quantity. The absolute current actual value is available smoothed (r0027) and unsmoothed.		
r0029	Current actual value field-generating smoothed	Arms	Float
	Description: Displays the smoothed field-generating actual current.		
	Note: Smoothing time constant = 100 ms The signal is not suitable as a process quantity and may only be used as a display quantity. The field-generating current actual value is available smoothed (r0029) and unsmoothed.		
r0030	Current actual value torque-generating smoothed	Arms	Float
	Description: Displays the smoothed torque-generating actual current.		
	Note: Smoothing time constant = 100 ms The signal is not suitable as a process quantity and may only be used as a display quantity. The torque-generating current actual value is available smoothed.		
r0031	Actual torque smoothed	Nm	Float
	Description: Displays the smoothed torque actual value.		
	Note: Smoothing time constant = 100 ms The signal is not suitable as a process quantity and may only be used as a display quantity. The torque actual value is available smoothed (r0031) and unsmoothed.		
r0034	Motor utilization thermal	%	Float
	Description: Displays the motor utilization from motor temperature model 1 (I ² t) or 3.		

11.2 Parameter list

Par. No.	Name	Unit	Data type
r0037[0...19]	Power unit temperatures	°C	Float
	Description: Displays the temperatures in the power unit.		
	Index:		
	<ul style="list-style-type: none"> • [0]: Inverter maximum value • [1]: Depletion layer maximum value • [2]: Rectifier maximum value • [3]: Air intake • [4]: Interior of power unit • [5]: Inverter 1 • [6]: Inverter 2 • [7]: Inverter 3 • [8]: Inverter 4 • [9]: Inverter 5 • [10]: Inverter 6 • [11]: Rectifier 1 • [12]: Rectifier 2 • [13]: Depletion layer 1 • [14]: Depletion layer 2 • [15]: Depletion layer 3 • [16]: Depletion layer 4 • [17]: Depletion layer 5 • [18]: Depletion layer 6 • [19]: Cooling unit liquid intake 		
	Dependency: Refer to A01009		
	Notice: Only for internal Siemens troubleshooting. Note: The value of -200 indicates that there is no measuring signal. <ul style="list-style-type: none"> • r0037[0]: Maximum value of the inverter temperatures (r0037[5...10]). • r0037[1]: Maximum value of the depletion layer temperatures (r0037[13...18]). • r0037[2]: Maximum value of the rectifier temperatures (r0037[11...12]). The maximum value is the temperature of the hottest inverter, depletion layer, or rectifier.		
r0079[0...1]	Torque setpoint total	Nm	Float
	Description: Displays and connector output for the torque setpoint at the output of the speed controller (before clock cycle interpolation). Index: <ul style="list-style-type: none"> • [0]: Unsmoothed • [1]: Smoothed 		
r0296	DC link voltage undervoltage threshold	V	U16
	Description: Threshold to detect a DC link undervoltage. If the DC link voltage falls below this threshold, the drive unit is tripped due to a DC link undervoltage condition. Note: The value depends on the device type and the selected device rated voltage.		

Par. No.	Name	Unit	Data type
r0297	DC link voltage overvoltage threshold	V	U16
	Description: If the DC link voltage exceeds the threshold specified here, the drive unit is tripped due to DC link overvoltage.		
	Dependency: Refer to F30002.		
r0311	Rated motor speed	rpm	Float
	Description: Displays the rated motor speed (rating plate).		
r0333	Rated motor torque	Nm	Float
	Description: Displays the rated motor torque.		
	IEC drive: unit Nm NEMA drive: unit lbf ft		
r0482[0...2]	Encoder actual position value Gn_XIST1	-	U32
	Description: Displays the encoder actual position value Gn_XIST1 .		
	Index:		
	<ul style="list-style-type: none"> • [0]: Encoder 1 • [1]: Encoder 2 • [2]: Reserved 		
Note:			
<ul style="list-style-type: none"> • In this value, the measuring gear is only taken into account when the position tracking is activated. • The update time for the position control (EPOS) corresponds to the position controller clock cycle. • The update time in isochronous operation corresponds to the bus cycle time. • The update time in isochronous operation and with position control (EPOS) corresponds to the position controller clock cycle. • The update time in non-isochronous operation or without position control (EPOS) comprises the following: <ul style="list-style-type: none"> – Update time = 4 * least common multiple (LCM) of all current controller clock cycles in the drive group (infeed + drives). The minimum update time is 1 ms. – Example 1: infeed, servo Update time = 4 * LCM(250 µs, 125 µs) = 4 * 250 µs = 1 ms – Example 2: infeed, servo, vector Update time = 4 * LCM(250 µs, 125 µs, 500 µs) = 4 * 500 µs = 2 ms 			
r0632	Motor temperature model, stator winding temperature	°C	Float
	Description: Displays the stator winding temperature of the motor temperature model.		
r0722	CU digital inputs status	-	U32
	Description: Displays the status of the digital inputs.		
	Note: DI: Digital Input DI/DO: Bidirectional Digital Input/Output The drive unit displays the value in hex format. You can convert the hex number to the binary number, for example, FF (hex) = 11111111 (bin).		
r0747	CU digital outputs status	-	U32
	Description: Displays the status of digital outputs.		
	Note: DI/DO: Bidirectional Digital Input/Output The drive unit displays the value in hex format. You can convert the hex number to the binary number, for example, FF (hex) = 11111111 (bin).		

11.2 Parameter list

Par. No.	Name	Unit	Data type
r0930	PROFIdrive operating mode	-	U16
	Description: Displays the operating mode. <ul style="list-style-type: none"> • 1: Closed-loop speed controlled operation with ramp-function generator • 2: Closed-loop position controlled operation • 3: Closed-loop speed controlled operation without ramp-function generator 		
r0945[0...63]	Fault code	-	U16
	Description: Displays the number of faults that have occurred.		
	Dependency: Refer to r0949		
	Note: The buffer parameters are cyclically updated in the background. Fault buffer structure (general principle): r0945[0], r0949[0] → actual fault case, fault 1 ... r0945[7], r0949[7] → actual fault case, fault 8 r0945[8], r0949[8] → 1st acknowledged fault case, fault 1 ... r0945[15], r0949[15] → 1st acknowledged fault case, fault 8 ... r0945[56], r0949[56] → 7th acknowledged fault case, fault 1 ... r0945[63], r0949[63] → 7th acknowledged fault case, fault 8		
r0949[0...63]	Fault value	-	I32
	Description: Displays additional information about the fault that occurred (as integer number).		
	Dependency: Refer to r0945 Note: The buffer parameters are cyclically updated in the background. The structure of the fault buffer and the assignment of the indices is shown in r0945.		
r0964[0...6]	Device identification	-	U16
	Description: Displays the device identification.		
	Index: <ul style="list-style-type: none"> • [0]: Company (Siemens = 42) • [1]: Device type • [2]: Firmware version • [3]: Firmware data (year) • [4]: Firmware data (day/month) • [5]: Number of drive objects • [6]: Firmware patch/hot fix Note: Example: r0964[0] = 42 → SIEMENS r0964[1] = Device type r0964[2] = 403 → First part of the firmware version V04.03 (for second part, refer to index 6) r0964[3] = 2010 → Year 2010 r0964[4] = 1705 → 17th of May r0964[5] = 2 → 2 drive objects r0964[6] = 200 → Second part, firmware version (complete version: V04.03.02.00)		

Par. No.	Name	Unit	Data type
r0965	PROFIdrive profile number	-	U16
	<p>Description: Displays the PROFIdrive profile and profile version. Constant value = 0329 hex Byte 1: Profile number = 03 hex = PROFIdrive profile Byte 2: Profile version = 29 hex = Version 4.1</p> <p>Note: When the parameter is read via PROFIdrive, the Octet String 2 data type applies.</p>		
r0975[0...10]	Drive object identification	-	U16
	<p>Description: Displays the identification of the drive object.</p> <p>Index:</p> <ul style="list-style-type: none"> • [0]: Company (Siemens = 42) • [1]: Drive object type • [2]: Firmware version • [3]: Firmware data (year) • [4]: Firmware data (day/month) • [5]: PROFIdrive drive object type class • [6]: PROFIdrive drive object sub-type class 1 • [7]: Drive object number • [8]: Reserved • [9]: Reserved • [10]: Firmware patch/hot fix <p>Note: Example: r0975[0] = 42 → SIEMENS r0975[1] = SERVO drive object type r0975[2] = 102 → First part of the firmware version V01.02 (for second part, refer to index 10) r0975[3] = 2003 → Year 2003 r0975[4] = 1401 → 14th of January r0975[5] = 1 → PROFIdrive drive object, type class r0975[6] = 9 → PROFIdrive drive object sub-type class 1 r0975[7] = 2 → Drive object number = 2 r0975[8] = 0 (Reserved) r0975[9] = 0 (Reserved) r0975[10] = 600 → Sencod part, firmware version (complete version: V01.02.06.00)</p>		
r0979[0...30]	PROFIdrive encoder format	-	U32
	<p>Description: Displays the actual position encoder used according to PROFIdrive.</p> <p>Index:</p> <ul style="list-style-type: none"> • [0]: Header • [1]: Type encoder 1 • [2]: Resolution encoder 1 • [3]: Shift factor G1_XIST1 • [4]: Shift factor G1_XIST2 • [5]: Distinguishable revolutions encoder 1 • [6]...[30]: Reserved <p>Note: Information about the individual indices can be taken from the following literature: PROFIdrive Profile Drive Technology</p>		

Par. No.	Name	Unit	Data type
r2043.0...2	PROFIdrive: PZD state	-	U8
	<p>Description: Displays the PROFIdrive PZD state.</p> <p>Bit 0: Setpoint failure</p> <ul style="list-style-type: none"> Value = 1: Yes Vaule = 0: No <p>Bit 1: Clock cycle synchronous operation active</p> <ul style="list-style-type: none"> Vaule = 1: Yes Vaule = 0: No <p>Bit 2: Fieldbus operation</p> <ul style="list-style-type: none"> Value = 1: Yes Vaule = 0: No <p>Note: When using the "setpoint failure" signal, the bus can be monitored and an application-specific response triggered when the setpoint fails.</p>		
r2050[0...19]	PROFIdrive: PZD receive word	-	I16
	<p>Description: Displays the PZD (setpoints) with word format received from the fieldbus controller.</p> <p>Dependency: Refer to r2060.</p> <p>Index: Index 0 to index 19 stand for PZD1 to PZD20 correspondingly.</p>		
r2053[0...27]	PROFIdrive: Diagnostics PZD send word	-	U16
	<p>Description: Displays the PZD (actual values) with word format send to the fieldbus controller.</p> <p>Index: Index 0 to index 27 stand for PZD1 to PZD28 correspondingly.</p> <p>Bit field: For each PZD, it has 16 bits from bit 0 to bit 15. For the control words, if the bit value equals to 0, the function of the bit is OFF; if the bit vaule equals to 1, the function of the bit is ON.</p>		
r2060[0...18]	PROFIdrive: PZD receive double word	-	I32
	<p>Description: Displays the PZD (setpoints) with double word format received from the fieldbus controller.</p> <p>Dependency: Refer to r2050.</p> <p>Index: Index [n] = PZD[n + 1] + n + 2 In the formula, n = 0...18.</p> <p>Notice: A maximum of 4 indices of the "trace" function can be used.</p>		
r2063[0...26]	PROFIdrive: Diagnostics PZD send double word	-	U32
	<p>Description: Displays the PZD (actual values) with double word format send to the fieldbus controller.</p> <p>Index: Index [n] = PZD[n + 1] + n + 2 In the formula, n = 0...26.</p> <p>Bit field: For each PZD, it has 32 bits from bit 0 to bit 31. For the control words, if the bit value equals to 0, the function of the bit is OFF; if the bit vaule equals to 1, the function of the bit is ON.</p> <p>Notice: A maximum of 4 indices of the "trace" function can be used.</p>		

Par. No.	Name	Unit	Data type
r2090.0...1 5	PROFIdrive: PZD1 receive bit-serial	-	U16
	Description: Bit-serial description of PZD1 (normally control word 1) received from the PROFIdrive controller. If the value of the bit equals to 0, it means the function of this bit is deactivated. If the value of the bit equals to 1, it means the function of this bit is activated.		
r2091	PROFIdrive: PZD2 receive bit-serial	-	U16
	Description: Binector output for bit-serial interconnection of PZD2 received from the PROFIdrive controller.		
r2092	PROFIdrive: PZD3 receive bit-serial	-	U16
	Description: Binector output for bit-serial interconnection of PZD3 received from the PROFIdrive controller.		
r2093.0...1 5	PROFIdrive: PZD4 receive bit-serial	-	U16
	Description: Bit-serial description of PZD4 (normally control word 2) received from the PROFIdrive controller. If the value of the bit equals to 0, it means the function of this bit is deactivated. If the value of the bit equals to 1, it means the function of this bit is activated.		
r2094	PROFIdrive: MDI_MOD receive bit-serial for telegram 9	-	U16
	Description: Binector output for bit-serial onward interconnection of a PZD word received from the PROFIdrive controller.		
r2122[0...6 3]	Alarm code	-	U16
	Description: Displays the number of faults that have occurred.		
	Dependency: Refer to r2124		
	Note: The buffer parameters are cyclically updated in the background. Alarm buffer structure (general principle): r2122[0], r2124[0] → alarm 1 (the oldest) ... r2122[7], r2124[7] → alarm 8 (the latest) When the alarm buffer is full, the alarms that have gone are entered into the alarm history: r2122[8], r2124[8] → alarm 1 (the latest) ... r2122[63], r2124[63] → alarm 1 (the oldest)		
r2124[0...6 3]	Alarm value	-	I32
	Description: Displays additional information about the active alarm (as integer number).		
	Dependency: Refer to r2122		
	Note: The buffer parameters are cyclically updated in the background. The structure of the alarm buffer and the assignment of the indices is shown in r2122.		
r2521[0...3]	LR position actual value	LU	I32
	Description: Display and connector output for the actual position actual value determined by the position actual value preprocessing. Index: <ul style="list-style-type: none"> • [0]: CI-loop position control • [1]: Encoder 1 • [2]: Encoder 2 • [3]: Reserved 		
r2556	LR position setpoint after setpoint smoothing	LU	I32
	Description: Display and connector output for the position setpoint after setpoint smoothing.		

11.2 Parameter list

Par. No.	Name	Unit	Data type
r2563	LR following error dynamic model	LU	I32
	Description: Display and connector output for the dynamic following error. This value is the deviation, corrected by the velocity-dependent component, between the position setpoint and the position actual value.		
r2665	EPOS position setpoint	LU	I32
	Description: Displays the actual absolute position setpoint.		
r8909	PROFIdrive: Device ID	-	U16
	Description: Displays the PROFINET device ID. Every SINAMICS device type has its own PROFINET device ID and its own PROFINET GSD.		
r8930[0...239]	PROFIdrive: Active name of station	-	U8
	Description: Displays the active station name for the onboard PROFINET interface on the Control Unit.		
r8931[0...31]	PROFIdrive: Active IP address of station	-	U8
	Description: Displays the active IP address for the onboard PROFINET interface on the Control Unit.		
r8932[0...31]	PROFIdrive: Active default gateway of station	-	U8
	Description: Displays the active default gateway for the onboard PROFINET interface on the Control Unit.		
r8933[0...31]	PROFIdrive: Active subnet mask of station	-	U8
	Description: Displays the active subnet mask for the onboard PROFINET interface on the Control Unit.		
r8935	PROFIdrive: MAC address of station	-	U8
	Description: Displays the MAC address for the onboard PROFINET interface on the Control Unit.		
r8939	PROFIdrive: Device access point (DAP) ID	-	U32
	Description: Displays the PROFINET device access point ID for the onboard PROFINET interface. The combination of device ID (r8909) and DAP ID uniquely identifies a PROFINET access point.		
r29018[0...1]	OA version	-	Float
	Description: Displays the OA version.		
	Index: <ul style="list-style-type: none"> • [0]: Firmware version • [1]: Build increment number 		
r29400	Internal control signal status indicating	-	U32
	Description: Control signal status identifiers The bits of the parameter are reserved except the following ones: <ul style="list-style-type: none"> • Bit 1: RESET • Bit 2: CWL • Bit 3: CCWL • Bit 10: TLIM • Bit 19: SLIM • Bit 23: REF • Bit 28: EMGS 		

Par. No.	Name	Unit	Data type
r29942	DO signals status indicating	-	U32
	Description: Indicates the status of DO signals. <ul style="list-style-type: none">• Bit 0: RDY• Bit 1: FAULT• Bit 2: Reserved• Bit 3: ZSP• Bit 4: Reserved• Bit 5: TLR• Bit 6: Reserved• Bit 7: MBR• Bit 8: OLL• Bit 9: Reserved• Bit 10: Reserved• Bit 11: Reserved• Bit 12: Reserved• Bit 13: RDY_ON• Bit 14: STO_EP		

Diagnostics

12.1 Overview

General information about faults and alarms

The errors and states detected by the individual components of the drive system are indicated by messages.

The messages are categorized into faults and alarms.

Properties of faults and alarms

- Faults
 - Are identified by Fxxxxx.
 - Can lead to a fault reaction.
 - Must be acknowledged once the cause has been remedied.
 - Status via control unit and LED RDY.
 - Status via PROFINET status word ZSW1.3.
 - Entry in the fault buffer.
- Alarms
 - Are identified by Axxxxx.
 - Have no further effect on the drive.
 - The alarms are automatically reset once the cause has been remedied. No acknowledgement is required.
 - Status via Control Unit and LED RDY.
 - Status via PROFINET status word ZSW1.7.
 - Entry in the alarm buffer.
- General properties of faults and alarms
 - Triggering on selected messages possible.
 - Contain the component number for identifying the affected SINAMICS component.
 - Contain diagnostic information on the relevant message.

Message class

For each message, specifies the associated message class with the following structure:

Text of the message class (number according to PROFIdrive)

The message classes that are available are shown in the table below, which provides the text of the message class, their number according to PROFIdrive, and a brief help text regarding the cause and remedy.

Text of the message class (number according to PROFIdrive)	Cause and remedy
Hardware/software errors (1)	A hardware or software malfunction was detected. Carry out a POWER ON for the relevant component. If it occurs again, contact the hotline.
Line fault (2)	A line supply fault has occurred (phase failure, voltage level ...). Check the line supply and fuses. Check the supply voltage. Check the wiring.
Supply voltage fault (3)	An electronics supply voltage fault (48 V, 24 V, 5 V ...) was detected. Check the wiring. Check the voltage level.
DC link overvoltage (4)	The DC link voltage has assumed an inadmissibly high value. Check the dimensioning of the system (line supply, reactor, voltages). Check the infeed settings.
Power electronics fault (5)	An impermissible operating state of the power electronics was detected (overcurrent, overtemperature, IGBT failure ...). Check compliance with the permissible load cycles. Check the ambient temperatures (fan).
Overtemperature of the electronic component (6)	The temperature in the component has exceeded the highest permissible limit. Check the ambient temperature/control cabinet ventilation.
Ground fault/inter-phase short-circuit detected (7)	A ground fault/inter-phase short-circuit was detected in the power cables or in the motor windings. Check the power cables (connection). Check the motor.
Motor overload (8)	The motor was operated outside the permissible limits (temperature, current, torque ...). Check the load cycles and set limits. Check the ambient temperature/motor cooling.
Communication to the higher-level controller faulted (9)	The communication to the higher-level controller (internal coupling, PROFINET ...) is faulted or interrupted. Check the state of the higher-level controller. Check the communication connection/wiring. Check the bus configuration/cycles.
Safety monitoring channel has detected an error (10)	A safe operation monitoring function has detected an error.
Actual position/speed value incorrect or not available (11)	An illegal signal state was detected while evaluating the encoder signals (track signals, zero marks, absolute values ...). Check the encoder/state of the encoder signals. Observe the maximum permissible frequencies.
Internal communication faulted (12)	The internal communication between the SINAMICS components is faulted or interrupted. Ensure an EMC compliant installation. Observe the maximum permissible quantity structures/cycles.
Infeed fault (13)	The infeed is faulty or has failed. Check the infeed and its environment (line supply, filters, reactors, fuses ...). Check the infeed control.
Braking controller/Braking Module faulted (14)	The internal or external Braking Module is faulted or overloaded (temperature). Check the connection/state of the Braking Module. Comply with the permissible number of braking operations and their duration.
Line filter fault (15)	The line filter monitoring has detected an excessively high temperature or another impermissible state. Check the temperature/temperature monitoring. Check the configuration to ensure that it is permissible (filter type, infeed, thresholds).

Text of the message class (number according to PROFIdrive)	Cause and remedy
External measured value/signal state outside of the permissible range (16)	A measured value/signal state read in via the input area (digital/temperature) has assumed an impermissible value/state. Identify and check the relevant signal. Check the set thresholds.
Application/technological function faulty (17)	The application/technological function has exceeded a (set) limit (position, velocity, torque ...). Identify and check the relevant limit. Check the setpoint specification of the higher-level controller.
Error in the parameterization/configuration/commissioning procedure (18)	An error was identified in the parameterization or in a commissioning procedure, or the parameterization does not match the actual device configuration. Determine the precise cause of the fault using the commissioning tool. Adapt the parameterization or device configuration.
General drive fault (19)	Group fault. Determine the precise cause of the fault using the commissioning tool.
Auxiliary unit fault (20)	The monitoring of an auxiliary unit (incoming transformer, cooling unit ...) has detected an illegal state. Determine the exact cause of the fault and check the relevant device.

Differences between faults and alarms

The differences between faults and alarms are shown as follows:

Type	BOP display (example)		Status indicator		Reaction	Acknowledgement
			RDY	COM		
Fault		Single fault	Slow flashing in red	-	<ul style="list-style-type: none"> NONE: no reaction OFF1: servo motor ramps down OFF2: servo motor coasts down OFF3: servo motor stops quickly (emergency stop) ENOCDER: Encoder fault causes OFF2. 	<ul style="list-style-type: none"> POWER ON: re-power on the servo drive to clear a fault after eliminating its cause. IMMEDIATELY: the fault disappears immediately after eliminating its cause. PULSE INHIBIT: The fault can only be acknowledged with a pulse inhibit. The same options are available for acknowledging as described under acknowledgment with IMMEDIATELY.
		The first fault in the case of multiple faults				
		Non-first fault in the case of multiple faults				
Alarm		Single alarm	Slow flashing in red	-	<ul style="list-style-type: none"> NONE: no reaction 	Self-acknowledgement
		The first alarm in the case of multiple alarms				
		Non-first alarm in the case of multiple alarms				

NOTICE

Faults are displayed in prior to alarms

If both faults and alarms occur, faults are displayed prior to alarms. Alarms are displayed only after all faults have been acknowledged.

BOP operations for faults and alarms

To view faults or alarms, proceed as follows:

- Faults



- Alarms

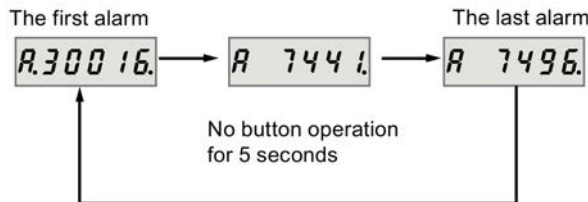

To exit from fault or alarm display, proceed as follows:

- Faults

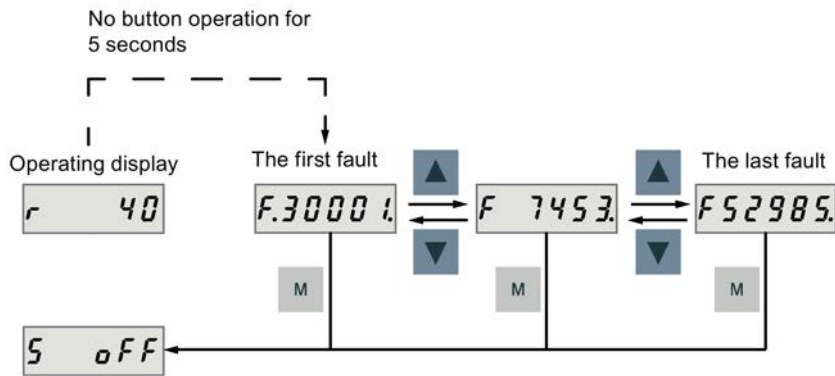

- Alarms

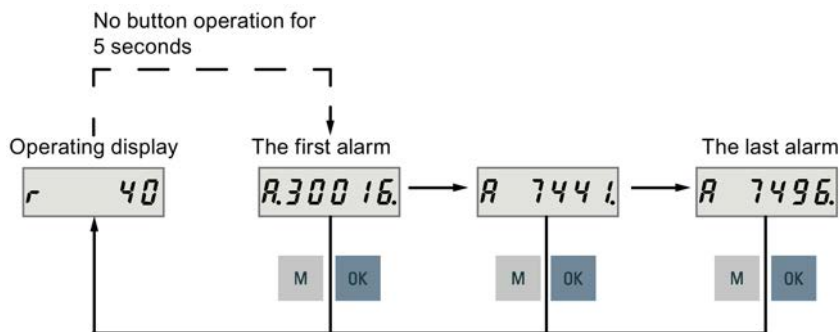

To acknowledge faults, proceed as follows:

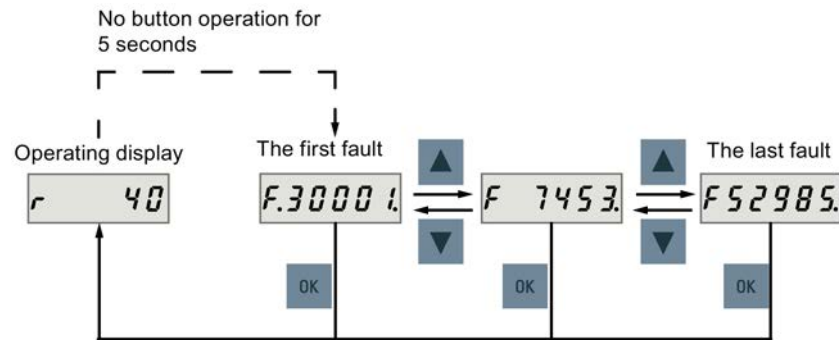

Note

- If you do not eliminate the cause(s) of the fault, it can appear again after no button operation for five seconds. Make sure that you have eliminated the cause(s) of the fault.
- You can acknowledge faults using RESET signal. For details of the signal, refer to DIs (Page 103).

12.2 List of faults and alarms

This section lists only common faults and alarms. To view the detailed information of all faults and alarms, call the online help for an active fault/alarm in the SINAMICS V-ASSISTANT engineering tool.

Fault list

Fault	Cause	Remedy
F1000: Internal software error Message class: Hardware/software error (1) Reaction: OFF2 Acknowledgement: POWER ON	An internal software error has occurred.	<ul style="list-style-type: none"> • Evaluate fault buffer. • Carry out a POWER ON (power off/on) for all components. • Upgrade firmware to later version. • Contact the Hotline. • Replace the Control Unit.
F1001: FloatingPoint exception Message class: Hardware/software error (1) Reaction: OFF2 Acknowledgement: POWER ON	An exception occurred during an operation with the FloatingPoint data type.	<ul style="list-style-type: none"> • Carry out a POWER ON (power off/on) for all components. • Upgrade firmware to the latest version. • Contact the Hotline.

12.2 List of faults and alarms

Fault	Cause	Remedy
<p>F1002: Internal software error Message class: Hardware/software error (1) Reaction: OFF2 Acknowledgement: IMMEDIATELY</p>	<p>An internal software error has occurred.</p>	<ul style="list-style-type: none"> • Carry out a POWER ON (power off/on) for all components. • Upgrade firmware to the latest version. • Contact the Hotline.
<p>F1003: Acknowledgement delay when accessing the memory Message class: Hardware/software error (1) Reaction: OFF2 Acknowledgement: IMMEDIATELY</p>	<p>A memory area was accessed that does not return a "READY".</p>	<ul style="list-style-type: none"> • Carry out a POWER ON (power off/on). • Contact the Hotline.
<p>F1015: Internal software error Message class: Hardware/software error (1) Reaction: OFF2 Acknowledgement: POWER ON</p>	<p>An internal software error has occurred.</p>	<ul style="list-style-type: none"> • Carry out a POWER ON (power off/on) for all components. • Upgrade firmware to the latest version. • Contact the Hotline.
<p>F1018: Booting has been interrupted several times Message class: Hardware/software error (1) Reaction: NONE Acknowledgement: POWER ON</p>	<p>Module booting was interrupted several times. As a consequence, the module boots with the factory setting. Possible reasons for booting being interrupted:</p> <ul style="list-style-type: none"> • Power supply interrupted. • CPU crashed. • Parameterization invalid. <p>After this fault is output, then the module is booted with the factory settings.</p>	<ul style="list-style-type: none"> • Carry out a POWER ON (power off/on). After switching on, the module reboots from the valid parameterization (if available). • Restore the valid parameterization <p>Examples:</p> <ul style="list-style-type: none"> • Carry out a first commissioning, save, carry out a POWER ON (switch-off/switch-on). • Load another valid parameter backup (e.g. from the memory card), save, carry out a POWER ON (switch-off/switch-on). <p>Note: If the fault situation is repeated, then this fault is again output after several interrupted boots.</p>
<p>F1030: Sign-of-life failure for master control Message class: Communication to the higher-level controller faulted (9) Reaction: OFF3 Acknowledgement: IMMEDIATELY</p>	<p>For active PC master control, no sign-of-life was received within the monitoring time.</p>	<p>Contact the Hotline.</p>

Fault	Cause	Remedy
<p>F1611: SI CU: Defect detected</p> <p>Message class: Safety monitoring channel has identified an error (10)</p> <p>Reaction: OFF2</p> <p>Acknowledgement: IMMEDIATELY</p>	<p>The drive-integrated "Safety Integrated" (SI) function on the Control Unit (CU) has detected an error and initiated an STO.</p>	<ul style="list-style-type: none"> • Make sure that the high level duration of the input pulse is larger than 500 ms. • Carry out a POWER ON (power off/on) for all components. • Upgrade software. • Replace the Control Unit.
<p>F1910: Fieldbus: setpoint timeout</p> <p>Message class: Communication to the higher-level controller faulted (9)</p> <p>Reaction: OFF3</p> <p>Acknowledgement: IMMEDIATELY</p>	<p>The reception of setpoints from the fieldbus interface (Modbus/USS) has been interrupted.</p> <ul style="list-style-type: none"> • Bus connection interrupted. • Controller switched off. • Controller set into the STOP state. 	<p>Restore the bus connection and set the controller to RUN.</p>
<p>F1911: PROFIdrive: Clock cycle synchronous operation clock cycle failure</p> <p>Message class: Communication to the higher-level controller faulted (9)</p> <p>Reaction: OFF1</p> <p>Acknowledgement: IMMEDIATELY</p>	<p>The global control telegram to synchronize the clock cycles has failed - for several DP clock cycles or has violated the time grid specified in the parameterizing telegram over several consecutive DP clock cycles (refer to the bus cycle time, Tdp and Tplw).</p>	<ul style="list-style-type: none"> • Check the physical bus configuration (cable, connector, terminating resistor, shielding, etc.). • Check whether communication was briefly or permanently interrupted. • Check the bus and controller for utilization level (e.g. bus cycle time Tdp was set too short).
<p>F1912: PROFIdrive: Clock cycle synchronous operation sign-of-life failure</p> <p>Message class: Communication to the higher-level controller faulted (9)</p> <p>Reaction: OFF1</p> <p>Acknowledgement: IMMEDIATELY</p>	<p>The maximum permissible number of errors in the controller sign-of-life (clock synchronous operation) has been exceeded in cyclic operation.</p>	<ul style="list-style-type: none"> • Physically check the bus (cables, connectors, terminating resistor, shielding, etc). • Correct the interconnection of the controller sign-of-life. • Check whether the controller correctly sends the sign-of-life (e.g. create a trace with STW2.12...STW2.15 and trigger signal ZSW1.3). • Check the permissible telegram failure rate (p0925). • Check the bus and controller for utilization level (e.g. bus cycle time was set too short).

12.2 List of faults and alarms

Fault	Cause	Remedy
<p>F7011: Motor overtemperature Message class: Motor overload (8) Reaction: OFF2 Acknowledgement: IMMEDIATELY</p>	<ul style="list-style-type: none"> • Motor overloaded • Motor surrounding temperature too high • Wire breakage or sensor not connected • Motor temperature model incorrectly parameterized 	<ul style="list-style-type: none"> • Reduce the motor load. • Check the surrounding temperature and the motor ventilation. • Check the wiring and the connection. • Check the motor temperature model parameters.
<p>F7085: Open-loop/closed-loop control parameters changed Message class: Error in the parameterization/configuration/commissioning procedure (18) Reaction: NONE Acknowledgement: IMMEDIATELY</p>	<p>Open-loop/closed-loop control parameters have had to be changed for the following reasons:</p> <ul style="list-style-type: none"> • As a result of other parameters, they have exceeded the dynamic limits. • They cannot be used due to the fact that the hardware detected not having certain features. 	<p>It is not necessary to change the parameters as they have already been correctly limited.</p>
<p>F7090: Drive: Upper torque limit less than the lower torque limit Message class: Error in the parameterization/configuration/commissioning procedure (18) Reaction: OFF2 Acknowledgement: IMMEDIATELY</p>	<p>The upper torque limit is lower than the lower torque limit.</p>	<p>The upper torque limit (p29050) must be \geq lower torque limit (p29051)</p>
<p>F7093: Drive: Test signal error Message class: Error in the parameterization/configuration/commissioning procedure (18) Reaction: OFF3 Acknowledgement: IMMEDIATELY</p>	<p>The limit rotation of the motor (p29027) is inappropriate.</p>	<p>Modify the value of parameter p29027.</p>
<p>F7220: Drive: Master control by PLC missing Message class: Communication to the higher-level controller faulted (9) Reaction: OFF1 Acknowledgement: IMMEDIATELY</p>	<p>The "master control by PLC" signal was missing in operation.</p> <ul style="list-style-type: none"> • Input for "master control by PLC" is incorrect. • The higher-level control has withdrawn the "master control by PLC" signal. • Data transfer via the fieldbus (master/drive) was interrupted. 	<ul style="list-style-type: none"> • Check the input for "master control by PLC". • Check the "master control by PLC" signal and, if required, switch in. • Check the data transfer via the fieldbus (master/drive).

Fault	Cause	Remedy
F7403: Lower DC link voltage threshold reached Message class: Infeed faulted (13) Reaction: OFF1 Acknowledgement: IMMEDIATELY	The DC link voltage monitoring is active and the lower DC link voltage threshold was reached in the "Operation" state.	<ul style="list-style-type: none"> • Check the line supply voltage. • Check the infeed. • Reduce the lower DC link threshold. • Switch out (disable) the DC link voltage monitoring.
F7404: Upper DC link voltage threshold reached Message class: DC link over-voltage (4) Reaction: OFF2 Acknowledgement: IMMEDIATELY	The DC link voltage monitoring is active and the upper DC link voltage threshold was reached in the "Operation" state.	<ul style="list-style-type: none"> • Check the line supply voltage. • Check the infeed module or the brake module. • Increase the upper DC link voltage threshold. • Switch out (disable) the DC link voltage monitoring.
F7410: Current controller output limited Message class: Application/technological function faulty (17) Reaction: OFF2 Acknowledgement: IMMEDIATELY	The condition " $I_{act} = 0$ and $U_q_set_1$ longer than 16 ms at its limit" is present and can be caused by the following: <ul style="list-style-type: none"> • Motor not connected or motor contactor open. • No DC link voltage present. • Motor Module defective. 	<ul style="list-style-type: none"> • Connect the motor or check the motor contactor. • Check the DC link voltage. • Check the Motor Module.
F7412: Commutation angle incorrect (motor model) Message class: Actual position/speed value incorrect or not available (11) Reaction: ENCODER Acknowledgement: IMMEDIATELY	An incorrect commutation angle was detected that can result in a positive coupling in the speed controller. Possible causes: <ul style="list-style-type: none"> • The motor encoder is incorrectly adjusted with respect to the magnet position. • The motor encoder is damaged. • Data to calculate the motor model has been incorrectly set. • Pole position identification might have calculated an incorrect value when activated. • The motor encoder speed signal is faulted. • The control loop is instable due to incorrect parameterization. 	<ul style="list-style-type: none"> • If the encoder mounting was changed, re-adjust the encoder. • Replace the defective motor encoder. • Correctly set the motor stator resistance, cable resistance and motor-stator leakage inductance. Calculate the cable resistance from the cross-section and length, check the inductance and stator resistance using the motor data sheet, measure the stator resistance, e.g. using a multimeter - and if required, again identify the values using the stationary motor data identification. • With pole position identification activated, check the procedure for pole position identification and force a new pole position identification procedure by means of de-selection followed by selection.
F7420: Drive: Current set-point filter natural frequency > Shannon frequency Message class: Error in the parameterization/configuration/commissioning procedure (18)	One of the filter natural frequencies is greater than the Shannon frequency.	<ul style="list-style-type: none"> • Reduce the numerator or denominator natural frequency of the current setpoint filter involved. • Switch out the filter involved (p1656).

Fault	Cause	Remedy
<p>F7442: LR: multi-turn does not match the modulo range Message class: Error in the parameterization/configuration/commissioning procedure (18) Reaction: OFF1 (OFF2, OFF3) Acknowledgement: IMMEDIATELY</p>	<p>The ratio between the multi-turn resolution and the modulo range (p29246) is not an integer number. This results in the adjustment being set back, as the position actual value cannot be reproduced after power-off/power-on.</p>	<p>Make the ratio between the multi-turn resolution and the modulo range an integer number. The ratio v is calculated as follows:</p> <ul style="list-style-type: none"> • Motor encoder without position tracking (p29243 = 0): <ul style="list-style-type: none"> – For multi-turn encoders: $v = (4096 * p29247 * p29248) / (p29249 * p29246)$ – For single-turn encoders: $v = (p29247 * p29248) / (p29249 * p29246)$ • Motor encoder with position tracking (p29243 = 1): $v = (p29244 * 29247) / p29246$
<p>F7443: Reference point coordinate not in the permissible range Message class: Error in the parameterization/configuration/commissioning procedure (18) Reaction: OFF1 (OFF2, OFF3) Acknowledgement: IMMEDIATELY</p>	<p>The reference point coordinate received when adjusting the encoder via connector input p2599 lies outside the half of the encoder range and cannot be set as actual axis position. Fault value (r0949, interpret decimal): Maximum permissible value for the reference point coordinate.</p>	<p>Set the reference point coordinate to a lower value than specified in the fault value. See also: p2599 (EPOS reference point coordinate value). For a motor with an absolute encoder, the maximum permissible encoder range is calculated by the following formula:</p> <ul style="list-style-type: none"> • For multi-turn encoders: $(4096 * p29247) / 2$ • For single-turn encoders: $p29247 / 2$
<p>F7447: Load gear: Position tracking, maximum actual value exceeded Message class: Application/technological function faulted (17) Reaction: NONE Acknowledgement: IMMEDIATELY</p>	<p>When the position tracking of the load gear is configured, the drive/encoder (motor encoder) identifies a maximum possible absolute position actual that can no longer be represented within 32 bits. Maximum value: encoder resolution (2^{20} or 2^{21}) \times p29244</p>	<p>Reduce the multi-turn resolution (p29244).</p>
<p>F7449: Load gear: Position tracking actual position outside tolerance window Message class: Application/technological function faulted (17) Reaction: OFF1 Acknowledgement: IMMEDIATELY</p>	<p>When switched off, the currently effective motor encoder was moved through a distance greater than was parameterized in the tolerance window. It is possible that there is no longer any reference between the mechanical system and encoder. Fault value (r0949, interpret decimal): Deviation (difference) to the last encoder position in increments of the absolute value after the measuring gear - if one is being used. The sign designates the traversing direction. Note: The deviation (difference) window is pre-assigned quarter of the encoder range.</p>	<p>Reactivate the position tracking function (set p29243 = 1 \rightarrow 0 \rightarrow 1). Then the fault is acknowledged and, if necessary, adjust the encoder encoder (ABS).</p>

Fault	Cause	Remedy
<p>F7450: Standstill monitoring has responded</p> <p>Message class: Application/technological function faulty (17)</p> <p>Reaction: OFF1</p> <p>Acknowledgement: IMMEDIATELY</p>	<p>After the standstill monitoring time expired, the drive left the standstill window.</p> <ul style="list-style-type: none"> • Position loop gain too low. • Position loop gain too high (instability/oscillation). • Mechanical overload. • Connecting cable, motor/drive converter incorrect (phase missing, interchange). • Tracking mode is not activated with POS_STW.0 (telegram 110) or POS_STW2.0 (telegram 111). 	<p>Check the causes and resolve.</p>
<p>F7451: Position monitoring has responded</p> <p>Message class: Application/technological function faulty (17)</p> <p>Reaction: OFF1</p> <p>Acknowledgement: IMMEDIATELY</p>	<p>When the position monitoring time (p2545) expired, the drive had still not reached the positioning window (p2544).</p> <ul style="list-style-type: none"> • Positioning window parameterized too small (p2544). • Position monitoring time parameterized too short (p2545). • Position loop gain is too low. • Position loop gain is too high (instability/oscillation). • Drive mechanically locked. 	<p>Check the causes and resolve.</p>
<p>F7452: Following error too high</p> <p>Message class: Application/technological function faulty (17)</p> <p>Reaction: OFF1</p> <p>Acknowledgement: IMMEDIATELY</p>	<p>The difference between the position setpoint and position actual value (following error dynamic model) is greater than the tolerance (p2546).</p> <ul style="list-style-type: none"> • The value of p2546 is too small. • The gain of position loop is too small. • The drive torque or accelerating capacity exceeded. • Position measuring system fault. • Position control sense incorrect. • Mechanical system locked. • Excessively high traversing velocity or excessively high position reference value (setpoint) differences. 	<p>Check the causes and resolve.</p>
<p>F7453: Position actual value preprocessing error</p> <p>Message class: Application/technological function faulty (17)</p> <p>Reaction: OFF2</p> <p>Acknowledgement: IMMEDIATELY</p>	<p>An error has occurred during the position actual value preprocessing.</p>	<p>Check the encoder for the position actual value preprocessing.</p>

12.2 List of faults and alarms

Fault	Cause	Remedy
<p>F7458: EPOS: Reference cam not found Message class: Application/technological function faulty (17) Reaction: OFF1 (OFF2, OFF3) Acknowledgement: IMMEDIATELY</p>	<p>After starting the search for reference, the axis moved through the maximum permissible distance to search for the reference cam without actually finding the reference cam.</p>	<ul style="list-style-type: none"> • Check the "reference cam" input. • Check the maximum permissible distance to the reference cam (p2606). <p>See also: p2606 (EPOS search for reference reference cam maximum distance)</p>
<p>F7459: Zero mark not detected Message class: Application/technological function faulty (17) Reaction: OFF1 Acknowledgement: IMMEDIATELY</p>	<p>After leaving the reference cam, the axis has traversed the maximum permissible distance (p2609) between the reference cam and the zero mark without finding the zero mark.</p>	<ul style="list-style-type: none"> • Check the encoder regarding zero mark. • Check the maximum permissible distance between the reference cam and zero mark (p2609). • Use an external encoder zero mark (equivalent zero mark). <p>See also: p2609 (EPOS search for reference max distance ref cam and zero mark)</p>
<p>F7460: EPOS: End of reference cam not found Message class: Application/technological function faulty (17) Reaction: OFF1 (OFF2, OFF3) Acknowledgement: IMMEDIATELY</p>	<p>During the search for reference, when the axis reached the zero mark it also reached the end of the traversing range without detecting an edge at the binector input "reference cam". Maximum traversing range: -2147483648 [LU] ... -2147483647 [LU]</p>	<ul style="list-style-type: none"> • Check the "reference cam" input. • Repeat the search for reference.
<p>F7464: EPOS: Traversing block is inconsistent Message class: Error in the parameterization/configuration/commissioning procedure (18) Reaction: OFF1 (OFF2, OFF3) Acknowledgement: IMMEDIATELY</p>	<p>The traversing block does not contain valid information. Alarm value: Number of the traversing block with invalid information.</p>	<p>Check the traversing block and where relevant, take into consideration alarms that are present.</p>
<p>F7475: EPOS: Target position < start of traversing range Message class: Error in the parameterization/configuration/commissioning procedure (18) Reaction: OFF1 (OFF2, OFF3) Acknowledgement: IMMEDIATELY</p>	<p>The target position for relative traversing lies outside the traversing range.</p>	<p>Correct the target position.</p>

Fault	Cause	Remedy
<p>F7476: EPOS: Target position > end of the traversing range</p> <p>Message class: Error in the parameterization/configuration/commissioning procedure (18)</p> <p>Reaction: OFF1 (OFF2, OFF3)</p> <p>Acknowledgement: IMMEDIATELY</p>	<p>The target position for relative traversing lies outside the traversing range.</p>	<p>Correct the target position.</p>
<p>F7481: EPOS: Axis position < software limit switch minus</p> <p>Message class: Application/technological function faulty (17)</p> <p>Reaction: OFF1 (OFF2, OFF3)</p> <p>Acknowledgement: IMMEDIATELY</p>	<p>The actual position of the axis is less than the position of the software limit switch minus.</p>	<ul style="list-style-type: none"> • Correct the target position. • Change software limit switch minus (CI: p2580). <p>See also: p2580 (EPOS software limit switch minus), p2582 (EPOS software limit switch activation)</p>
<p>F7482: EPOS: Axis position > software limit switch plus</p> <p>Message class: Application/technological function faulty (17)</p> <p>Reaction: OFF1 (OFF2, OFF3)</p> <p>Acknowledgement: IMMEDIATELY</p>	<p>The actual position of the axis is greater than the position of the software limit switch plus.</p>	<ul style="list-style-type: none"> • Correct the target position. • Change software limit switch plus (CI: p2581). <p>See also: p2580 (EPOS software limit switch minus), p2582 (EPOS software limit switch activation)</p>
<p>F7484: EPOS: Fixed stop outside the monitoring window</p> <p>Message class: Application/technological function faulty (17)</p> <p>Reaction: OFF1 (OFF2, OFF3)</p> <p>Acknowledgement: IMMEDIATELY</p>	<p>In the "fixed stop reached" state, the axis has moved outside the defined monitoring window (p2635).</p>	<ul style="list-style-type: none"> • Check the monitoring window (p2635). • Check the mechanical system.
<p>F7485: EPOS: Fixed stop not reached</p> <p>Message class: Application/technological function faulty (17)</p> <p>Reaction: OFF1 (OFF2, OFF3)</p> <p>Acknowledgement: IMMEDIATELY</p>	<p>In a traversing block with the task FIXED STOP, the end position was reached without detecting a fixed stop.</p>	<ul style="list-style-type: none"> • Check the traversing block and locate the target position further into the workpiece. • Check the "fixed stop reached" control signal. • If required, reduce the maximum following error window to detect the fixed stop (p2634).

12.2 List of faults and alarms

Fault	Cause	Remedy
<p>F7488: EPOS: Relative positioning not possible Message class: Application/technological function faulty (17) Reaction: OFF1 (OFF2, OFF3) Acknowledgement: IMMEDIATELY</p>	<p>In the mode "direct setpoint input/MDI", for continuous transfer relative positioning was selected.</p>	<p>Check the control.</p>
<p>F7490: Enable signal withdrawn while traversing Message class: Application/technological function faulty (17) Reaction: OFF1 Acknowledgement: IMMEDIATELY</p>	<ul style="list-style-type: none"> • For a standard assignment, another fault may have occurred as a result of withdrawing the enable signals. • The drive is in the "switching on inhibited" state (for a standard assignment). 	<ul style="list-style-type: none"> • Set the enable signals or check the cause of the fault that first occurred and then result (for a standard assignment). • Check the assignment to enable the basic positioning function.
<p>F7491: STOP cam minus reached Message class: Application/technological function faulty (17) Reaction: OFF3 Acknowledgement: IMMEDIATELY</p>	<p>The STOP cam minus was reached. For a positive traversing direction, the STOP cam minus was reached, i.e. the wiring of the STOP cam is incorrect.</p>	<ul style="list-style-type: none"> • Leave the STOP cam minus in the positive traversing direction and return the axis to the valid traversing range. • Check the wiring of the STOP cam.
<p>F7492: STOP cam plus reached Message class: Application/technological function faulty (17) Reaction: OFF3 Acknowledgement: IMMEDIATELY</p>	<p>The STOP cam plus was reached. For a negative traversing direction, the STOP cam plus was reached, i.e. the wiring of the STOP cam is incorrect.</p>	<ul style="list-style-type: none"> • Leave the STOP cam plus in the negative traversing direction and return the axis to the valid traversing range. • Check the wiring of the STOP cam.
<p>F7493: LR: Overflow of the value range for position actual value Message class: Application/technological function faulty (17) Reaction: OFF1 (OFF2, OFF3) Acknowledgement: IMMEDIATELY</p>	<p>The value range (-2147483648 ... 2147483647) for the position actual value representation was exceeded. When the overflow occurs, the "referenced" or "adjustment absolute measuring system" status is reset.</p> <ul style="list-style-type: none"> • The position actual value (r2521) has exceeded the value range. • The encoder position actual value has exceeded the value range. • The maximum encoder value times the factor to convert the absolute position from increments to length units (LU) has exceeded the value range for displaying the position actual value. 	<p>If required, reduce the traversing range or position resolution p29247. Note for case = 3: If the value for the maximum possible absolute position (LU) is greater than 4294967296, then it is not possible to make an adjustment due to an overflow. For rotary encoders, the maximum possible absolute position (LU) is calculated as follows: Motor encoder with position tracking: EPOS: $p29247 * p29244$ Motor encoder without position tracking:</p> <ul style="list-style-type: none"> • For multi-turn encoders: EPOS: $p29247 * p29248 * 4096 / p29249$ • For single-turn encoders: EPOS: $p29247 * p29248 / p29249$

Fault	Cause	Remedy
<p>F7575: Drive: Motor encoder not ready</p> <p>Message class: Actual position/speed value incorrect or not available (11)</p> <p>Reaction: OFF2</p> <p>Acknowledgement: IMMEDIATELY</p>	<p>The motor encoder signals that it is not ready.</p> <ul style="list-style-type: none"> • Initialization of motor encoder was unsuccessful. • The function "parking encoder" is active (encoder control word G1_STW.14 = 1). 	<p>Evaluate other queued faults via motor encoder.</p>
<p>F7599: Encoder 1: Adjustment not possible</p> <p>Message class: Error in the parameterization/configuration/commissioning procedure (18)</p> <p>Reaction: OFF1 (NONE, OFF2, OFF3)</p> <p>Acknowledgement: IMMEDIATELY</p>	<p>The maximum encoder value times the factor to convert the absolute position from increments to length units (LU) has exceeded the value range (-2147483648 ... 2147483647) for displaying the position actual value.</p>	<p>If the value for the maximum possible absolute position (LU) is greater than 4294967296, then it is not possible to make an adjustment due to an overflow.</p> <p>For rotary encoders, the maximum possible absolute position (LU) is calculated as follows:</p> <p>Motor encoder with position tracking: EPOS: p29247 * p29244</p> <p>Motor encoder without position tracking:</p> <ul style="list-style-type: none"> • For multiturn encoders: EPOS: p29247 * p29248 * 4096 / p29249 • For singleturn encoders: EPOS: p29247 * p29248 / p29249
<p>F7800 Drive: No power unit present</p> <p>Message class: Error in the parameterization/configuration/commissioning procedure (18)</p> <p>Reaction: NONE</p> <p>Acknowledgement: IMMEDIATELY</p>	<p>The power unit parameters cannot be read or no parameters are stored in the power unit.</p>	<ul style="list-style-type: none"> • Carry out a POWER ON (power off/on) for all components. • Change the module.
<p>F7801: Motor overcurrent</p> <p>Message class: Motor overload (8)</p> <p>Reaction: OFF2</p> <p>Acknowledgement: IMMEDIATELY</p>	<p>The permissible motor limit current was exceeded.</p> <ul style="list-style-type: none"> • Effective current limit set too low. • Current controller not correctly set. • Motor was braked with an excessively high stall torque correction factor. • Up ramp was set too short or the load is too high. • Short-circuit in the motor cable or ground fault. • Motor current does not match the current of Motor Module. 	<ul style="list-style-type: none"> • Reduce the stall torque correction factor. • Increase the up ramp or reduce the load. • Check the motor and motor cables for short-circuit and ground fault. • Check the Motor Module and motor combination.

12.2 List of faults and alarms

Fault	Cause	Remedy
<p>F7802: Infeed or power unit not ready Message class: Infeed faulted (13) Reaction: OFF2 Acknowledgement: IMMEDIATELY</p>	<p>After an internal power-on command, the infeed or drive does not signal ready because of one of the following reasons:</p> <ul style="list-style-type: none"> • Monitoring time is too short. • DC link voltage is not present. • Associated infeed or drive of the signaling component is defective. 	<ul style="list-style-type: none"> • Ensure that there is a DC link voltage. Check the DC link busbar. Enable the infeed. • Replace the associated infeed or drive of the signaling component.
<p>F7815: Power unit has been changed Message class: Error in the parameterization/configuration/commissioning procedure (18) Reaction: NONE Acknowledgement: IMMEDIATELY</p>	<p>The code number of the actual power unit does not match the saved number.</p>	<p>Connect the original power unit and power up the Control Unit again (POWER ON).</p>
<p>F7900: Motor blocked/speed controller at its limit Message class: Application/technological function faulty (17) Reaction: OFF2 Acknowledgement: IMMEDIATELY</p>	<p>The servo motor has been operating at the torque limit longer than 1s and below the speed threshold of 120 rpm . This signal can also be initiated if the speed actual value is oscillating and the speed controller output repeatedly goes to its limit.</p>	<ul style="list-style-type: none"> • Check whether the servo motor can rotate freely or not. • Check the torque limit. • Check the inversion of the actual value. • Check the motor encoder connection. • Check the encoder pulse number.
<p>F7901: Motor overspeed Message class: Application/technological function faulty (17) Reaction: OFF2 Acknowledgement: IMMEDIATELY</p>	<p>The maximumly permissible speed has been exceeded.</p>	<ul style="list-style-type: none"> • Check and correct the maximum speed (p1082). • Check if there are any peaks of actual speed. If the value of the peak is especially large, contact the hotline.
<p>F7995: Motor identification failure Message class: Error in the parameterization/configuration/commissioning procedure (18) Reaction: OFF2 Acknowledgement: IMMEDIATELY</p>	<p>For incremental motor, needs pole position identification when the motor is servo on for the first time. If the motor already in run (i.e. by external force) position identification may failure.</p>	<p>Stop the motor before servo on.</p>
<p>F8501: PROFIdrive: Setpoint timeout Message class: Communication to the higher-level controller faulted (9) Reaction: OFF3 Acknowledgement: IMMEDIATELY</p>	<p>The reception of setpoints from the PROFINET has been interrupted.</p> <ul style="list-style-type: none"> • PROFINET connection interrupted. • Controller switched off. • Controller set into the STOP state. • PROFINET defective. 	<p>Restore the PROFINET connection and set the controller to RUN.</p>

Fault	Cause	Remedy
<p>F30001: Power unit: Overcurrent</p> <p>Message class: Power electronics faulted (5)</p> <p>Reaction: OFF2</p> <p>Acknowledgement: IMMEDIATELY</p>	<p>The power unit has detected an overcurrent condition.</p> <ul style="list-style-type: none"> • Closed-loop control is incorrectly parameterized. • Controller parameters are not proper. • Motor has a short-circuit or fault to ground (frame). • Power cables are not correctly connected. • Power cables exceed the maximum permissible length. • Power unit defective. • Line phase interrupted. 	<ul style="list-style-type: none"> • Check the motor data - if required, carry out commissioning. • Modify speed loop Kp (p29120), position loop Kv (p29110). • Check the motor circuit configuration (star-delta). • Check the power cable connections. • Check the power cables for short-circuit or ground fault. • Check the length of the power cables. • Replace power unit. • Check the line supply phases. • Check the external braking resistor connection.
<p>F30002: DC link voltage, overvoltage</p> <p>Message class: DC link overvoltage (4)</p> <p>Reaction: OFF2</p> <p>Acknowledgement: IMMEDIATELY</p>	<p>The power unit has detected overvoltage in the DC link.</p> <ul style="list-style-type: none"> • Motor regenerates too much energy. • Device connection voltage too high. • Line phase interrupted. 	<ul style="list-style-type: none"> • Increase the ramp-down time. • Activate the DC link voltage controller. • Use a braking resistor. • Increase the current limit of the infeed or use a larger module. • Check the device supply voltage. • Check the line supply phases.
<p>F30003: DC link voltage, undervoltage</p> <p>Message class: Infeed faulted (13)</p> <p>Reaction: OFF2</p> <p>Acknowledgement: IMMEDIATELY</p>	<p>The power unit has detected an undervoltage condition in the DC link.</p> <ul style="list-style-type: none"> • Line supply failure • Line supply voltage below the permissible value. • Line supply infeed failed or interrupted. • Line phase interrupted. 	<ul style="list-style-type: none"> • Check the line supply voltage • Check the line supply infeed and observe the fault messages relating to it (if there are any) • Check the line supply phases. • Check the line supply voltage setting.
<p>F30004: Drive heat sink overtemperature</p> <p>Message class: Power electronics faulted (5)</p> <p>Reaction: OFF2</p> <p>Acknowledgement: IMMEDIATELY</p>	<p>The temperature of the power unit heat sink has exceeded the permissible limit value.</p> <ul style="list-style-type: none"> • Insufficient cooling, fan failure. • Overload. • Surrounding temperature too high. • Pulse frequency too high. 	<ul style="list-style-type: none"> • Check whether the fan is running. • Check the fan elements. • Check whether the surrounding temperature is in the permissible range. • Check the motor load. • Reduce the pulse frequency if this is higher than the rated pulse frequency.
<p>F30005: Power unit: Overload I²t</p> <p>Message class: Power electronics faulted (5)</p> <p>Reaction: OFF2</p> <p>Acknowledgement: IMMEDIATELY</p>	<p>The power unit was overloaded.</p> <ul style="list-style-type: none"> • The permissible rated power unit current was exceeded for an inadmissibly long time. • The permissible load duty cycle was not maintained. 	<ul style="list-style-type: none"> • Reduce the continuous load. • Adapt the load duty cycle. • Check the motor and power unit rated currents.

Fault	Cause	Remedy
<p>F30011: Line phase failure in main circuit Message class: Network fault (2) Reaction: OFF2 Acknowledgement: IMMEDIATELY</p>	<p>At the power unit, the DC link voltage ripple has exceeded the permissible limit value. Possible causes:</p> <ul style="list-style-type: none"> • A line phase has failed. • The 3 line phases are inadmissibly unsymmetrical. • The fuse of a phase of a main circuit has ruptured. • A motor phase has failed. 	<ul style="list-style-type: none"> • Check the main circuit fuses. • Check whether a single-phase load is distorting the line voltages. • Check the motor feeder cables.
<p>F30015: Phase failure motor cable Message class: Application/technological function faulty (17) Reaction: OFF2 Acknowledgement: IMMEDIATELY</p>	<p>A phase failure in the motor feeder cable was detected. The signal can also be output in the following case: The motor is correctly connected, however the closed-speed control is instable and therefore an oscillating torque is generated.</p>	<ul style="list-style-type: none"> • Check the motor feeder cables. • Check the speed controller settings.
<p>F30021: Ground fault Message class: Ground fault/inter-phase short-circuit detected (7) Reaction: OFF2 Acknowledgement: IMMEDIATELY</p>	<p>Power unit has detected a ground fault.</p> <ul style="list-style-type: none"> • Ground fault in the power cables. • Winding fault or ground fault at the motor. 	<ul style="list-style-type: none"> • Check the power cable connections. • Check the motor.
<p>F30027: Precharging DC link time monitoring Message class: Infeed faulted (13) Reaction: OFF2 Acknowledgement: IMMEDIATELY</p>	<ul style="list-style-type: none"> • The power unit DC link was not able to be pre-charged within the expected time. There is no line supply voltage connected. • The line contactor/line side switch has not been closed. • The line supply voltage is too low. • The pre-charging resistors are overheated as there were too many pre-charging operations per time unit • The pre-charging resistors are overheated as the DC link capacitance is too high. • The pre-charging resistors are overheated. • The pre-charging resistors are overheated as the line contactor was closed during the DC link fast discharge through the Braking Module. • The DC link has either a ground fault or a short-circuit. • The pre-charging circuit is possibly defective. 	<p>Check the line supply voltage at the input terminals.</p>

Fault	Cause	Remedy
F30036: Internal overtemperature Message class: Power electronics faulted (5) Reaction: OFF2 Acknowledgement: IMMEDIATELY	The temperature inside the drive converter has exceeded the permissible temperature limit. <ul style="list-style-type: none"> • Insufficient cooling, fan failure. • Overload. • Surrounding temperature too high. 	<ul style="list-style-type: none"> • Check whether the fan is running. • Check the fan elements. • Check whether the surrounding temperature is in the permissible range. Notice: This fault can only be acknowledged once the permissible temperature limit minus 5 K has been fallen below.
F30050: 24 V supply overvoltage Message class: Supply voltage fault (undervoltage) (3) Reaction: OFF2 Acknowledgement: POWER ON	The voltage monitor signals an overvoltage fault on the module.	<ul style="list-style-type: none"> • Check the 24 V power supply. • Replace the module if necessary.
F31100: Zero mark distance error Message class: Actual position/speed value incorrect or not available (11) Reaction: ENCODER Acknowledgement: PULSE INHIBIT	The measured zero mark distance does not correspond to the parameterized zero mark distance. For distance-coded encoders, the zero mark distance is determined from zero marks detected pairs. This means that if a zero mark is missing, depending on the pair generation, this cannot result in a fault and also has no effect in the system.	<ul style="list-style-type: none"> • Check that the encoder cables are routed in compliance with EMC. • Check the plug connections • Replace the encoder or encoder cable
F31101: Zero mark failed Message class: Actual position/speed value incorrect or not available (11) Reaction: ENCODER Acknowledgement: PULSE INHIBIT	The 1.5 x parameterized zero mark distance was exceeded.	<ul style="list-style-type: none"> • Check that the encoder cables are routed in compliance with EMC. • Check the plug connections. • Replace the encoder or encoder cable.
F31110: Serial communications error Message class: Actual position/speed value incorrect or not available (11) Reaction: ENCODER Acknowledgement: PULSE INHIBIT	Serial communication protocol transfer error between the encoder and evaluation module.	<ul style="list-style-type: none"> • Check the encoder cable and shielding connection. • Replace the encoder cable/encoder.
F31111: Encoder 1: Absolute encoder internal error Message class: Actual position/speed value incorrect or not available (11) Reaction: ENCODER Acknowledgement: PULSE INHIBIT	The absolute encoder fault word supplies fault bits that have been set.	<ul style="list-style-type: none"> • Check the encoder cable connection and make sure the cables are routed in compliance with EMC. • Check the motor temperature. • Replace the motor/encoder.

12.2 List of faults and alarms

Fault	Cause	Remedy
<p>F31112: Error bit set in the serial protocol Message class: Actual position/speed value incorrect or not available (11) Reaction: ENCODER Acknowledgement: PULSE INHIBIT</p>	<p>The encoder sends a set error bit via the serial protocol.</p>	<p>Refer to F31111.</p>
<p>F31117: Inversion error signals A/B/R Message class: Actual position/speed value incorrect or not available (11) Reaction: ENCODER Acknowledgement: PULSE INHIBIT</p>	<p>For a square-wave encoder (bipolar, double ended) signals A*, B* and R* are not inverted with respect to signals A, B and R.</p>	<ul style="list-style-type: none"> • Check the encoder and cable and the connection of them. • Does the encoder supply signals and the associated inverted signals?
<p>F31130: Zero mark and position error from the coarse synchronization Message class: Actual position/speed value incorrect or not available (11) Reaction: ENCODER Acknowledgement: PULSE INHIBIT</p>	<p>After initializing the pole position using track C/D, Hall signals or pole position identification routine, the zero mark was detected outside the permissible range. For distance-coded encoders, the test is carried out after passing 2 zero marks. Fine synchronization was not carried out.</p>	<ul style="list-style-type: none"> • Check that the encoder cables are routed in compliance with EMC. • Check the plug connections • If the Hall sensor is used as an equivalent for track C/D, check the connection. • Check the connection of track C or D. • Replace the encoder or encoder cable.
<p>F31131: Encoder 1: Deviation position incremental/absolute too large Message class: Actual position/speed value incorrect or not available (11) Reaction: ENCODER Acknowledgement: PULSE INHIBIT</p>	<ul style="list-style-type: none"> • Absolute encoder When cyclically reading the absolute position, an excessively high difference to the incremental position was detected. The absolute position that was read is rejected. Limit value for the deviation: 15 pulses (60 quadrants). • Incremental encoder When the zero is passed, a deviation in the incremental position was detected. The first zero mark passed supplies the reference point for all subsequent checks. The other zero marks must have n times the distance referred to the first zero mark. Diviation in quadrants (1 pulse = 4 quadrants). 	<ul style="list-style-type: none"> • Check that the encoder cables are routed in compliance with EMC. • Check the plug connections. • Replace the encoder or encoder cable. • Check whether the coding disk is dirty or there are strong ambient magnetic fields.

Fault	Cause	Remedy
F31150: Initialization error Message class: Error in the parameterization/configuration/commissioning procedure (18) Reaction: ENCODER Acknowledgement: PULSE INHIBIT	Encoder functionality is not operating correctly.	<ul style="list-style-type: none"> Check the encoder type used (incremental/absolute) and the encoder cable. If relevant, note additional fault messages that describe the fault in detail.
F52904: Control mode change Message class: General drive fault (19) Reaction: OFF2 Acknowledgement: POWER ON	When the control mode is changed, the drive must be saved and restarted.	Save and restart the drive.
F52980: Absolute encoder motor changed Message class: General drive fault (19) Reaction: OFF1 Acknowledgement: IMMEDIATELY	The servo motor with absolute encoder is changed. Actual motor ID is different from commissioned motor ID.	The servo motor will be automatically configured after the acknowledgement of this fault.
F52981: Absolute encoder motor mismatched Message class: General drive fault (19) Reaction: OFF1 Acknowledgement: IMMEDIATELY	Connected absolute encoder motor cannot be operated. The servo drive in use does not support the Motor ID.	Use a suitable absolute encoder motor.
F52983: No encoder detected Message class: General drive fault (19) Reaction: OFF1 Acknowledgement: IMMEDIATELY	The servo drive in use does not support encoderless operation.	<ul style="list-style-type: none"> Check the encoder cable connection between the servo drive and the servo motor. Use a servo motor with encoder.
F52984: Incremental encoder motor not configured Message class: General drive fault (19) Reaction: OFF1 Acknowledgement: IMMEDIATELY	<ul style="list-style-type: none"> Commissioning of the servo motor has failed. The incremental encoder motor is connected but fails to commission. 	Configure the motor ID by setting the parameter p29000.

12.2 List of faults and alarms

Fault	Cause	Remedy
F52985: Absolute encoder motor wrong Message class: General drive fault (19) Reaction: OFF1 Acknowledgement: IMMEDIATELY	<ul style="list-style-type: none"> Motor ID is downloaded wrong during manufacture. The firmware of the servo drive does not support the Motor ID. 	<ul style="list-style-type: none"> Update the firmware. Use a correct absolute encoder motor.
F52987: Absolute encoder replaced Message class: General drive fault (19) Reaction: OFF1 Acknowledgement: IMMEDIATELY	Incorrect absolute encoder data.	Contact the Hotline.

Alarm list

Alarm	Cause	Remedy
A1009: Control module over-temperature Message class: Over-temperature of the electronic components (6)	The temperature of the control module (Control Unit) has exceeded the specified limit value.	<ul style="list-style-type: none"> Check the air intake for the Control Unit. Check the Control Unit fan. Note: The alarm automatically disappears after the limit value has been undershot.
A1019: Writing to the removable data medium unsuccessful Message class: Over-temperature of the electronic component (6)	The write access to the removable data medium was unsuccessful.	Remove and check the removable data medium. Then run the data backup again.
A1032: All parameters must be saved Message class: Hardware/software error (1)	The parameters of an individual drive object were saved, although there is still no backup of all drive system parameters. The saved object-specific parameters are not loaded the next time that the system powers up. For the system to successfully power up, all of the parameters must have been completely backed up.	Save all parameters.
A1045: Configuring data invalid Message class: Hardware/software error (1)	An error was detected when evaluating the parameter files saved in the non-volatile memory. Because of this, under certain circumstances, several of the saved parameter values were not able to be accepted.	Save the parameterization using the "Copy RAM to ROM" function on the BOP. This overwrites the incorrect parameter files in the non-volatile memory – and the alarm is withdrawn.

Alarm	Cause	Remedy
A1902: PROFIdrive: Clock cycle synchronous operation parameterization not permissible Message class: Error in the parameterization/configuration/commissioning procedure (18)	Parameterization for isochronous operation is not permissible.	<ul style="list-style-type: none"> Adapt the bus parameterization Tdp, Ti, To. Adapt the sampling time for the current controller or speed controller. Reduce Tdx by using fewer bus participants or shorter telegrams.
A1920: Drive Bus: Receive setpoints after To Message class: Communication to the higher-level controller faulted (9)	Output data of Drive Bus master (setpoints) received at the incorrect instant in time within the Drive Bus clock cycle.	<ul style="list-style-type: none"> Check bus configuration. Check parameters for clock cycle synchronization (ensure $To > Tdx$). Note: To: Time of setpoint acceptance Tdx: Data exchange time
A1932: Drive Bus clock cycle synchronization missing for DSC Message class: Error in the parameterization/configuration/commissioning procedure (18)	There is no clock synchronization or clock synchronous sign of life and DSC is selected. Note: DSC: Dynamic Servo Control	Set clock synchronization across the bus configuration and transfer clock synchronous sign-of-life.
A1940: PROFIdrive: clock cycle synchronism not reached Message class: Communication to the higher-level controller faulted (9)	The bus is in the data exchange state and clock synchronous operation has been selected using the parameterizing telegram. It was not possible to synchronize to the clock cycle specified by the master. <ul style="list-style-type: none"> The master does not send a clock synchronous global control telegram although clock synchronous operation was selected when configuring the bus. The master is using another clock synchronous DP clock cycle than was transferred to the slave in the parameterizing telegram. At least one drive object has a pulse enable (not controlled from PROFIdrive either). 	<ul style="list-style-type: none"> Check the master application and bus configuration. Check the consistency between the clock cycle input when configuring the slave and clock cycle setting at the master. Check that no drive object has a pulse enable. Only enable the pulses after synchronizing the PROFIdrive.
A1944: PROFIdrive: Sign-of-life synchronism not reached Message class: Communication to the higher-level controller faulted (9)	The bus is in the data exchange state and clock synchronous operation has been selected using the parameterizing telegram. Synchronization with the master sign-of-life (STW2.12...STW2.15) could not be completed because the sign-of-life is changing differently to how it was configured in the Tmapc time grid.	Ensure that the master correctly increments the sign-of-life in the master application clock cycle Tmapc.

12.2 List of faults and alarms

Alarm	Cause	Remedy
<p>A5000: Drive heat sink over-temperature Message class: Power electronics faulted (5)</p>	<p>The alarm threshold for overtemperature at the inverter heat sink has been reached. If the temperature of the heat sink increases by an additional 5 K, then fault F30004 is initiated.</p>	<p>Check the following:</p> <ul style="list-style-type: none"> • Is the surrounding temperature within the defined limit values? • Have the load conditions and the load duty cycle been appropriately dimensioned? • Has the cooling failed?
<p>A6310: Supply voltage (p29006) incorrectly parameterized Message class: Network fault (2)</p>	<p>For AC/AC drive units, the measured DC voltage lies outside the tolerance range after pre-charging has been completed. The following applies for the tolerance range: $1.16 \times p29006 < r0026 < 1.6 \times p29006$ Note: The fault can only be acknowledged when the drive is switched off.</p>	<ul style="list-style-type: none"> • Check the parameterized supply voltage and if required change it (p29006). • Check the line supply voltage. <p>See also: p29006 (Line supply voltage)</p>
<p>A7012: Motor temperature model 1/3 overtemperature Message class: Motor overload (8)</p>	<p>The motor temperature model 1/3 identified that the alarm threshold was exceeded.</p>	<ul style="list-style-type: none"> • Check the motor load and reduce it if required. • Check the motor surrounding temperature.
<p>A7092: Drive: Moment of inertia estimator still not ready Message class: Error in the parameterization/configuration/commissioning procedure (18)</p>	<p>The moment of the inertia estimator has still not determined any valid values. The acceleration cannot be calculated. The moment of inertia estimator has stabilized, if the ratio of machine load moment of inertia (p29022) have been determined.</p>	<p>Traverse the axis until the moment of inertia estimator has stabilized. The alarm is automatically withdrawn after the moment of inertia estimator has stabilized.</p>
<p>A7440: EPOS: Jerk time is limited Message class: Error in the parameterization/configuration/commissioning procedure (18)</p>	<p>The calculation of the jerk time $T_r = \max(p2572, 2573)/2574$ resulted in an excessively high value so that the jerk time is internally limited to 1000 ms. Note: The alarm is also output if jerk limiting is not active.</p>	<ul style="list-style-type: none"> • Increase the jerk limiting (p2574). • Reduce maximum acceleration or maximum deceleration (p2572, p2573). <p>See also: p2572 (EPOS maximum acceleration), p2573 (EPOS maximum deceleration), p2574 (EPOS jerk limiting)</p>
<p>A7441: LR: Save the position offset of the absolute encoder adjustment Message class: Application/technological function faulty (17)</p>	<p>The status of the absolute encoder adjustment has changed. In order to permanently save the determined position offset (p2525), it must be saved in a non-volatile fashion (p0977).</p>	<p>Not necessary. This alarm automatically disappears after the offset has been saved. See also: p2525 (LR encoder adjustment offset)</p>

Alarm	Cause	Remedy
A7454: LR: Position value preprocessing does not have a valid encoder Message class: Error in the parameterization/configuration/commissioning procedure (18)	One of the following problems has occurred with the position actual value preprocessing: <ul style="list-style-type: none"> • An encoder is not assigned for the position actual value preprocessing. • An encoder is assigned, but no encoder data set. • An encoder and an encoder data set have been assigned, however, the encoder data set does not contain any encoder data or invalid data. 	Check the drive data sets, encoder data sets and encoder assignment.
A7455: EPOS: Maximum velocity limited Message class: Error in the parameterization/configuration/commissioning procedure (18)	The maximum velocity (p2571) is too high to correctly calculate the modulo correction. Within the sampling time for positioning, with the maximum velocity, a maximum of the half modulo length must be moved through. p2571 was limited to this value.	Reduce the maximum velocity (p2571).
A7456: EPOS: Setpoint velocity limited Message class: Application/technological function faulty (17)	The actual setpoint velocity is greater than the parameterized maximum velocity (p2571) and is therefore limited.	<ul style="list-style-type: none"> • Check the entered setpoint velocity. • Reduce the velocity override. • Increase the maximum velocity (p2571). • Check the signal source for the externally limited velocity.
A7457: EPOS: Combination of input signals illegal Message class: Application/technological function faulty (17)	An illegal combination of input signals that are simultaneously set was identified. Alarm value (r2124, interpret decimal): 0: Jog 1 and jog 2. 1: Jog 1 or jog 2 and direct setpoint input/MDI. 2: Jog 1 or jog 2 and start referencing. 3: Jog 1 or jog 2 and activate traversing task. 4: Direct setpoint input/MDI and starting referencing. 5: Direct setpoint input/MDI and activate traversing task. 6: Start referencing and activate traversing task.	Check the appropriate input signals and correct.

12.2 List of faults and alarms

Alarm	Cause	Remedy
<p>A7461: EPOS: Reference point not set Message class: Application/technological function faulty (17)</p>	<p>When starting a traversing block/direct setpoint input, a reference point is not set.</p>	<p>Reference the system (search for reference, flying referencing, set reference point).</p>
<p>A7462: EPOS: Selected traversing block number does not exist Message class: Error in the parameterization/configuration/commissioning procedure (18)</p>	<p>A traversing block selected via PROFINET control words POS_STW1.0 to POS_STW1.5 (when telegram 111 is used) or SATZANW.0 to SATZANW.5 (when telegram 7, 9 and 110 are used) was started via PROFINET control word STW1.6 = 0/1 edge "Activate traversing task".</p> <ul style="list-style-type: none"> The selected traversing block exceeds the block number limit, relevant high-order bits should remain low. Refer to Section "Traversing blocks" The started traversing block is suppressed. <p>Alarm value (r2124, interpret decimal): Number of the selected traversing block that is also not available.</p>	<ul style="list-style-type: none"> Correct the traversing program. Select an available traversing block number.
<p>A7463: EPOS: External block change not requested in the traversing block Message class: Application/technological function faulty (17)</p>	<p>For a traversing block with the block change enable CONTINUE_EXTERNAL_ALARM, the external block change was not requested. Alarm value (r2124, interpret decimal): Number of the traversing block.</p>	<p>Resolve the reason as to why the edge is missing at STW1.13.</p>
<p>A7467: EPOS: Traversing block has illegal task parameters Message class: Error in the parameterization/configuration/commissioning procedure (18)</p>	<p>The task parameter in the traversing block contains an illegal value. Alarm value (r2124, interpret decimal): Number of the traversing block with an illegal task parameter.</p>	<p>Correct the task parameter in the traversing block.</p>
<p>A7468: EPOS: Traversing block jump destination does not exist Message class: Error in the parameterization/configuration/commissioning procedure (18)</p>	<p>In a traversing block, a jump was programmed to a non-existent block. Alarm value (r2124, interpret decimal): Number of the traversing block with a jump destination that does not exist.</p>	<ul style="list-style-type: none"> Correct the traversing block. Add the missing traversing block.
<p>A7469: EPOS: Traversing block < target position < software limit switch minus Message class: Error in the parameterization/configuration/commissioning procedure (18)</p>	<p>In the traversing block the specified absolute target position lies outside the range limited by the software limit switch minus.</p>	<ul style="list-style-type: none"> Correct the traversing block. Change software limit switch minus (p2580).

Alarm	Cause	Remedy
A7470: EPOS: Traversing block > target position > software limit switch plus Message class: Error in the parameterization/configuration/commissioning procedure (18)	In the traversing block the specified absolute target position lies outside the range limited by the software limit switch plus.	<ul style="list-style-type: none"> • Correct the traversing block. • Change software limit switch plus (p2581).
A7471: EPOS: Traversing block target position outside the modulo range Message class: Application/technological function faulty (17)	In the traversing block the target position lies outside the modulo range.	<ul style="list-style-type: none"> • In the traversing block, correct the target position. • Change the modulo range (p29246).
A7472: EPOS: Traversing block ABS_POS/ABS_NEG not possible Message class: Application/technological function faulty (17)	In the traversing block the positioning mode ABS_POS or ABS_NEG were parameterized with the modulo correction not activated.	Correct the traversing block.
A7473: EPOS: Beginning of traversing range reached Message class: Application/technological function faulty (17)	When traversing, the axis has moved to the traversing range limit.	Move away in the positive direction.
A7474: EPOS: End of traversing range reached Message class: Application/technological function faulty (17)	When traversing, the axis has moved to the traversing range limit.	Move away in the negative direction.
A7477: EPOS: Target position < software limit switch minus Message class: Error in the parameterization/configuration/commissioning procedure (18)	In the actual traversing operation, the target position is less than the software limit switch minus.	<ul style="list-style-type: none"> • Correct the target position. • Change software limit switch minus (CI: p2580). See also: p2580 (EPOS software limit switch minus), p2582 (EPOS software limit switch activation)
A7478: EPOS: Target position > software limit switch plus Message class: Error in the parameterization/configuration/commissioning procedure (18)	In the actual traversing operation, the target position is greater than the software limit switch plus.	<ul style="list-style-type: none"> • Correct the target position. • Change software limit switch plus (CI: p2581). See also: p2581 (EPOS software limit switch plus), p2582 (EPOS software limit switch activation)
A7479: EPOS: Software limit switch minus reached Message class: Application/technological function faulty (17)	The axis is at the position of the software limit switch minus. An active traversing block was interrupted.	<ul style="list-style-type: none"> • Correct the target position. • Change software limit switch minus (CI: p2580). See also: p2580 (EPOS software limit switch minus), p2582 (EPOS software limit switch activation)

12.2 List of faults and alarms

Alarm	Cause	Remedy
<p>A7480: EPOS: Software limit switch plus reached Message class: Application/technological function faulty (17)</p>	<p>The axis is at the position of the software limit switch plus. An active traversing block was interrupted.</p>	<ul style="list-style-type: none"> • Correct the target position. • Change software limit switch plus (CI: p2581). <p>See also: p2581 (EPOS software limit switch plus), p2582 (EPOS software limit switch activation)</p>
<p>A7483: EPOS: Travel to fixed stop clamping torque not reached Message class: Application/technological function faulty (17)</p>	<p>The fixed stop in the traversing block was reached without the clamping torque/clamping force having been achieved.</p>	<p>Check the torque limits (p1520, p1521).</p>
<p>A7486: EPOS: Intermediate stop missing Message class: Application/technological function faulty (17)</p>	<p>In the modes "traversing blocks" or "direct setpoint input/MDI" at the start of motion, the binector input "no intermediate stop/intermediate stop" did not have a 1 signal.</p>	<p>Connect a 1 signal to the binector input "no intermediate stop/intermediate stop" and restart motion.</p>
<p>A7487: EPOS: Reject traversing task missing Message class: Application/technological function faulty (17)</p>	<p>In the modes "traversing blocks" or "direct setpoint input/MDI" at the start of motion, the binector input "do not reject traversing task/reject traversing task" does not have a 1 signal.</p>	<p>Connect a 1 signal to the binector input "do not reject traversing task/reject traversing task" and restart motion.</p>
<p>A7496: EPOS: Enable not possible Message class: Application/technological function faulty (17)</p>	<p>In the EPOS control mode, no servo on command is sent to the drive via PROFINET.</p>	<p>Send servo on command to the drive via PROFINET.</p>
<p>A7530: Drive: Drive Data Set DDS not present Message class: Error in the parameterization/configuration/commissioning procedure (18)</p>	<p>The selected drive data set is not available. The drive data set was not changed over.</p>	<ul style="list-style-type: none"> • Select the existing drive data set. • Set up additional drive data sets.
<p>A7565: Drive: Encoder error in PROFIdrive encoder interface 1 Message class: Actual position/speed value incorrect or not available (11)</p>	<p>An encoder error was signaled for encoder 1 via the PROFIdrive encoder interface (G1_ZSW.15).</p>	<p>Acknowledge the encoder error using the encoder control word (G1_STW.15 = 1).</p>
<p>A7576: Encoderless operation due to a fault active Message class: Actual position/speed value incorrect or not available (11)</p>	<p>Encoderless operation is active due to a fault.</p>	<ul style="list-style-type: none"> • Remove the cause of a possible encoder fault. • Carry out a POWER ON (power off/on) for all components.
<p>A7582: Position actual value preprocessing error Message class: Actual position/speed value incorrect or not available (11)</p>	<p>An error has occurred during the position actual value preprocessing.</p>	<p>Check the encoder for the position actual value preprocessing.</p>

Alarm	Cause	Remedy
A7805: Power unit overload I²t Message class: Power electronics faulted (5)	Alarm threshold for I ² t overload of the power unit exceeded.	<ul style="list-style-type: none"> Reduce the continuous load. Adapt the load duty cycle. Check the assignment of the rated currents of the motor and motor module.
A7965: Save required Message class: Error in the parameterization/configuration/commissioning procedure (18)	The angular commutation offset was re-defined and has still not been saved. In order to permanently accept the new value, it must be saved in a non-volatile fashion.	This alarm automatically disappears after the data has been saved.
A7971: Angular commutation offset determination activated Message class: Error in the parameterization/configuration/commissioning procedure (18)	The automatic determination of the angular commutation offset (encoder adjustment) is activated. The automatic determination is carried out at the next power-on command.	The alarm automatically disappears after determination.
A7991: Motor data identification activated Message class: Error in the parameterization/configuration/commissioning procedure (18)	The motor data ident. routine is activated. The motor data identification routine is carried out at the next power-on command.	The alarm automatically disappears after the motor data identification routine has been successfully completed. If a POWER ON or a warm restart is performed with motor data identification selected, the motor data identification request will be lost. If motor data identification is required, it will need to be selected again manually following ramp-up.
A8511: PROFIdrive: Receive configuration data invalid Message class: Error in the parameterization/configuration/commissioning procedure (18)	The drive unit did not accept the receive configuration data.	Check the receive configuration data.
A8526: PROFIdrive: No cyclic connection Message class: Communication to the higher-level controller faulted (9)	There is no cyclic connection to the control.	<ul style="list-style-type: none"> Establish the cyclic connection and activate the control with cyclic operation. Check the parameters "Name of Station" and "IP of Station" (r8930, r8931).
A8565: PROFIdrive: Receive configuration data invalid Message class: Error in the parameterization/configuration/commissioning procedure (18)	A consistency error was detected when activating the configuration. Note: Currently set configuration has not been activated.	Check the required interface configuration, correct if necessary.

12.2 List of faults and alarms

Alarm	Cause	Remedy
A30016: Load supply switched off Message class: Network fault (2)	The DC link voltage is too low.	<ul style="list-style-type: none"> Switch on the load supply. Check the line supply if necessary.
A30031: Hardware current limiting in phase U Message class: Power electronics faulted (5)	Hardware current limit for phase U responded. The pulsing in this phase is inhibited for one pulse period. <ul style="list-style-type: none"> Closed-loop control is incorrectly parameterized. Fault in the motor or in the power cables. The power cables exceed the maximum permissible length. Motor load too high. Power unit defective. Note: Alarm A30031 is always output if, for a power unit, the hardware current limiting of phase U, V or W responds.	Check the motor data. As an alternative, run a motor data identification. <ul style="list-style-type: none"> Check the motor circuit configuration (star-delta) Check the motor load. Check the power cable connections. Check the power cables for short-circuit or ground fault. Check the length of the power cables.
A31411: Encoder 1: Absolute encoder signals internal alarms Message class: Actual position/speed value incorrect or not available (11)	The absolute encoder fault word includes alarm bits that have been set.	<ul style="list-style-type: none"> Check the encoder cable connection and make sure the cables are routed in compliance with EMC. Check the motor temperature. Replace the motor/encoder.
A31412: Error bit set in the serial protocol Message class: Actual position/speed value incorrect or not available (11)	The encoder sends a set error bit via the serial protocol.	<ul style="list-style-type: none"> Carry out a POWER ON (power off/on) for all components. Check that the cables are routed in compliance with EMC. Check the plug connections. Replace the encoder.
A52900: Failure during data copying Message class: General drive fault (19)	<ul style="list-style-type: none"> Copying is halted. The micro SD card/SD card was plugged out. The drive is not in the stop state. 	<ul style="list-style-type: none"> Re-plug in the micro SD card/SD card. Make sure the drive is in the stop state.
A52901: Braking resistor reaches alarm threshold Message class: General drive fault (19)	The heat capacity reaches the threshold (p29005) of the braking resistor capacity.	<ul style="list-style-type: none"> Change the external braking resistor. Increase deceleration time.
A52902: Emergency missing Message class: General drive fault (19)	Implement servo on when the emergency input (EMGS) is switched off.	Switch on the emergency input (EMGS) and then implement servo on.

Appendix

A.1 Assembly of cable terminals on the drive side

Power terminal assembly

Drive type		Procedure	Illustration
200 V variant	FSA FSB FSC FSD	Terminal assembly procedure: 1. Remove the outer sheath of the cable. 2. Remove the insulation from the wire. 3. Insert the stripped end into the cable end sleeve. 4. Crimp the cable end sleeve using a crimp tool for end sleeves.	<p>1 120 ± 5 mm, 10 ± 2 mm, 10 ± 2 mm, 120 ± 5 mm</p> <p>2 $a > 11$ mm, $b = 10$ mm</p> <p>3 $c > 1$ mm</p> <p>4 $d = 8$ mm</p>
400 V variant	FSB FSC	Terminal assembly procedure: 1. Remove the outer sheath of the cable. 2. Remove the insulation from the wire. 3. Insert the stripped end into the spade terminal. 4. Crimp the spade terminal using a crimp tool for cable lugs. (Note: Coat any exposed wires with tin.)	<p>1 120 ± 5 mm, 10 ± 2 mm, 10 ± 2 mm, 200 ± 5 mm</p> <p>2 $a = 6$ mm, $b = 10.7$ mm</p> <p>3</p> <p>4</p>

Encoder terminal assembly

The terminal assembly procedures for incremental and absolute encoders are the same.

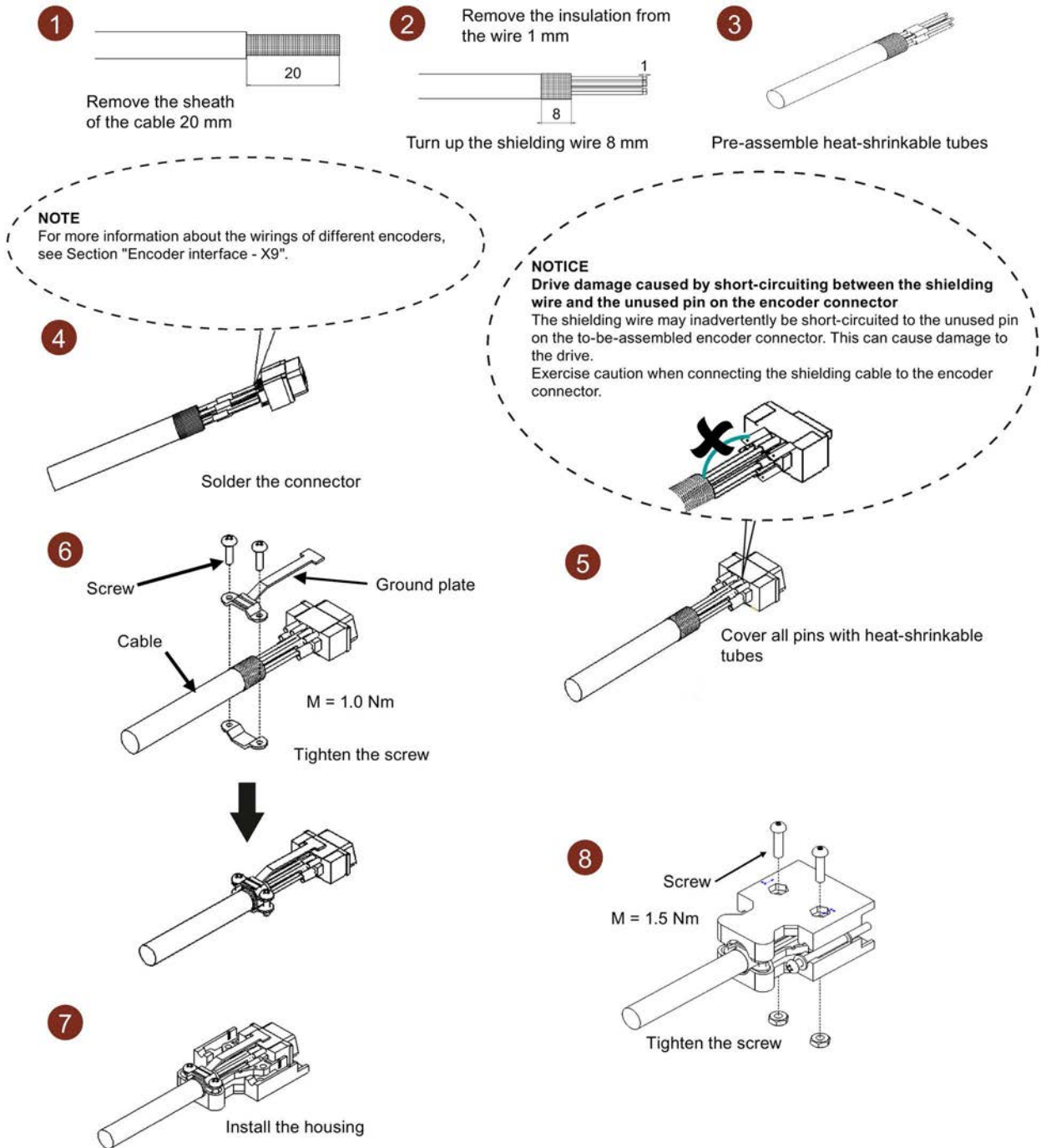

Brake terminal assembly

The assembly of a brake terminal follows the procedure as described in the figure above for a power terminal.

PROFINET I/O connector assembly

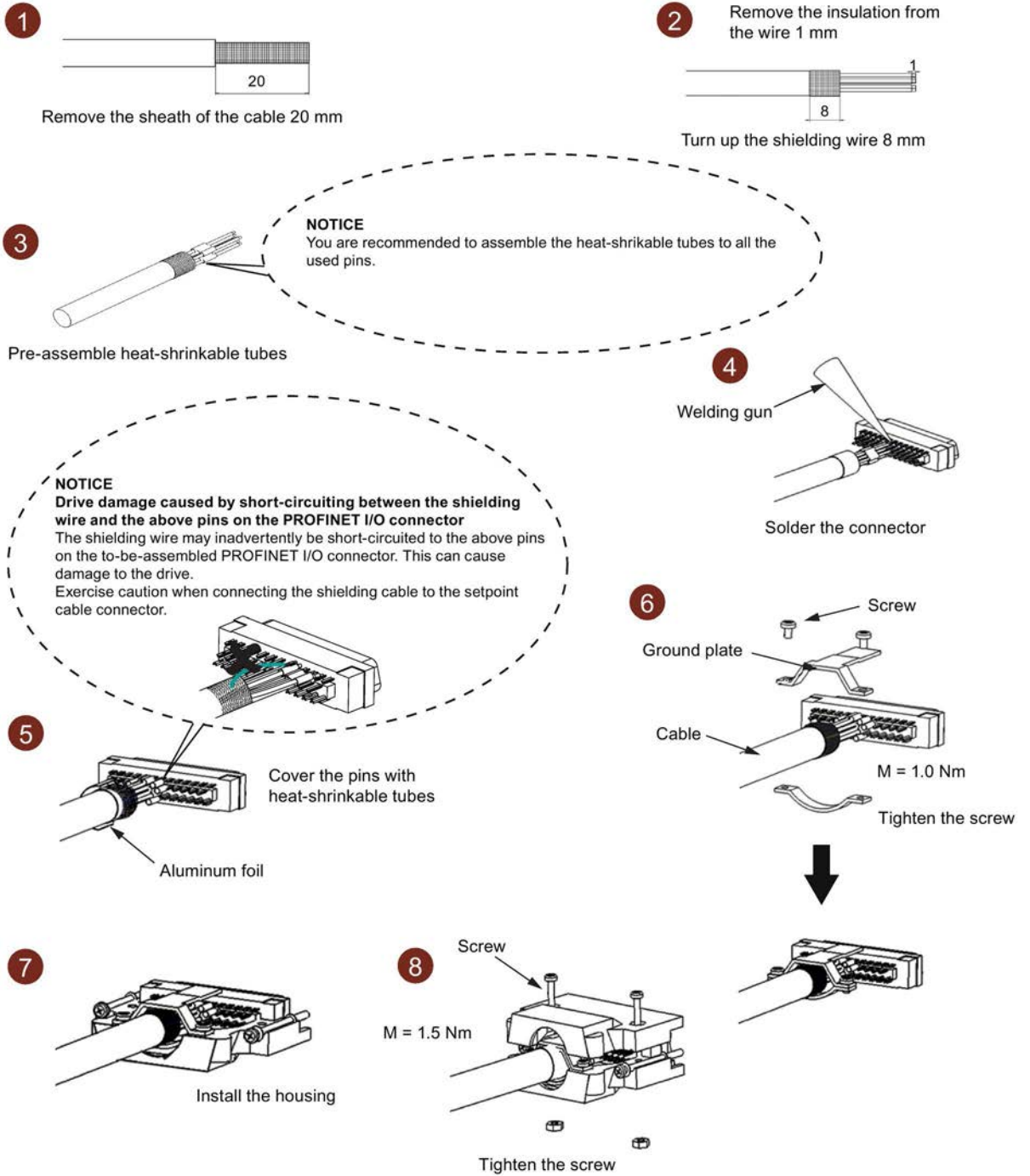

Note

To ensure better EMC effects, you are recommended to strip the PROFINET I/O cable and connect the cable shield to earth.

A.2 Assembly of cable connectors on the motor side

Power connector assembly

Power cable used for low inertia motors with a shaft height of 20 mm to 40 mm

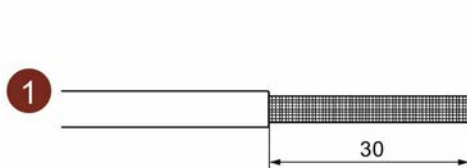

Remove the sheath of the cable 30 mm

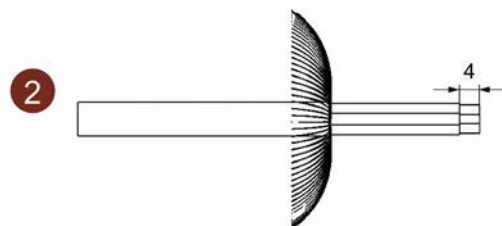

Remove the insulation from the wire 4 mm

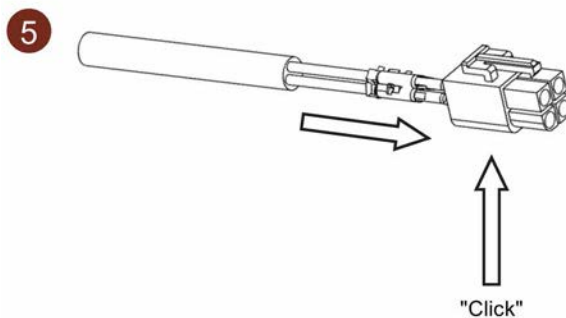
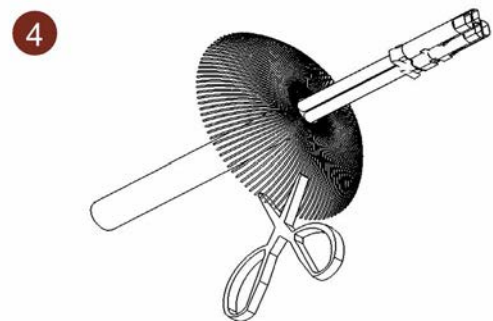
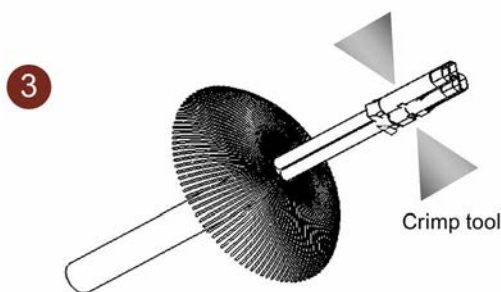

Note

Brake connector assembly

The assembly of the brake connector used for low inertia motors with a shaft height of 20 mm to 40 mm follows the procedure as described in the figure above for a power connector.

Power cable used for motors with straight connectors (low inertia motors with a shaft height of 50 mm and high inertia motors)

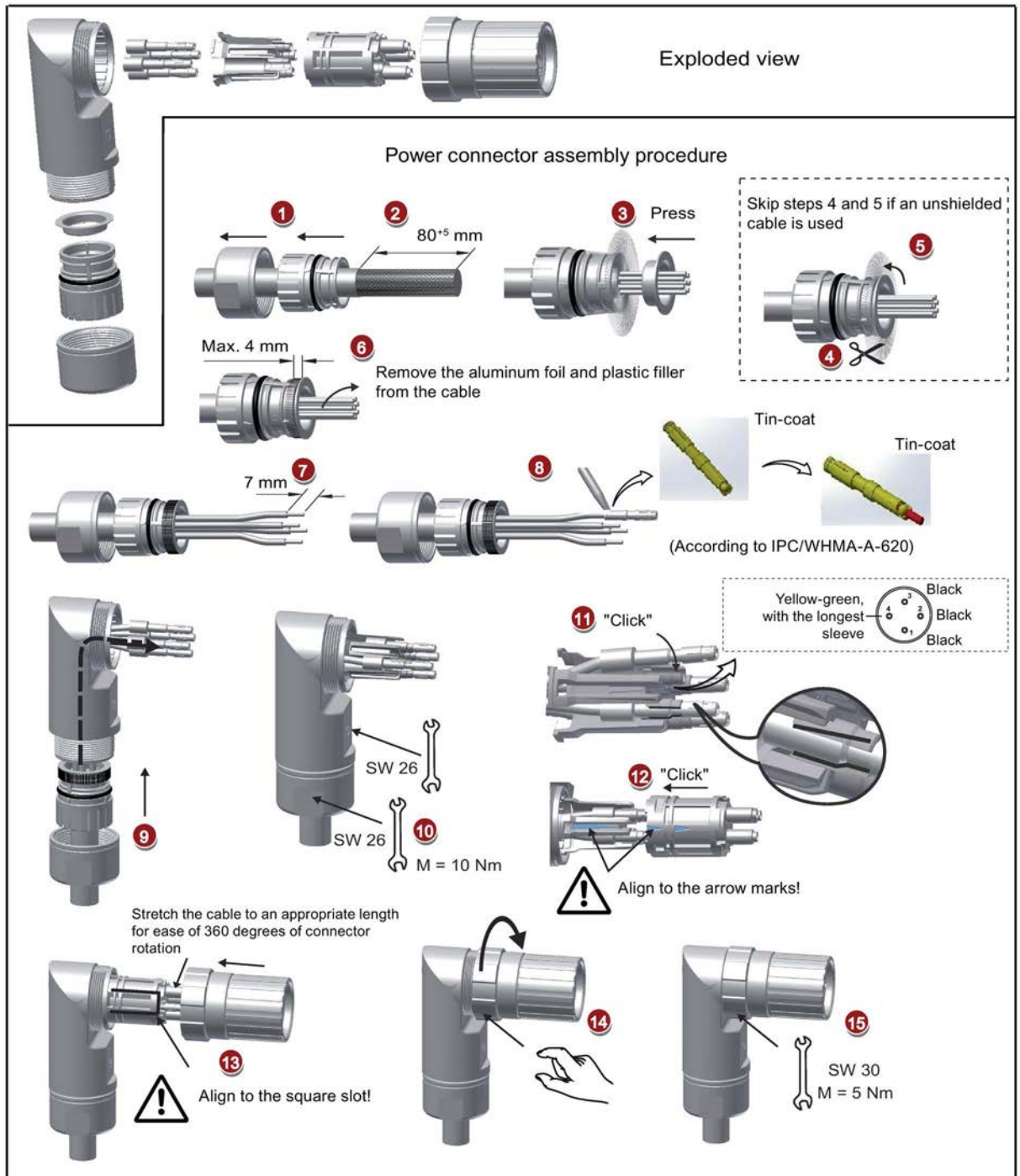

Power cable used for motors with angular connectors (low inertia motors with a shaft height of 50 mm and high inertia motors)

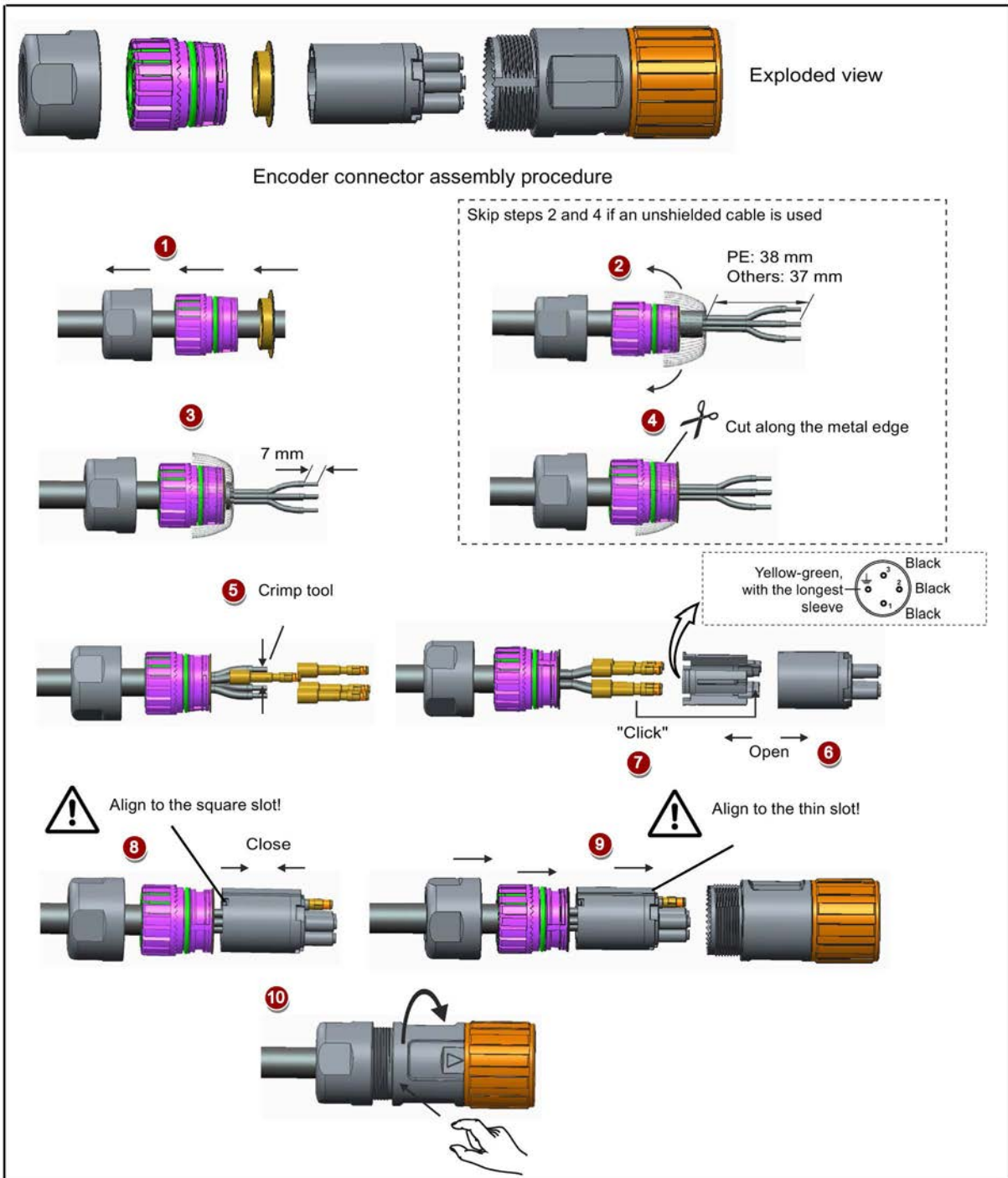

Encoder connector assembly

Incremental encoder cable used for low inertia motors with a shaft height of 20 mm to 40 mm

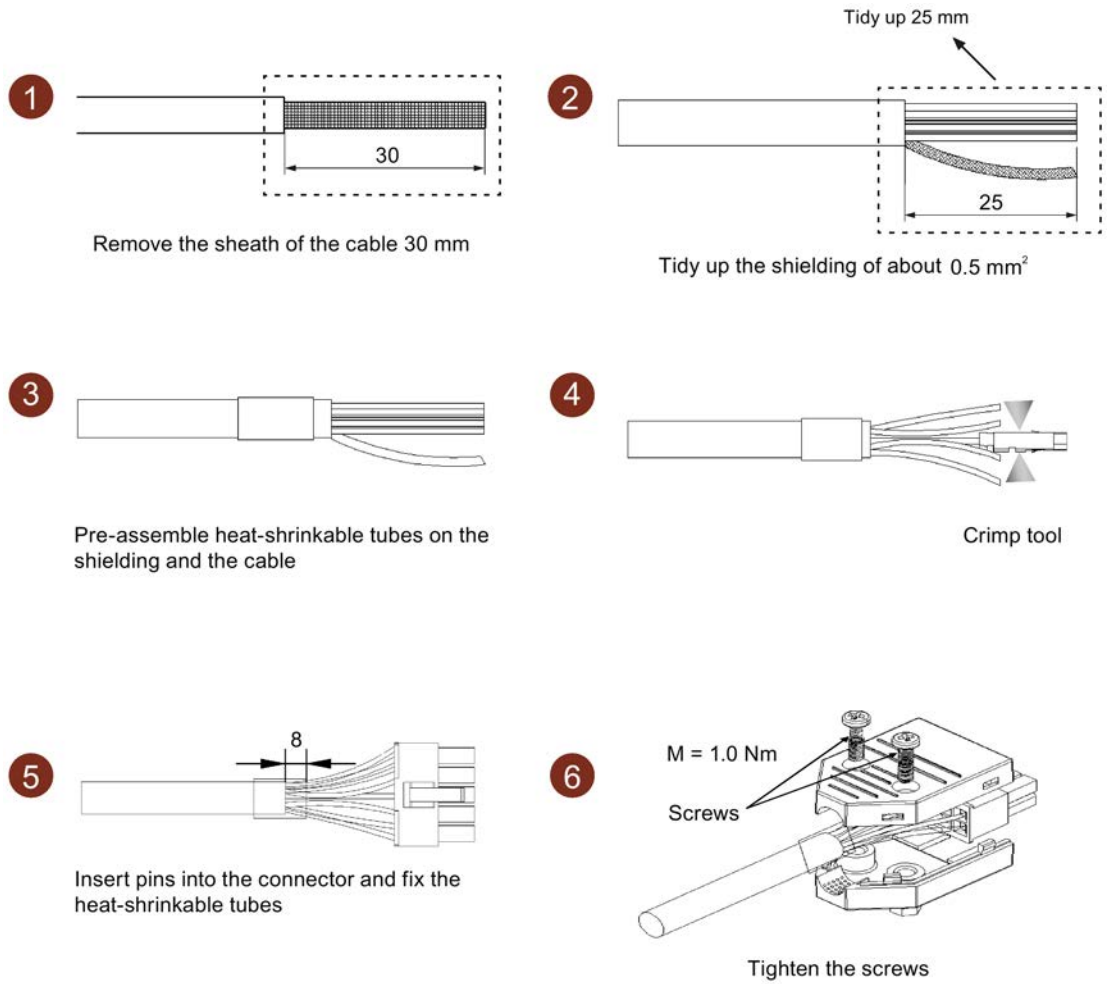

Absolute encoder cable used for low inertia motors with a shaft height of 20 mm to 40 mm

1

Remove the isolation from the wire 5 mm

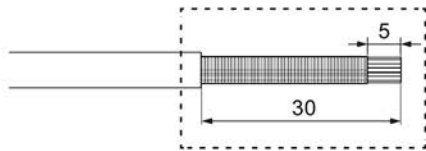

Remove the sheath of the cable 30 mm

2

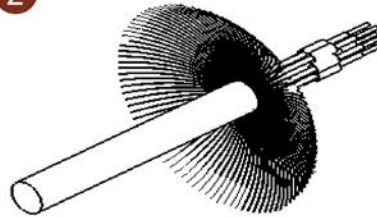

Pre-assembly the heat-shrink tubes

3

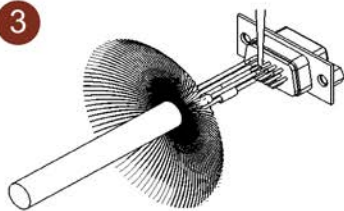

Solder the connector

4

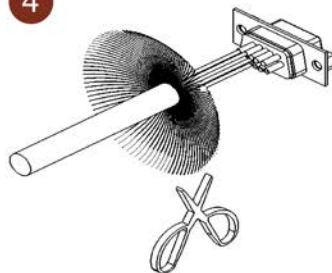

Shield retaining 10 mm

5

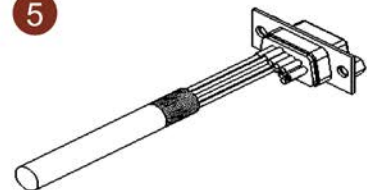

Turn up shielding 10 mm.
Cover all pins with heat-shrinkable tubes

6

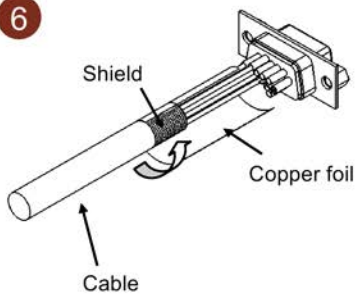

Twine the copper foil on the core wire

7

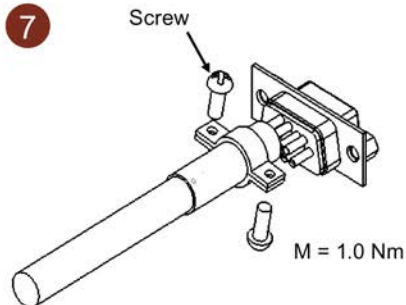

Tighten the screw

8

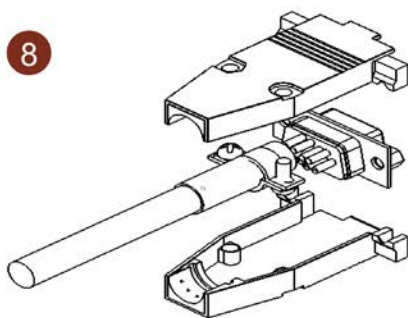

Install housing

9

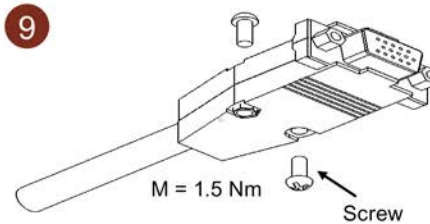

Tighten the screw

Encoder cable used for motors with straight connectors (low inertia motors with a shaft height of 50 mm and high inertia motors)

The connector assembly procedures for absolute and incremental encoders are the same.

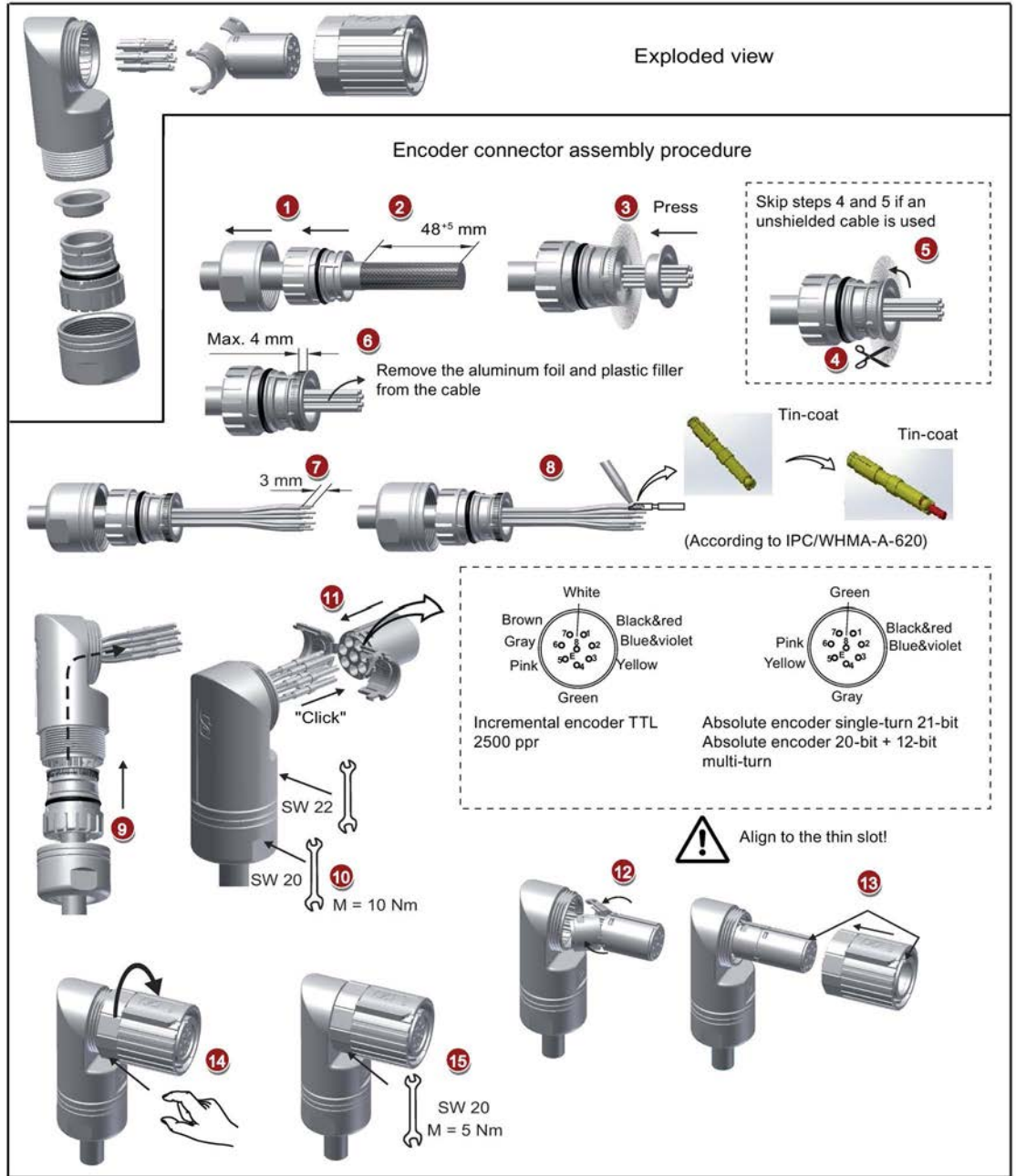

Note

Brake connector assembly for motors with straight connectors

The assembly of the brake connector used for motors with straight connectors (low inertia motors with a shaft height of 50 mm and high inertia motors) follows the procedure as described in the figure above for an encoder connector.

Incremental encoder cable used for motors with angular connectors (low inertia motors with a shaft height of 50 mm and high inertia motors)

For a low inertia motor with a shaft height of 50 mm, the connector assembly procedures for absolute and incremental encoders are the same.

For a high inertia motors with angular connectors, you can assemble the absolute encoder connector with the procedures shown in the figure above.

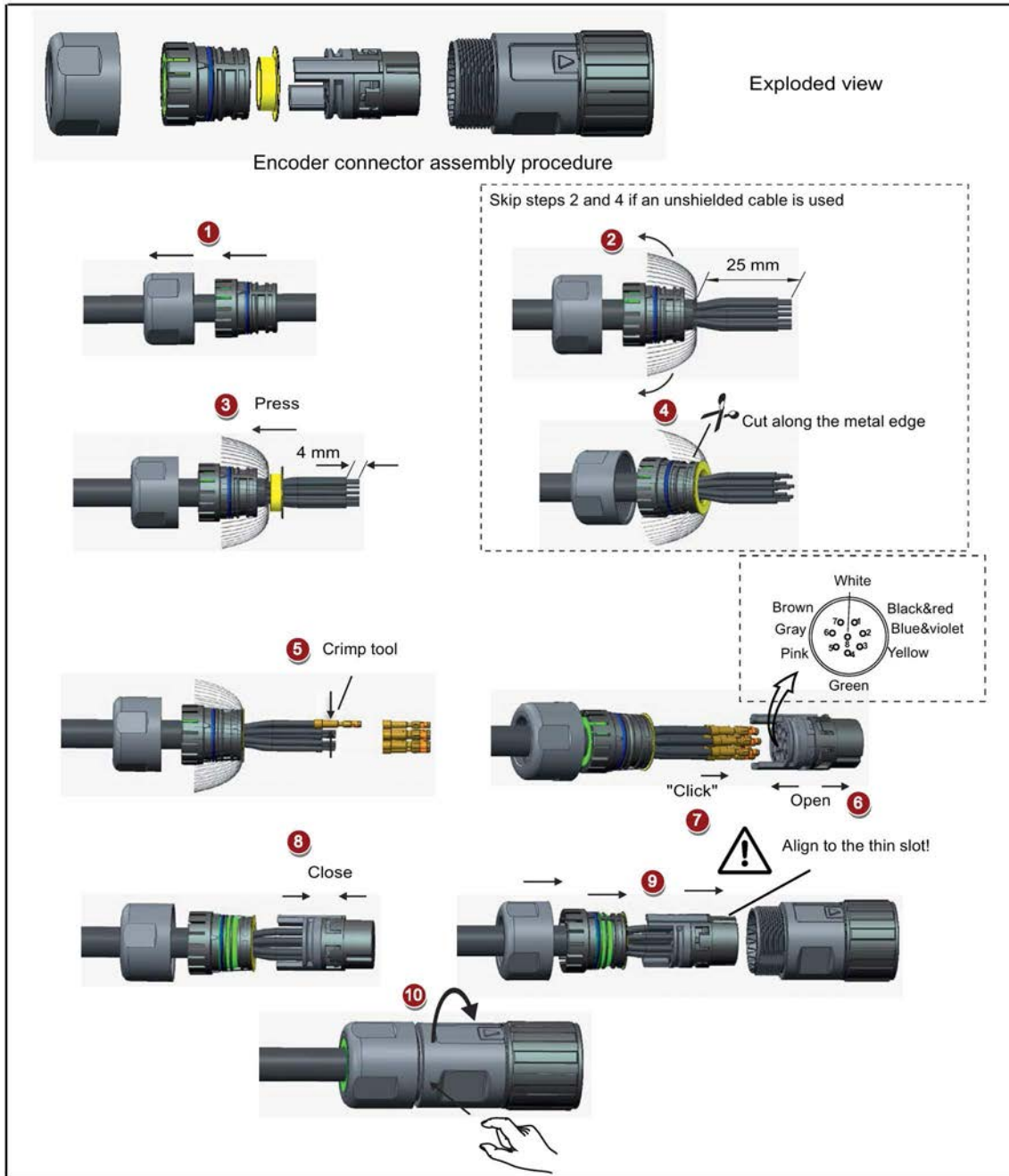

Note

Brake connector assembly for motors with angular connectors

The assembly of the brake connector used for motors with angular connectors (low inertia motor with a shaft height of 50 mm and high inertia motors) follows the procedure as described in the figure above for an incremental encoder connector.

A.3 Motor selection

A.3.1 Selection procedure

1. Determine the mechanism type as well as the detailed data of the related mechanical parts, such as ball screw lead, diameter, lead, and gear diameter. Three mechanism types are shown below:

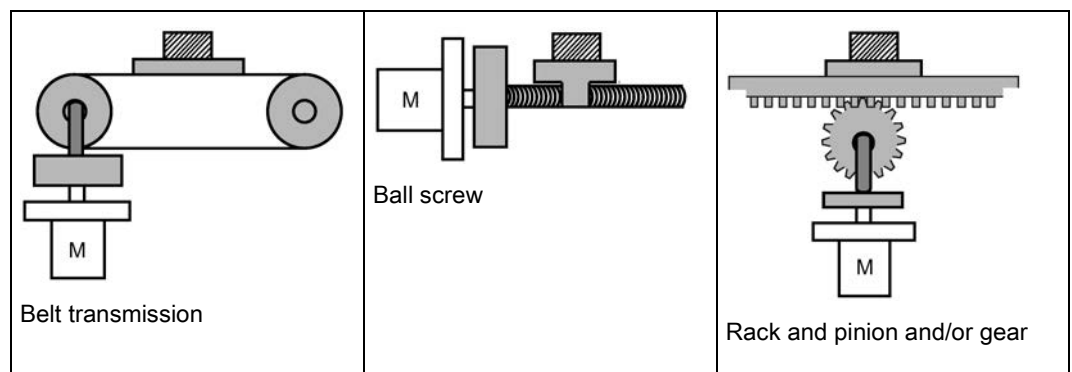

2. Determine the operation pattern including such parameters as acceleration time (t_a), constant motion time (t_u), deceleration time (t_d), stopping time (t_s), cycle time (t_c), and travel distance (L).

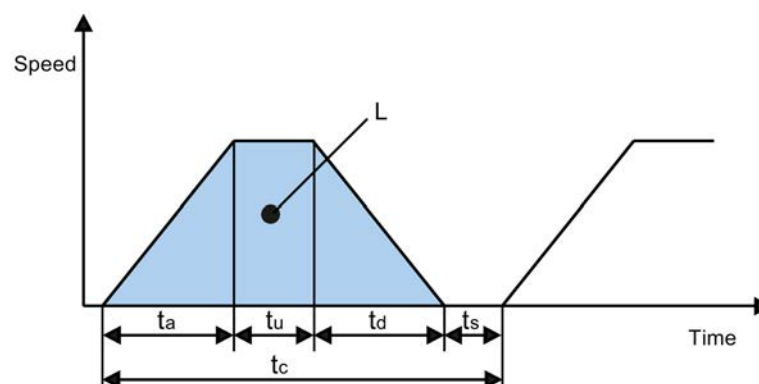

3. Calculate load inertia and inertia ratio.
The inertia ratio can be obtained by dividing the load inertia by the rotor inertia of the selected motor. The unit of inertia is $\times 10^{-4} \text{ kg}\cdot\text{m}^2$.
4. Calculate the speed.
Calculate the speed according to the travel distance, acceleration time, deceleration time, and constant motion time.
5. Calculate the torque.
Calculate the torque according to the load inertia, acceleration time, deceleration time, and constant motion time.
6. Select the motor.
Select the motor that matches the data in step 3 to step 5.

A.3.2 Parameter description

Torque

- Summit torque: It refers to the maximum torque required by a motor in operation, which is generally less than 80% of the motor's maximum torque. When the torque is a negative value, regenerative resistors may be needed.
- Moving torque and hold torque in standstill: It refers to the torque required by a motor in long-term operation, which is generally less than 80% of the motor's rated torque. When the torque is a negative value, regenerative resistors may be needed.
Torque calculation methods of two major mechanism types:

$$T_m = \frac{P_b}{2\pi\eta} (\mu g W + F)$$

W: Mass [kg]

P_b : Ball screw lead [m]

F: External force [N]

η : Mechanical efficiency

μ : Friction coefficient

g: Gravitational acceleration 9.8 [m/s²]

$$T_m = \frac{P_d}{2\eta} (\mu g W + F)$$

W: Mass [kg]

P_d : Belt transmission lead [m]

F: External force [N]

η : Mechanical efficiency

μ : Friction coefficient

g: Gravitational acceleration 9.8 [m/s²]

- Effective torque: It refers to the continuous effective load torque converted into the equivalent value on the servo motor shaft, which is generally less than 80% of the motor's rated torque.

$$T_{rms} = \sqrt{\frac{T_a^2 \times t_a + T_m^2 \times t_u + T_d^2 \times t_d}{t_c}}$$

T_a : Acceleration torque [N·m] t_a : Acceleration time [s] t_c : Cycle time [s]
 T_m : Moving torque [N·m] t_u : Constant motion time [s]
 T_d : Deceleration torque [N·m] t_d : Deceleration time [s]



Speed

Maximum speed: It refers to the motor's maximum speed in operation, which is generally lower than the rated speed. When a motor operating at the maximum speed, pay attention to its torque and temperature rise.

Inertia and inertia ratio

Inertia refers to the force required to keep a certain physical state. Inertia ratio indicates dynamic response performance of motors. The smaller the inertia ratio is the better response performance a motor has.

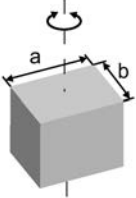
Typical load inertia equations

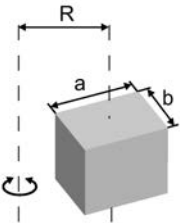
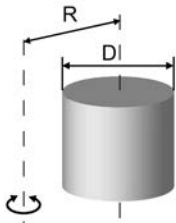
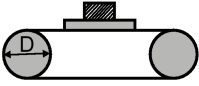
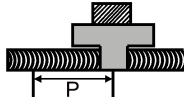
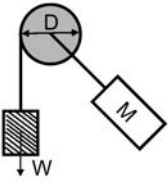
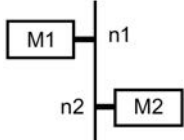
Mechanism	Equation	Mechanism	Equation
 <p>Axis of rotation on center</p>	$J = \frac{W}{12} (a^2 + b^2)$ <p>W: Mass (kg) a: Length (m) b: Width (m)</p>	 <p>Axis of rotation on center</p>	$J = \frac{W}{8} (D_1^2 + D_2^2)$ <p>W: Mass (kg) D₁: External diameter (m) D₂: Internal diameter (m)</p>
 <p>Axis of rotation off center</p>	$J = W \cdot \left(\frac{a^2 + b^2}{3} + R^2 \right)$ <p>W: Mass (kg) a: Length (m) b: Width (m) R: Rotational diameter (m)</p>	 <p>Axis of rotation off center</p>	$J = \frac{W}{8} (D^2 + 8R^2)$ <p>W: Mass (kg) D: Workpiece diameter (m) R: Rotational diameter (m)</p>
 <p>Conveyor</p>	$J = \frac{W \cdot D^2}{4}$ <p>W: Mass (kg) D: Pulley wheel diameter (m)</p>	 <p>Ball screw</p>	$J = \frac{W \cdot P^2}{4\pi^2} + J_b$ <p>W: Mass (kg) P: Lead (m) J_b: Ball screw inertia (kg·m²)</p>
 <p>Object hung with pulley</p>	$J = W \cdot \left(\frac{D}{2} \right)^2 + J_p$ <p>W: Mass (kg) D: Pulley wheel diameter (m) J_p: Pulley inertia (kg·m²)</p>	 <p>Reducer</p>	$J = J_1 \cdot \frac{n_1^2}{n_2^2} \cdot J_2$ <p>W: Mass (kg) n₁/n₂: Speed of each motor (rpm) J₁/J₂: Inertia of each motor (kg·m²)</p>

A.3.3 Selection examples

This section uses a ball screw mechanism as an example to illustrate the motor selection procedure.

Exemplary data

The following table lists the data related to the ball screw mechanism and operation pattern.

Mechanism		Operation pattern	
Workpiece weight (W)	40 kg	Acceleration time (t_a)	0.15 s
Ball screw length (B_l)	2 m	Constant motion time (t_u)	0.7 s
Ball screw diameter (B_d)	0.04 m	Deceleration time (t_d)	0.15 s
Ball screw pitch (B_p)	0.04 m	Cycle time (t_c)	2 s
Mechanical efficiency (B_η)	0.9	Travel distance (L)	0.5 m
Coupler inertia (J_c)	$20 \times 10^{-6} \text{ kg}\cdot\text{m}^2$ (refer to the supplier's product catalog)	-	

1. Ball screw weight

$$B_w = \rho \times \pi \times (B_d/2)^2 \times B_l = 19.85 \text{ kg}$$

2. Load inertia

$$J_l = J_c + J_b = J_c + 1/8 \times B_w \times B_d^2 + W \times B_p^2 / 4\pi^2 = 5.61 \times 10^{-3} \text{ kg}\cdot\text{m}^2$$

3. Preselection

$$\text{If a 1000 W motor is selected, } J_m \text{ (motor inertia) } = 1.57 \times 10^{-3} \text{ kg}\cdot\text{m}^2$$

$$\text{Therefore, } J_l / J_m \text{ (inertia ratio) } = 3.57 < 5 \text{ times}$$

4. Maximum rotational speed

$$V_{\max} \text{ (maximum travelling speed) } = 2L / (t_a + 2t_u + t_d) = 5.89 \text{ m/s}$$

$$N_{\max} \text{ (maximum rotational speed) } = 60 \times V_{\max} / B_p = 882 \text{ rpm} < 2000 \text{ rpm (rated speed)}$$

5. Effective torque

$$T_m \text{ (moving torque) } = (\mu gW + F) \times B_p / 2\pi B_\eta = 0.069 \text{ Nm}$$

$$T_a \text{ (acceleration torque) } = [(J_l + J_m) \times 2\pi N / T_a] + T_m = 4.49 \text{ Nm}$$

$$T_d \text{ (deceleration torque) } = [(J_l + J_m) \times 2\pi N / T_d] - T_m = 4.35 \text{ Nm}$$

$$\text{Therefore, } T_{\text{rms}} \text{ (effective torque) } = \sqrt{(T_a^2 \times t_a + T_m^2 \times t_b + T_d^2 \times t_d) / t_c} = 1.71 \text{ Nm} < 4.78 \text{ Nm (rated torque)}$$

6. Final selection

According to the above calculated speed, torque, and inertia ratio, you are recommended to select 1000 W motors, i.e. 1FL6062.

A.4 Replacing fans

Proceed as illustrated below to remove the fan from the drive. To re-assemble the fan, proceed in reverse order. When re-assembling the fan, make sure that the arrow symbol ("A" in the illustration) on the fan points to the drive rather than the fan housing.

Replacing the fan (example)

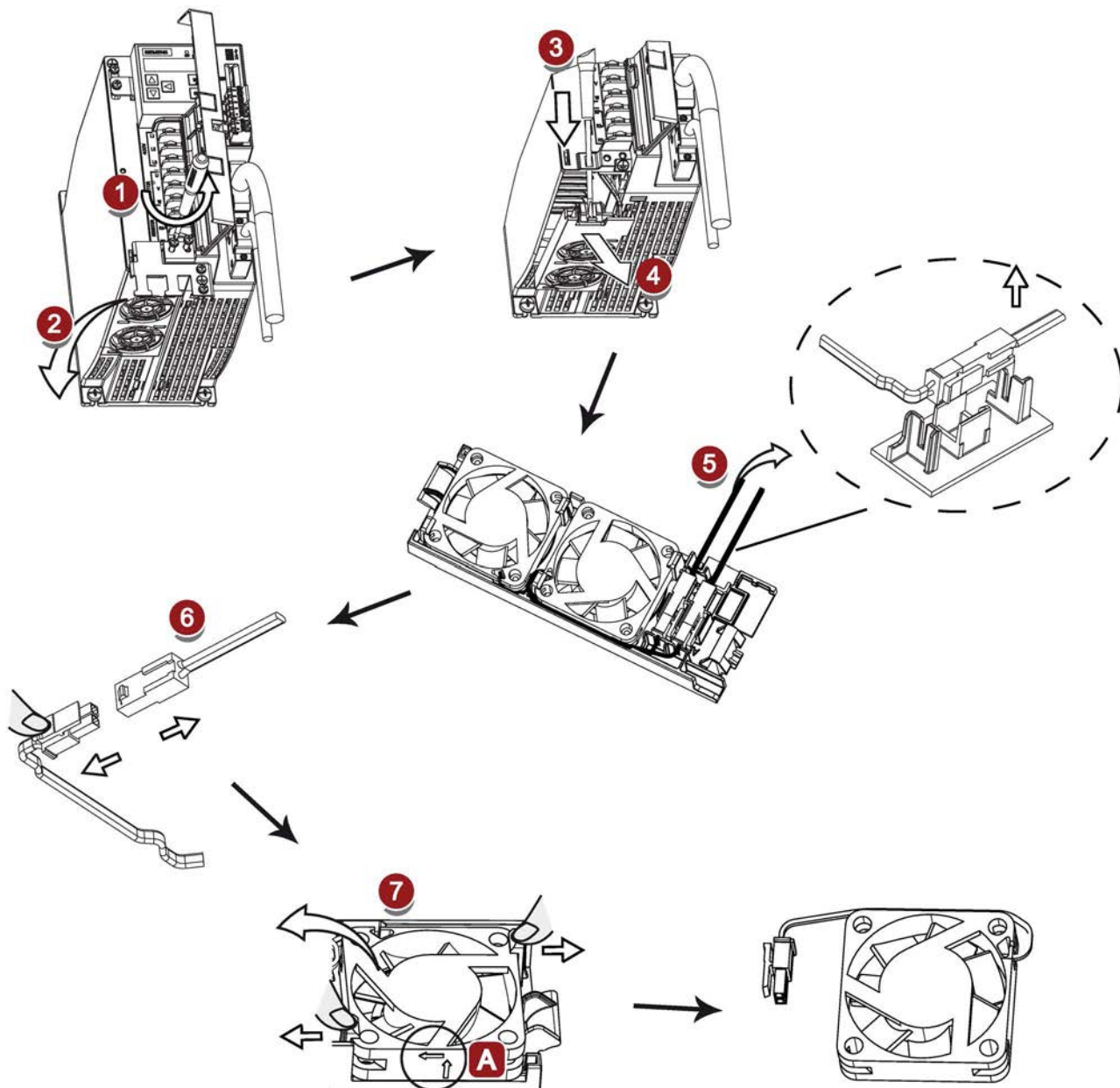

Index

A

- Accessories
 - Braking resistor, 45
 - Filter, 46
 - Fuse/Type-E combination motor controller, 43
 - Micro SD card/SD card, 52
 - MOTION-CONNECT 300 cable and connector, 40
 - Replacement fans, 52
- Aims, 209
- ANSI B11, 220

B

- Backlash compensation, 164
- Basic positioner (EPOS)
 - Linear/modular axis, 163
- BOP operations
 - Button functions, 136
- BOP operations for faults and alarms, 286
 - Acknowledging faults, 287
 - Exiting from alarm display, 286
 - Exiting from fault display, 286
 - Viewing alarms, 286
 - Viewing faults, 286
- BOP overview, 131

C

- Certification, 222
- Change a parameter value, 140
 - Set the parameter value directly, 140
 - Set the parameter value with a shift function, 141
- Commissioning
 - Initial commissioning, 127
- Connecting
 - 24 V power supply/STO, 110
 - Connecting an external braking resistor, 116
- Copy parameter set from a micro SD card/SD card to drive, 147
- Copy parameters from the servo drive to a micro SD card/SD card, 146

D

- Differences between faults and alarms, 285
- Digital inputs, 103
 - Wiring, 104
- Digital outputs, 104
 - Wiring, 105
- DIN EN ISO 13849-1, 213
- Direction of motor rotation, 151

E

- EN 61508, 216
- EN 62061, 214
- EPOS
 - Traversing blocks, 172
- Equipment regulations, 221

F

- Function list, 53
- Functional safety, 210

G

- General information about faults and alarms, 283

H

- Harmonized European Standards, 211

I

- Internal position control mode (IPos)
 - Setting mechanical system, 162
 - Software position limit, 166
- Iterative process for achieving safety, 217

J

- JOG function, 144
 - JOG in speed, 144
 - JOG in torque, 144

L

LED status indicators, 132

M

Machine safety in Japan, 221

Machine safety in the USA, 218

Machinery directive, 210

Main circuit wirings

Connecting the motor power - U, V, W, 99

Motor holding brake, 116

Relevant parameters, 121

Motor rating plate, 30

Motor selection method, 323

Mounting the motor

Motor dimensions, 81

Mounting orientation, 78

N

NFPA 79, 219

NRTL, 219

O

Operating display, 138

OSHA, 218

Over-travel, 165

Overview of SINAMICS V90 PN BOP functions, 143

P

Preface

Documentation components, 3

Target group, 3

Technical support, 3

Probability of failure, 224

R

Referencing

Referencing modes, 167

Residual risk, 218

Resonance suppression, 241

Activate the resonance suppression function, 242

Manual tuning with resonance suppression
(p29021=0), 243

One-button auto tuning with resonance suppression
(p29023.1=1), 242

Real-time auto tuning with resonance suppression
(p29024.6=1), 243

Response time, 225

Risk analysis, 216

Risk reduction, 218

S

Safe Torque Off

Functional features, 226

response time, 228

selecting/deselecting STO, 227

Safety Intefrated function, 222

Safety of machinery in Europe, 210

Save parameters in the servo drive, 145

Search a parameter in "P ALL" menu, 142

Set parameter set to default, 146

Set zero position, 149

Speed control mode

Ramp-function generator, 186

Speed limit, 183

Overall speed limit, 183

Standards for implementing safety-related
controllers, 212

Stopping method

Coase-down (OFF2), 152

Ramp-down (OFF1), 152

Stopping method at servo OFF, 152

Emergency stop, 152

T

Technical data

Cables, 68

Torque control mode

Internal speed limit, 184

Torque limit, 184

Internal torque limit, 185

Overall torque limit, 184

Torque limit reached (TLR), 185

Traversing blocks, 172

Traversing task

Rejecting, 174

Tuning

Configuration of dynamic factor, 234, 238

Manual tuning, 240

Real-time auto tuning, 237

Servo gains, 229

Tuning methods, 231
Tuning with SINAMICS V-ASSISTANT, 232

U

Update firmware, 148
Usage of shielding plate, 94

W

Wiring and connecting
Adjusting cable orientations, 95

